

Application Note: Open Collector Inputs July 2008

Elmo Motion Control Ltd. Copyright © 2008. All rights reserved.

Introduction

Open collector inputs are typically used for purposes of signal indication, alarm and warning notification, control signal input, etc. Although such inputs allow for a great deal of wiring flexibility, care must be taken not to destroy the circuits via incorrect polarity configurations, over-voltage, transients or current overload.

Elmo's Solution

[Elmo Servo driver inputs](#) require a signal voltage of 0 to 5V (WHI only) or 0 to 24V. Therefore, to function properly, open collector input circuits must be complemented with a pull-up resistor.

Elmo digital NPN style inputs are optic isolated from the instrument's power supply. This means that, if required, the input can be used in an NPN configuration as well as in a PNP configuration.

Two sample circuits are included below to present the wiring of the digital output to a programmable logic controller (PLC):

Wiring NPN and PNP Style Outputs to a HAR Digital Input

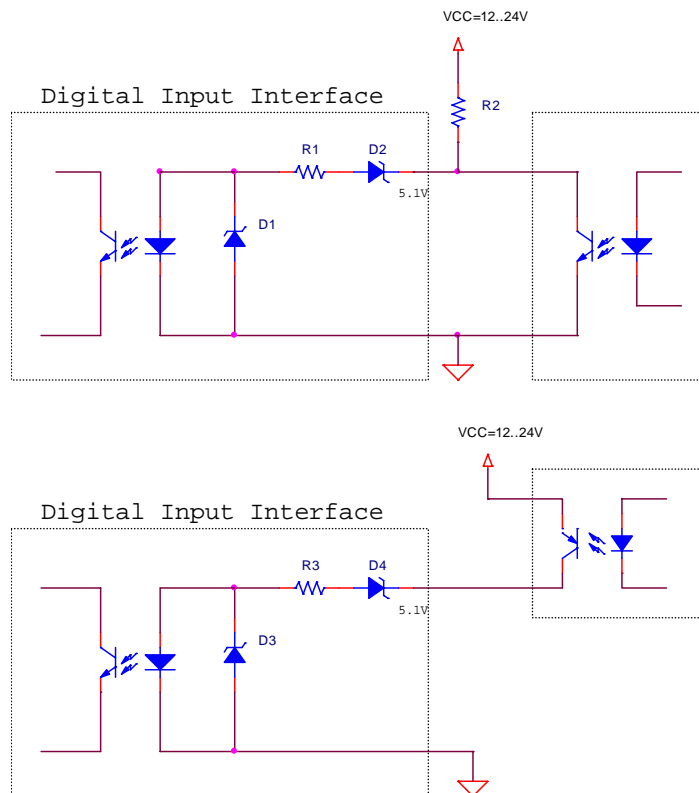

Voltage and Current Limitation

The supply voltage in the optically coupled output circuit MUST be limited to the specified maximum voltage. The use of a quality regulated 5V, 12V or 24V power supply is recommended. In any case, the maximum supply voltage should not exceed 30V DC.

When using the [WHI servo drive](#), the maximum supply voltage should not exceed 10V DC (A typical voltage level of 5V DC). The current through the open collector circuit must also be limited. Typical optically coupled outputs allow only 3 to 20mA switch current. Exceeding this current limit may cause the immediate burn out of the optically coupled output components. Please refer to the following section on how to calculate the load values.

Load and Pull-Up/Down Resistor Considerations

By utilizing Ohm's law, we can determine the safe limits of load resistance. When the optically coupled switch is closed, almost the entire supply voltage is applied to the load. The resulting current through the load and through the optically coupled switch, as well, can be calculated as:

$$I(\text{Current}) = V(\text{Supply Voltage}) / (R(\text{Load Resistance}) + R(\text{Internal Resistance}))$$

Active High and Active Low Setting

Depending on the desired function of the circuit attached to the optically coupled input, it may be necessary to have the optically coupled device output switch turned "on" or "off". By default, Elmo digital outputs are set to operate in the "active low" mode. This means when the user-defined condition for the activation is met, the optically coupled switch is turned "on". If wired as a standard NPN style output, the logic level of the attached control system or programmable logic controller (PLC) input consequently becomes the "low" logic level.

If a high input logic level is required for activation, the change to the input logic level can be accomplished in two ways, by:

- Wiring the optically coupled output in PNP style (as described above), *or*
- Changing the optically coupled input function to "active high", with the IL [N] command in the Elmo Composer.