

Application Solutions Case Study

Unmanned Intelligent Surveillance Robot

Featured Product – **Hornet 5/60R**

Ultra-compact and Intelligent Servo Drive



55 x 15 x 46.5 mm
(2.2" x 0.6" x 1.8")

Rev. 2
Oct. 2010

Elmo
Motion Control
www.elmomc.com

The Requirements: Compact and High Power Servo Drives

*The challenge:
High power
drives in confined
spaces*

Elmo's **Hornet** digital servo drives are very compact, with high power density and on-board intelligence. This case study shows how one of our customers, a leading defense systems supplier, used **Hornet** servo drives for a small and sophisticated surveillance robot application that operates in extreme environments. This case study will interest you if you would like to:

- Get up to 3.2 kW peak power using a matchbox-sized servo drive.
- Place your drive almost anywhere on the machine.
- Minimize development time, resulting in a short time-to-market.

Machine Description

The intelligent surveillance robot is an innovative, unmanned dual axis robot with a wide range of applications. Its most unique feature is the use of acoustics and phonetics to establish enemy presence in military applications. In addition, the robot can be operated by remote control.

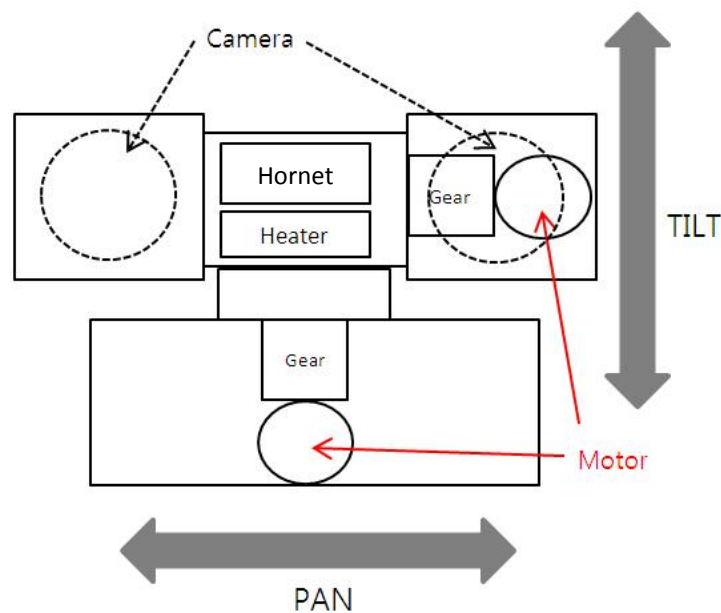

The Hornet servo drives, motor, and all the mechanical components are integrated inside the robot. The robot is required to operate in outdoor scenarios, so its internal heater enables it to cope with extreme environmental conditions. The heater also helps to keep the robot dry.

The surveillance robot is very versatile and can be used in diverse situations, such as urban cityscapes, prisons and border posts. The robot also has military applications, as a weapon can be attached to it.

The robot's dimensions are 83 x 65 x 28 cm.

The surveillance robot must be very small and perform reliably

Application Challenges

The manufacturer's main aims for the surveillance robot were:

- The ability to manage backlash compensation from the ballscrews and gear.
- Dual loop control.
- Lightweight with small dimensions – the robot must be as light and as small as possible.
- Single axis motion control.
- Strong durability even in extreme environments.

When operating in extreme environmental conditions (EEC), the robot's performance must not be compromised. This includes when operating at extreme temperatures (both high and low), and in high humidity.

All the components used in the surveillance robot must be able to withstand mechanical shock and continue functioning in challenging and unpredictable conditions.

The surveillance robot needs to be highly reliable with an extended MTBF (Mean Time Between Failures) for its various motion functions.

As the product incorporates a 360° turning base, the commands must be delivered swiftly and accurately to provide precise motion through slip-ring functionality.

The compact size of the robot demands motion control products that can supply high power-density within a confined space.

Elmo's Solution

A matchbox-sized, PCB-mountable drive that can provide up to 3.2 kW of power

The **Hornet** digital servo drive was chosen for this application, due to its compact size and light weight. It is PCB-mounted and can therefore be integrated into the robot.

The **Hornet** is very compact, measuring just 55 x 15 x 46.5 mm and weighing only 50 g. It has a peak output of 3.2 kW: 30 A at 100 V.

Two HOR-5/60R drives were chosen for installation into the surveillance robot.



Hornet Intelligent Digital Servo Drive

The **Hornet** is a member of Elmo's ExtriQ Line, designed especially for rugged and extreme conditions. This allows the drive to operate in the following extended environments:

- Ambient temperature: -40 °C to +70 °C
- Storage temperature: -50 °C to +100 °C
- Maximum humidity: 90% non-condensing
- Position sampling rate: up to 3.5 kHz
- Maximum operating altitude: 155,000 m
- PWM switching frequency: 22 kHz
- Switching method: Advanced Unipolar PWM

The two **Hornets** are installed on a single PCB within the compact confines of the robot and require minimal cabling. The connector types and locations were chosen to optimize the robot's performance and minimize maintenance. Elmo's engineers worked with the design team in order to ensure that the products were successfully integrated, thereby shortening the time-to-market.

Elmo supplies detailed documentation and consulting services for product integration on the PCB. This enables the best possible fit for the application.

The **Hornet** drives already include the capability to perform sophisticated motion control loops for precise movement, feedback inputs, programming capabilities and communication support. Its excellent connectivity eliminates the need for extra components.

Our experienced engineers will help you get it right the first time.

The **Hornet** drives are very reliable and meet the demands of challenging environments.

Elmo's proprietary Studio software is used to program the commands for the **Hornet** and this enables the robot to perform the precise tasks that require rapid and accurate movement.

Elmo's Interlude for the Robot

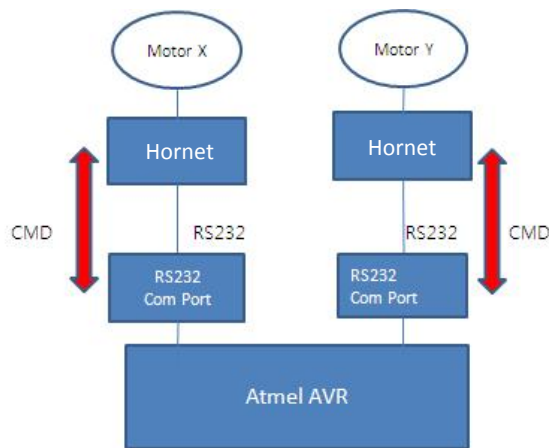

JOG

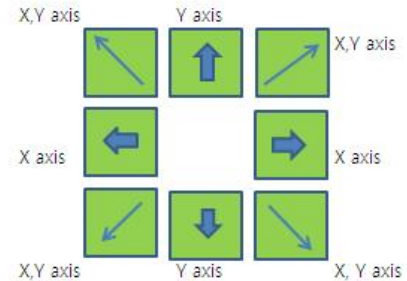

Interlude is an API that is offered to integrators – it supports Visual C++ (ver. 6 and ver. 8) – and it enables Elmo's drives to connect to the Visual C++ Graphical User Interface.

The robot operates on a dual axis where x and y are for pan and tilt respectively. It receives commands from a micro-controller via the RS-232 protocol, or CAN DS-301, which is Elmo's binary interpreter. Diagonal motion requires some modifications to Interlude, as well as two independent drive connect dialogs in order to move two separate controllers. The motion is not synchronized exactly, but it is a simple and versatile solution that can be implemented using user-friendly software.

```

void CClient01View::OnButtonSend02()
{
    UpdateData();
    if(n_sEdit.IsEmpty()) return;

    CString str;
    GetDocument()->n_pDriver[1]->SetErrorCallback(CallBackError);
    if(GetDocument()->SendCommand(n_sEdit, str))
    {
        if(str.IsEmpty()) str = n_sEdit;
        n_ListBox.SetTopIndex(n_ListBox.AddString(str));
        CEdit *pEdit = static_cast<CEdit*>(GetDlgItem(IDC_EDIT));
        pEdit->SetText(0, -1);
        pEdit->SetFocus();
    }
    GetDocument()->n_pDriver[0]->SetErrorCallback(NULL);
}

void CClient01View::OnButtonSend02()
{
    UpdateData();
    if(n_sEdit.IsEmpty()) return;

    CString str;
    GetDocument()->n_pDriver[1]->SetErrorCallback(CallBackError);
    if(GetDocument()->SendCommand(n_sEdit, str))
    {
        if(str.IsEmpty()) str = n_sEdit;
        n_ListBox.SetTopIndex(n_ListBox.AddString(str));
        CEdit *pEdit = static_cast<CEdit*>(GetDlgItem(IDC_EDIT));
        pEdit->SetText(0, -1);
        pEdit->SetFocus();
    }
    GetDocument()->n_pDriver[1]->SetErrorCallback(NULL);
}

```

Dual Loop Control

The robot requires backlash compensation due to camera surveillance over long distances (more than 5 km). Elmo's Dual Loop Control is the most robust and reliable solution and it is straightforward to implement.

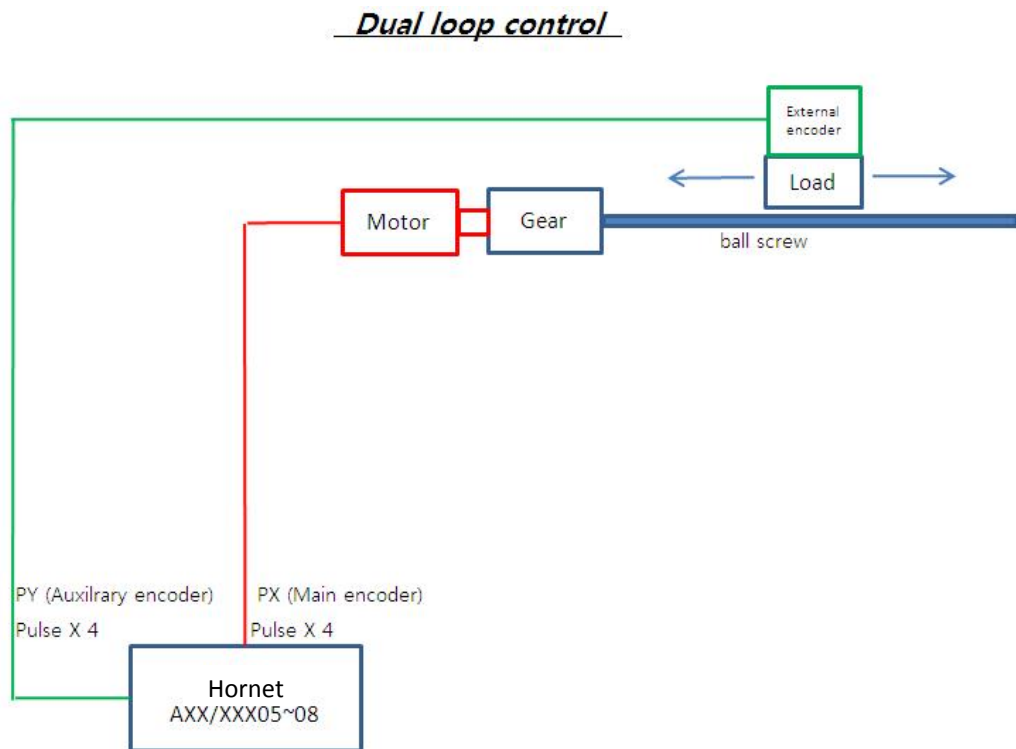

The **Hornet** servo drives provide auxiliary feedback ports for Dual Loop Control as well as Pulse and Direction. Auxiliary feedback ports support the same resolution level as the main feedback ports (multiplied by 4). The external encoder that is mounted outside the robot provides almost zero backlash.

Why Elmo

- Compact, pin-based, PCB-mounted products that have a small footprint.
- High power-density and intelligence within a small package.
- Dedication of the support engineers to the successful implementation of solutions.
- Fast, precise and smooth motion control.
- High reliability in demanding military environments.
- Standard communication protocols (RS-232 and CAN).

For more information on Elmo:

<p>Elmo Motion Control Ltd. 64 Gisin St., P.O. Box 463 Petach Tikva 49103 Israel</p> <p>Tel: +972 (3) 929-2300 Fax: +972 (3) 929-2322 info-il@elmomc.com</p>	<p>Elmo Motion Control Inc. 42 Technology Way, Nashua NH 03060 USA</p> <p>Tel: +1 (603) 821-9979 Fax: +1 (603) 821-9943 info-us@elmomc.com</p>	<p>Elmo Motion Control GmbH Steinkirchring 1 D-78056, Villingen-Schwenningen Germany</p> <p>Tel: +49 (0) 7720-85 77 60 Fax: +49 (0) 7720-85 77 70 info-de@elmomc.com</p>	<p>Elmo Motion Control APAC #807, Kofomo Tower, 16-3 Sunae-dong, Bundang-gu, Seongnam-si, Gyeonggi-do South Korea</p> <p>Tel: [82]-31-698-2010 Fax: [82]-31-698-2013 info-asia@elmomc.com</p>
---	---	---	--

www.elmomc.com