

IBP SERIES OPERATING MANUAL

Rev 6/93

ELMO-WARRANTY PERFORMANCE

The warranty performance covers only Elmo's products and only the elimination of problems that are due to manufacturing defects resulting in impaired function, deficient workmanship or defective material. Specifically excluded from warranty is the elimination of problems which are caused by abuse, damage, neglect, overloading, wrong operation, unauthorized manipulations etc.

The following maximum warranty period applies:

| |
|--|
| 12 months from the time of operational startup but not later than 18 months from shipment by the manufacturing plant. |
|--|

Units repaired under warranty have to be treated as an entity. A breakdown of the repair procedure (for instance of the repair of a unit into repair of cards) is not permissible.

Damage claims, including consequential damages, which exceed the warranty obligation will be rejected in all cases.

If any term or condition in this warranty performance shall be at variance or inconsistent with any provision or condition (whether special or general) contained or referred to in the Terms and Conditions of Sales set out at the back of Elmo's Standard Acknowledge Form, than the later shall prevail and be effective.

How to use this manual - Flow Chart

The IBP amplifier represents a flexible design approach which enables the use of various feedback sensors and allows several modes of operation.

Use the following flow chart in order to determine the chapters that you should read. If you are a new user of the IBP, you should read chapters 1-4 which will familiarize you with the product.

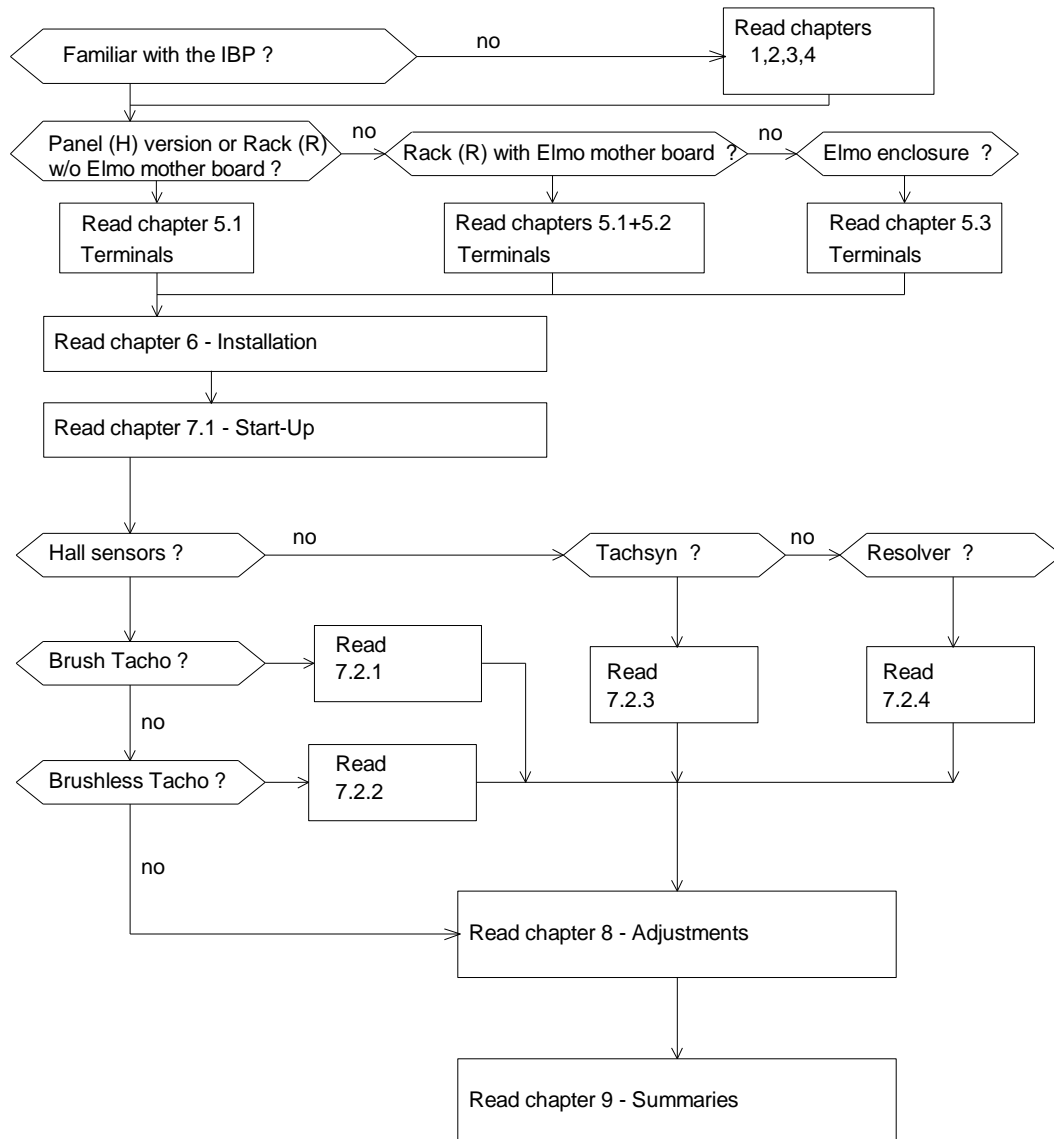

TABLE OF CONTENTS

| | |
|--|----|
| 1. Description | 7 |
| 2. Type Designation | 8 |
| 3. Technical Specifications | 9 |
| 4. Operation of the servo control | 11 |
| 4.1 Inputs..... | 11 |
| 4.2 Velocity mode..... | 12 |
| 4.3 Velocity feedback sensors..... | 13 |
| 4.4 Current mode..... | 13 |
| 4.5 Current feedback..... | 13 |
| Current feedback multiplier (CFM)..... | 13 |
| Current loop..... | 13 |
| 4.6 Current limits..... | 15 |
| 4.6.1 Time dependent peak current limit | 15 |
| 4.6.2 Dynamic contouring of continuous and peak current limits. | 16 |
| 4.7 Operation of the shunt regulator..... | 17 |
| 4.8 Commutation signals format..... | 18 |
| 4.9 Protective functions..... | 19 |
| 4.9.1 Short circuit protection..... | 19 |
| 4.9.2 Under/over voltage protection..... | 19 |
| 4.9.3 Temperature protection..... | 19 |
| 4.9.4 Insufficient load inductance..... | 19 |
| 4.9.5 Loss of velocity feedback signal..... | 19 |
| 4.9.6 Internal power supply failure..... | 19 |
| 4.9.7 Loss of commutation feedback..... | 19 |
| 5. Terminal Description | 23 |
| 5.1 Terminals for Horizontal and Rack mounting versions | 23 |
| 5.2 Mother Boards terminals..... | 31 |
| 5.2.1 MBA-IBP/3UB..... | 31 |
| 5.2.2 MBA-IBP/3UB1..... | 32 |
| 5.2.3 MBA-IBP/3UR..... | 33 |
| 5.2.4 MBA-IBP/3UR1..... | 33 |
| 5.2.5 MBA-IBP/6UB..... | 36 |
| 5.2.6 MBA-IBP/6UR..... | 38 |

| | | |
|-------|--|----|
| 5.3 | Terminals for IBP mounted in ENC. | 40 |
| 5.3.1 | Power connector 3U size - J6 | 40 |
| 5.3.2 | Power connector 6U size - J6 | 40 |
| 5.3.3 | Signal connectors - Brushless Tacho, Tachsyn | 41 |
| 5.3.4 | Signals connectors - Resolver version | 43 |
| 6. | Installation procedures | 51 |
| 6.1 | Mounting | 51 |
| 6.2 | Wiring | 51 |
| 6.3 | Load inductance | 52 |
| 6.4 | AC power supply | 52 |
| 6.5 | Wiring diagrams | 53 |
| 7. | Start - Up Procedures | 66 |
| 7.1 | Common procedures for all amplifiers types | 66 |
| 7.1.1 | Commutation signals format | 66 |
| 7.1.2 | CFM function | 66 |
| 7.1.3 | Inhibit and CW/CCW logic | 66 |
| 7.1.4 | Current mode | 70 |
| 7.1.5 | Velocity mode | 70 |
| 7.1.6 | Selecting the reference signal gain | 71 |
| 7.1.7 | Activating the tacho loss protection (velocity mode only) | 71 |
| 7.1.8 | Latch mode of the protective functions | 72 |
| 7.1.9 | Dynamic contouring of the current limits | 73 |
| 7.2 | Connecting the feedback elements | 73 |
| 7.2.1 | Brush Tachogenerator | 73 |
| 7.2.2 | Brushless Tachogenerator | 74 |
| 7.2.3 | Tachsyn | 75 |
| 7.2.4 | Resolver | 76 |
| 8. | Amplifier adjustment | 84 |
| 8.1 | Current limit adjustment | 84 |
| 8.2 | Balance adjustment | 85 |
| 8.3 | Current gain adjustment (for current mode only) | 86 |
| 8.4 | Adjusting the motor speed (velocity mode only) | 86 |
| 8.5 | Response adjustment (velocity mode only) | 86 |
| 9. | Tables and Summaries | 89 |
| 9.1 | Adjusting trimmers | 89 |

| | |
|--|-----|
| 9.2 LED diagnostics | 89 |
| 9.3 Summary of DIP switches | 90 |
| Appendix A - Current gain and response | 92 |
| Appendix B - Current limits contour adjustment | 94 |
| Appendix C - Differential amplifier connection | 96 |
| DIMENSIONAL DRAWINGS | 97 |
| PANEL (H), BP1 | 98 |
| PANEL (H), BP2 | 101 |
| PANEL (H), BP3 | 104 |
| PANEL (H), BP4 | 107 |
| PANEL (H), BP6 | 110 |
| RACK 3U/12T | 113 |
| RACK 3U/19T | 116 |
| RACK 6U/13T | 119 |
| RACK 6U/20T | 122 |
| ENC- 3U/ | 124 |
| ENC - 6U/ | 125 |
| EXTERNAL SHUNT RESISTOR | 126 |
| List of ELMO Service Centers | 127 |

1. Description

The IBP is a very compact servo package for three phase brushless servo motors in the range of 7KW continuous and 14KW peak. It utilizes power MOSFETs and Surface Mount Technology which contribute to its high efficiency and compact design. The amplifier is ideal for incremental motion control, velocity, and positioning systems which require fast response, smooth speed control and precise position control.

The IBP has a very flexible design. It operates from a single AC supply (either single or three phase) and, when using the galvanic isolation option, it can be connected directly to the Mains. All the common feedback sensors (Hall effect sensors, Brushless Tacho, Tachsyn and Resolver) can be processed by different versions of the IBP.

The IBP is available in either panel mount version, or rack mount version with two 32 pole DIN 41612 connectors. The rack version can be fitted in a panel mount enclosure (ENC-3U or ENC-6U), that is specially designed for a simple hook-up procedure.

The amplifiers are fully protected against the following faults:

- * Under/over voltage
- * Shorts between the outputs, between the outputs to ground or outputs to power supply (+Vs).
- * RMS current limit.
- * Insufficient load inductance.
- * Loss of speed feedback signal.
- * Excess temperature.
- * Loss of commutation signals
- * Internal power supplies failure.

Standard Features:

- * Single AC supply (single or three phase)
- * Zero Deadband.
- * Excellent linearity
- * 3 inputs: gain adjustment.
- * Motor current monitor.
- * Motor speed monitor.
- * Velocity sensor: Brush or Brushless Tachogenerator, Resolver, Tachsyn.

- * Extra differential operational amplifier.
- * Operation in velocity or current mode.
- * Remote voltage/current mode selection.
- * Remote control functions:
Inhibit and CW/CCW disable
- * Adjustable compensation.
- * Adjustable continuous and peak current limits.
- * External current limit input.
- * Dynamic contouring of continuous and peak current limits.
- * Input balance (offset) adjustment.
- * LED diagnostics.
- * Standard commutation sensors: Hall effect, Resolver or Tachsyn.
- * Galvanic isolation of the control stage - optional.
- * Output for external shunt resistor (6U only).

2. Type Designation

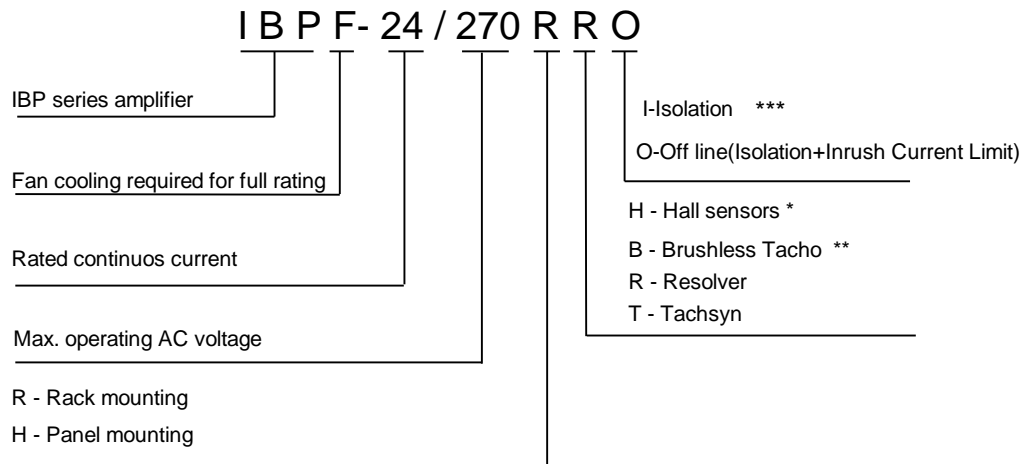

- * The H version accepts a brush tachogenerator for velocity feedback and Hall effect sensors for commutation.
- ** The B version requires Hall effect sensors for commutation.
- *** 3U size is not available with I option (no option or O option only).

3. Technical Specifications

| Type | AC Supply* | | Current limits | Size Panel | Size Rack | Weight (Kg) |
|-------------|------------|-----|-------------------|---------------|--------------|----------------|
| | min | max | | | | |
| IBP-12/135 | 28- | 135 | 12/24 | BP2 | 3U/19T | 1.4 |
| IBP-20/135 | 28- | 135 | 20/40 | BP3 | 6U/20T | 3 |
| IBP- 8/270 | 100- | 270 | 8/16 | BP2 | 3U/19T | 1.4 |
| IBP-16/270 | 100- | 270 | 16/32 | BP3 | 6U/20T | 3 |
| IBPF-12/135 | 28- | 135 | 12/24 | BP1 | 3U/12T | 0.7 |
| IBPF-20/135 | 28- | 135 | 20/40 | BP4 | 6U/13T | 1.3 |
| IBPF-30/135 | 28- | 135 | 30/60 | BP6 | 6U/20T | 3 |
| IBPF- 8/270 | 100- | 270 | 8/16 | BP1 | 3U/12T | 0.7 |
| IBPF-16/270 | 100- | 270 | 16/32 | BP4 | 6U/13T | 1.3 |
| IBPF-24/270 | 100- | 270 | 24/48 | BP6 | 6U/20T | 3 |

* DC output voltage is 130% of AC input voltage.

* 20KHz switching frequency.

* 2KHz current loop response (minimum)

* Outputs voltages of +5V, +15V for external use.

* Efficiency at rated current - 97%.

* Drift: 10 μ V/°C (referred to input)

* Operating temperature: 0-50°C.

* Storage temperature: -10 - +70°C.

* **Fuses: The IBP/6U has fuse on each AC line.**

There are no fuses in the IBP/3U. The unit has to be fused externally.

Resolver Option Features:

* 10,12,14 and 16 bit resolution, set by the user.

* Maximum tracking rate 1014 rps (10 bits).

* Velocity output.

* Encoder A, -A, B, -B outputs + programmable index output.

* These are the absolute minimum-maximum AC supply voltage under any condition.

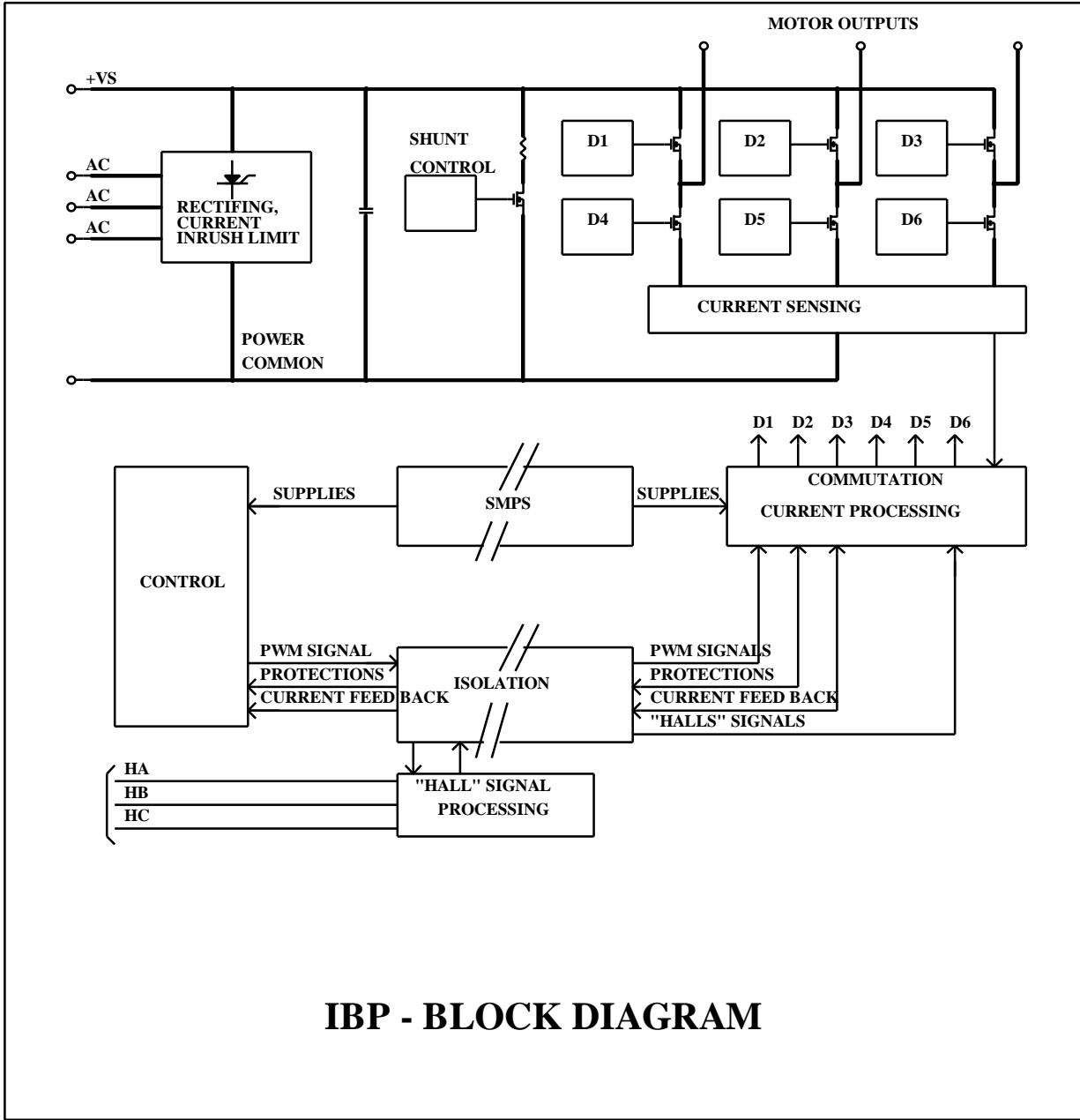

IBP - BLOCK DIAGRAM

4. Operation of the servo control

4.1 Inputs

The amplifier is equipped with 3 different gain inputs. Each input is buffered by a voltage follower having high input impedance to isolate the input from the rest of the circuit. Care must be taken not to apply input voltage above the maximum input voltage as this will cause the input op amp to operate beyond its limits ($\pm 10V$) and in extreme cases may even damage the op amp. The standard procedure recommended is to use input 3 for the velocity sensor and to use either input 1 or 2 for the reference signal.

The current gain of each input in velocity mode is given by:

$$G_v = \frac{133 \times I_p \times K_i}{(10 + R_{Si}) \times R_{19}} \quad (\text{Amp/Volt})$$

The current gain of each input in current mode is given by:

$$G_c = \frac{0.4 \times I_p \times K_i}{1 + 0.1 R_{Si}} \quad (\text{Amp/Volt})$$

I_p - Amplifier's rated peak current limit.

K_i - Position of wiper of trimming potentiometer (T1, T2, T3).

$K_i = 0$ when trimmer is fully CCW

$K_i = 1.0$ when trimmer is fully CW

R_{Si} - Series resistor of each input. Standard values are:

Input 1 - R1 (2.49Kohm)

Input 2 - R3 (15Kohm)

Input 3 - R5 (1Kohm)

Max. voltage (V_{in}) for each input can be calculated using the following relation:

$$V_{in} < R_{Si} (\text{ Volt/ KOHM}) + 10\text{Volt} \quad (\text{Volt})$$

R_{Si} in Kohm

The impedance of each input is given by:

$$R_{in} = 10 + R_{Si} \quad (\text{Kohm})$$

4.2 Velocity mode

In the velocity mode, op amp U3/A is employed as a high gain error amplifier. The amplifier sums the velocity command and the velocity feedback signal, and provides the necessary servo compensation and gain adjustments, resulting in stable, optimum servo operation. This op amp is configured with two feedback paths: One, in the form of a resistive T network, controls the DC gain of this amplifier. The equivalent value of a T network is given by:

$$R_f = \frac{10^{10}}{R_{19}} \quad (\text{Ohm})$$

Resistor R19 is mounted in solderless terminals so it can be changed easily whenever the DC gain of the error amplifier is to be changed. The AC gain is controlled by C5, R14 and T5. Maximum AC gain is obtained with T5 set fully CW. Setting T5 fully CCW removes AC gain and no lag in response occurs. R14 and C5 are mounted in solderless terminals and can be easily replaced in cases when T5 range is not enough to get optimum response. The output of the error amplifier is:

$$V_o = (V_1 G_{v1} + V_2 G_{v2} + V_3 G_{v3}) \times \left[\frac{1 + S \times C5 \times R14}{1 + S \times C5 \times R14 (1 + R_f \times K5 / R14)} \right]$$

V_1, V_2, V_3 - Input signals

G_{v1}, G_{v2}, G_{v3} - Gain of inputs.

K5 = Position factor of the wiper of T5.

Full CW = 1

Full CCW = 0.0

4.3 Velocity feedback sensors

Several types of sensors can be used for velocity feedback:

- Brush type tachogenerator.
- Three phase brushless tacho (30°/60° Hall effect can be selected).
- Two phase brushless tachogenerator: the control board accepts the two independent Hall effect signals for commutating the two windings.
- Tachsyn: the control board provides the oscillator for the Tachsyn.
- Resolver: A dedicated control board is installed when using a Resolver. A flexible oscillator for various types of Resolver is provided.

A filtering capacitor, C6, is placed in parallel to R14 to minimize noise carried on the input signals. This is specially beneficial when employing motors where a significant degree of electromagnetic coupling is present between armature and tachogenerator. Values in the range of 1000pF - 6800pF are recommended.

4.4 Current mode

In order to operate the servo amplifier as a current amplifier, the velocity loop is disabled. This is done by converting the error amplifier into a low gain DC amplifier which has a flat response beyond the desired current bandwidth.

4.5 Current feedback

Current feedback multiplier (CFM)

Current loop

Three current feedbacks are obtained by measuring the voltage drop across current sensing resistors (or by current transformers when using the isolation option). These three signals are synthesized and multiplexed which result in a single voltage signal proportional to phase currents. This is then compared with the error amplifier output. The error is processed by the current amplifier to provide a voltage command to the PWM section. The actual motor current can be monitored by turning DS8 to ON (DS7 must be OFF). The current monitor has the same scale when monitoring the current command or the current feedback.

Current loop control is obtained by op amp U3/B (current amplifier) and R33, C8 which form a lag-lead network for the current loop. The standard amp is

equipped with R33 and C8 to give optimum current response for an average motor in this power range. These components are mounted in solderless terminals.

The amplifier is equipped with a Current Feedback Multiplier (CFM). By turning DIP switch 2 (on the upper board of the power stage) to ON, the signal of the current feedback is multiplied by 2 and consequently the following changes occur:

- Current gains are multiplied by 2.
- Current monitor is divided by 2.
- Current limits are divided by 2.
- Dynamic range is improved.
- Commutation ripple is reduced.

This function should be activated whenever the rated current AND the peak current of the motor are less than 20% of the amplifier rated continuous and peak limits respectively.

Some times, oscillations may occur in current loop due to the fact that the feedback gain was multiplied. This can be resolved by substituting R33 with a lower value.

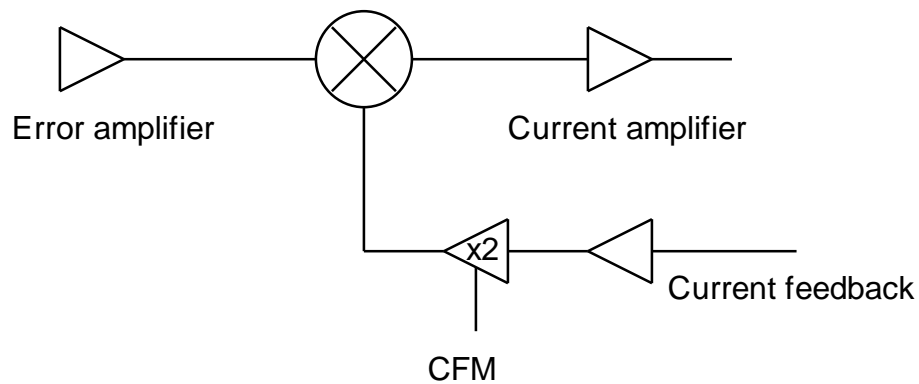

CFM BLOCK DIAGRAM

4.6 Current limits

The servo amplifier can operate in the following voltage-current plane:

| | | | |
|-------------------|-----------------|----|----|
| -Ip | -Ic | +V | Ip |
| Intermittent zone | Continuous zone | Ic | Ip |
| | | -V | |

Ic - Continuous current Ip - Peak current

Fig. 4.1: Voltage-Current plane

Each amplifier is factory adjusted to have this shape of voltage-current operating area with rated values of continuous and peak current limits. By using the adjusting trimmers it is possible to adjust the current limits (continuous and peak independently) from the rated values down to 10% of the rated values.

These current limits (continuous limit, or peak limit, or both) can also be controlled by an external current command. This analog input scales down the current limits from the preset current limits (trimmers setting) down to zero. In addition to these current limits functions, the amplifier has two additional features:

- * The peak current limit is time dependent.
- * Dynamic contouring of continuous and peak current limits.

These features are explained in 4.6.1 and 4.6.2.

4.6.1 Time dependent peak current limit

The peak current is so designed that its duration is a function of the peak amplitude and the motor operating current. The maximum peak current is available for 2 seconds. The duration of Ip is given by:

$$T_p = 3 \cdot \ln \frac{I_p - I_{op}}{I_p - I_c}$$

Ic - Amplifier continuous current rating.

I_p - Peak demanded (not amplifier I_p)

I_{op} - Actual operating current before the peak demand.

Example: A motor is driven by an IBP-10 amplifier at constant speed and constant current of 5A. What is the maximum possible duration of a 20A peak ?

$$20 - 5$$

$$T_p = 3 \cdot \ln \frac{20 - 5}{20 - 10} = 1.2 \text{ seconds}$$

$$20 - 10$$

4.6.2 Dynamic contouring of continuous and peak current limits.

Most of the servo motors have reduced continuous current limits at high speeds (Fig. 4.2). This phenomenon is due to iron losses which become significantly high as speed increases and this leads to reduction of the continuous current limit. The IBP amplifiers have the features which enable the user to define the current limit envelope as closely as possible to the motor operating envelope defined by the motor manufacturer. Complete discussion and procedures are given in Appendix C.

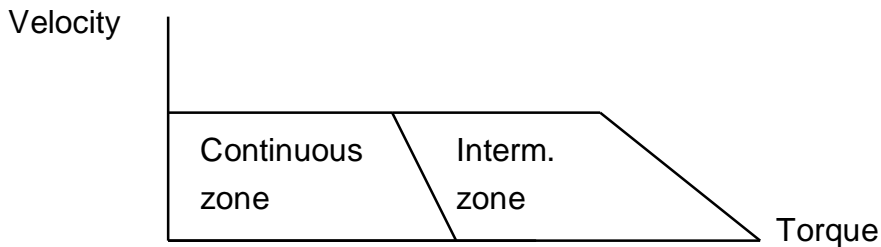

Fig. 4.2

Typical operating envelope of a brushless servo motor

4.7 Operation of the shunt regulator

A shunt regulator is included in the power supply section of the IBP. The shunt regulator is a switching type, wherein dissipative elements (resistors) are switched across the DC bus, whenever the voltage reaches a predetermined level (V_r). The function of the shunt regulator is to regulate the voltage of the DC bus during the period of motor deceleration, when there is a net energy outflow from the motor to the amplifier. The amplifier handles this reverse energy just as efficiently as it provides energy to the motor, hence, most of the energy is passed through the amplifier to the power supply, where the returning energy charges the filter capacitors above their normal voltage level, as determined by the AC incoming voltage.

When the capacitors charge-up reaches the predetermined voltage level (V_r), the shunt regulator begins its regulating action. The bus is regulated to this range until regeneration ceases.

All the double Eurocard size amplifiers are equipped with two outputs for connecting an external shunt resistor, hence increasing the power dissipation capability.

SHUNT specifications

| Type | Regulating Voltage (V_r) | Internal Reg. Current (A) | External Reg. Current (A) |
|-------------|------------------------------|---------------------------|---------------------------|
| IBP-12/135 | 193 | 13 | N/A |
| IBP-20/135 | 193 | 26 | 21 |
| IBP-8/270 | 383 | 8 | N/A |
| IBP-16/270 | 383 | 16 | 12 |
| IBPF-12/135 | 193 | 13 | N/A |
| IBPF-20/135 | 193 | 26 | 21 |
| IBPF-30/135 | 193 | 26 | 21 |
| IBPF-8/270 | 383 | 8 | N/A |
| IBPF-16/270 | 383 | 16 | 12 |
| IBPF-24/270 | 383 | 16 | 12 |

4.8 Commutation signals format

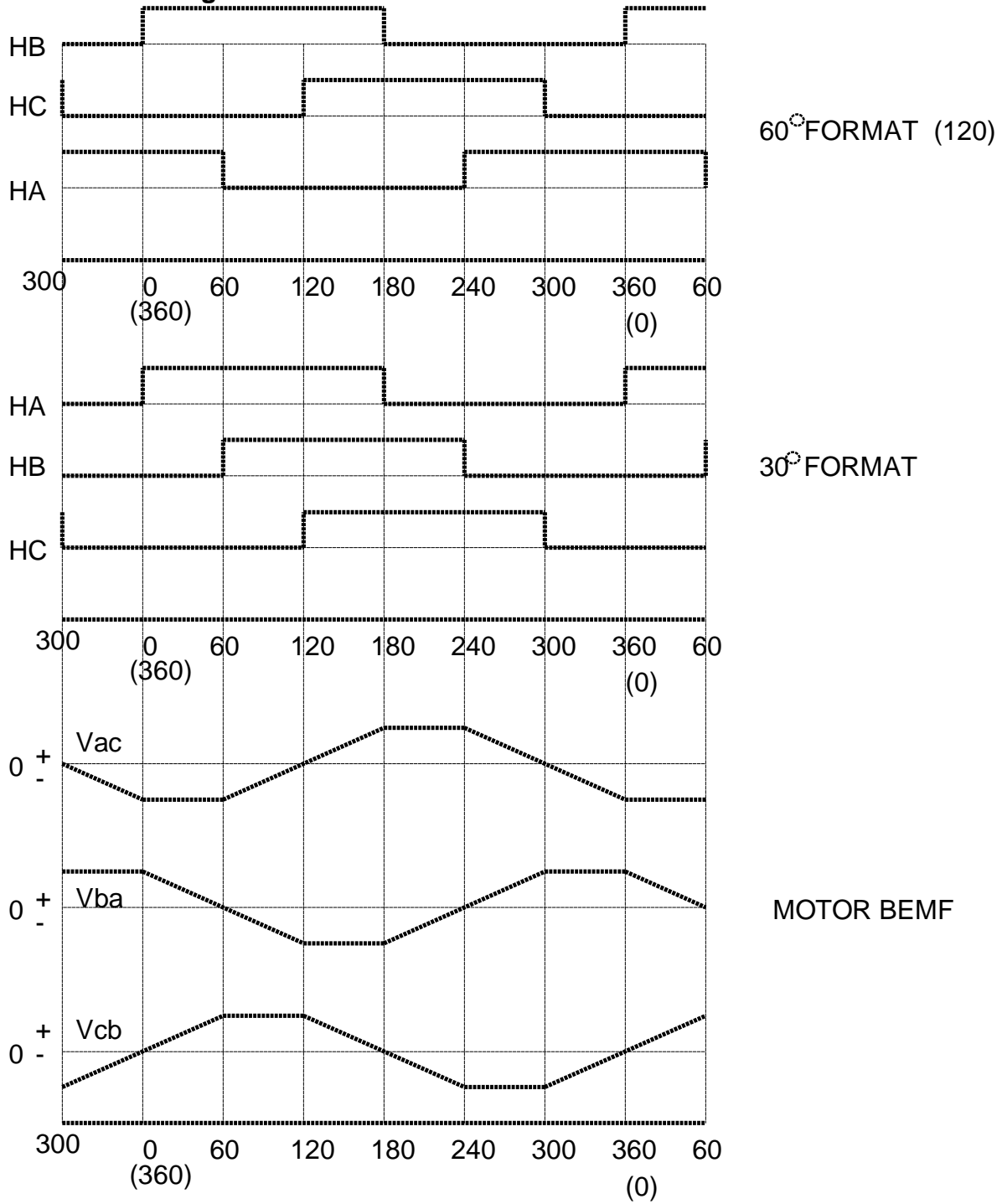

4.9 Protective functions

4.9.1 Short circuit protection

The short circuit protection uses the capability of the power MOSFET to tolerate high energy peaks for short periods of time. This protection is realized by sensing current in the DC line. Every current peak above a certain value will inhibit the amplifier for a period of approx. 30mS. If a short circuit condition still exists, the cycle will repeat endlessly while turning on the Short LED (Sh) to indicate the fault.

The amplifier is protected against shorts between outputs, either output to ground or to +Vs.

4.9.2 Under/over voltage protection

Whenever the DC bus voltage is under or over the limits indicated in the technical specifications, the amplifier will be inhibited.

4.9.3 Temperature protection

Temperature sensor is mounted on the heatsink. If, for any reason, the temperature exceeds 85°C the amplifier will be inhibited. The amplifier will restart when the temperature drops below 80°C.

4.9.4 Insufficient load inductance

Whenever the load inductance is too small, the current spikes will be very high. In such cases the amplifier will be disabled.

4.9.5 Loss of velocity feedback signal

If the amplifier loses the velocity feedback signal it will inhibit itself.

4.9.6 Internal power supply failure

In any case that the sum of the internal power supplies is below 13V or its difference higher than 1V, the amplifier will be inhibited.

4.9.7 Loss of commutation feedback

Lack of either of the commutation signals will inhibit the amplifier.

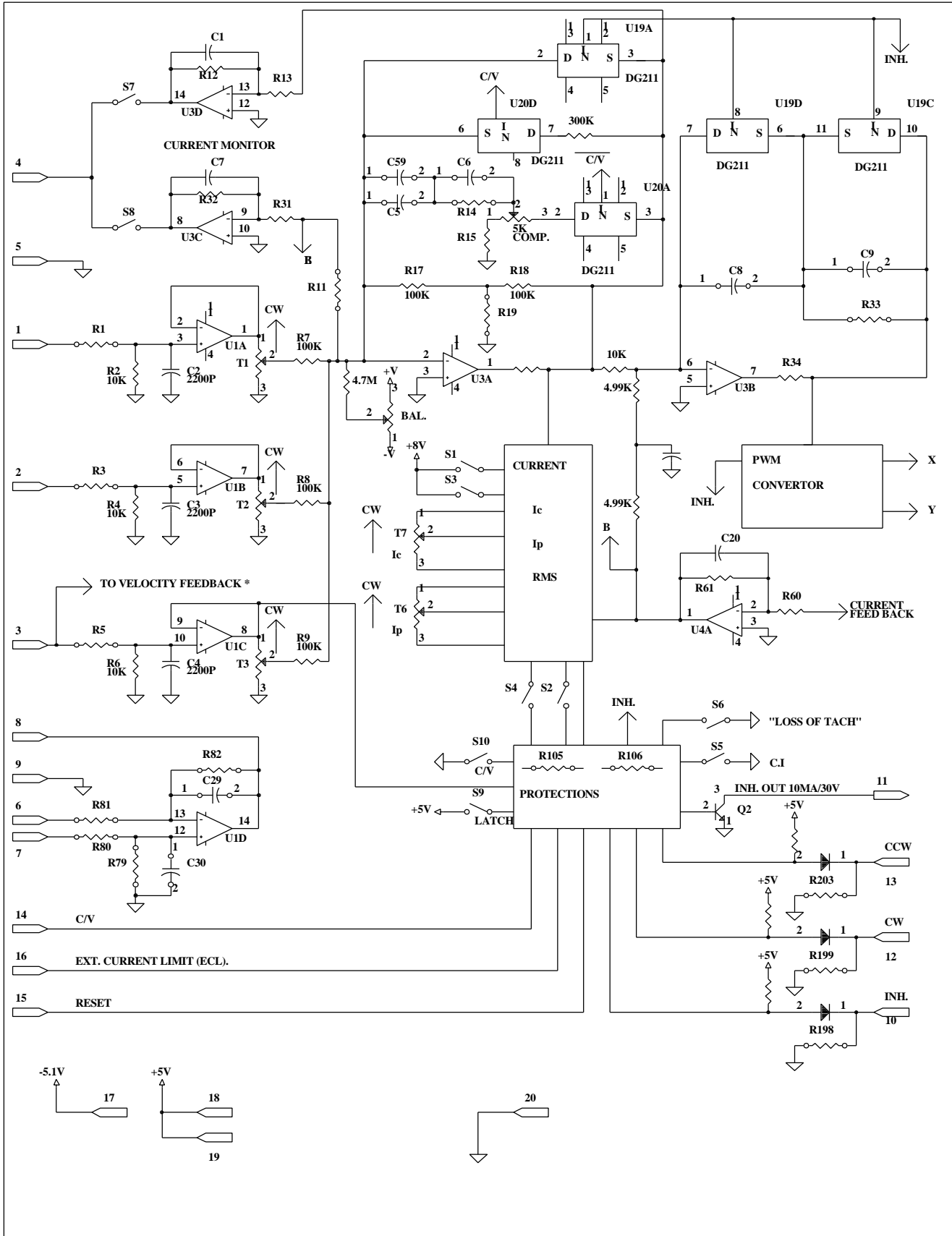

IBP CONTROL BOARD - LAYOUT

TACHSYN (T) VERSION

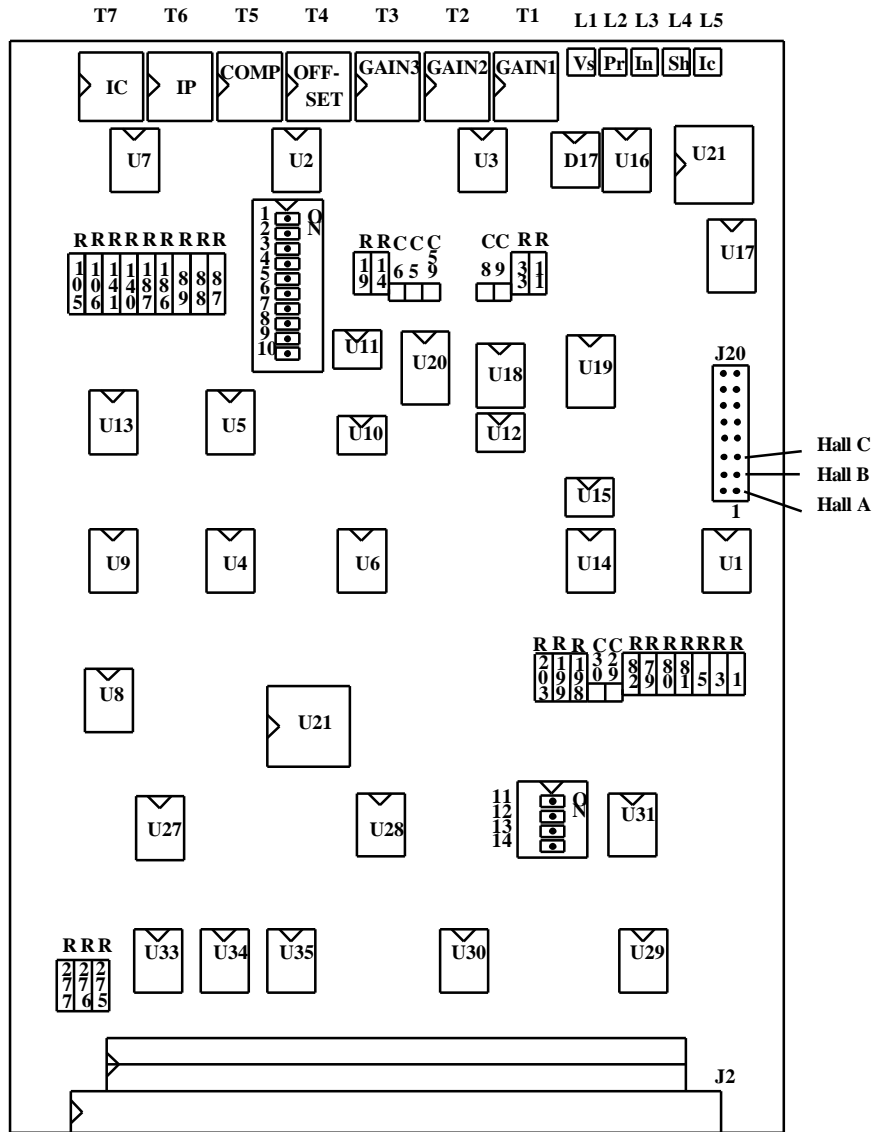

Note:
Some components will not be assembled
in H and B versions

IBP CONTROL BOARD - LAYOUT

RESOLVER (R) VERSION

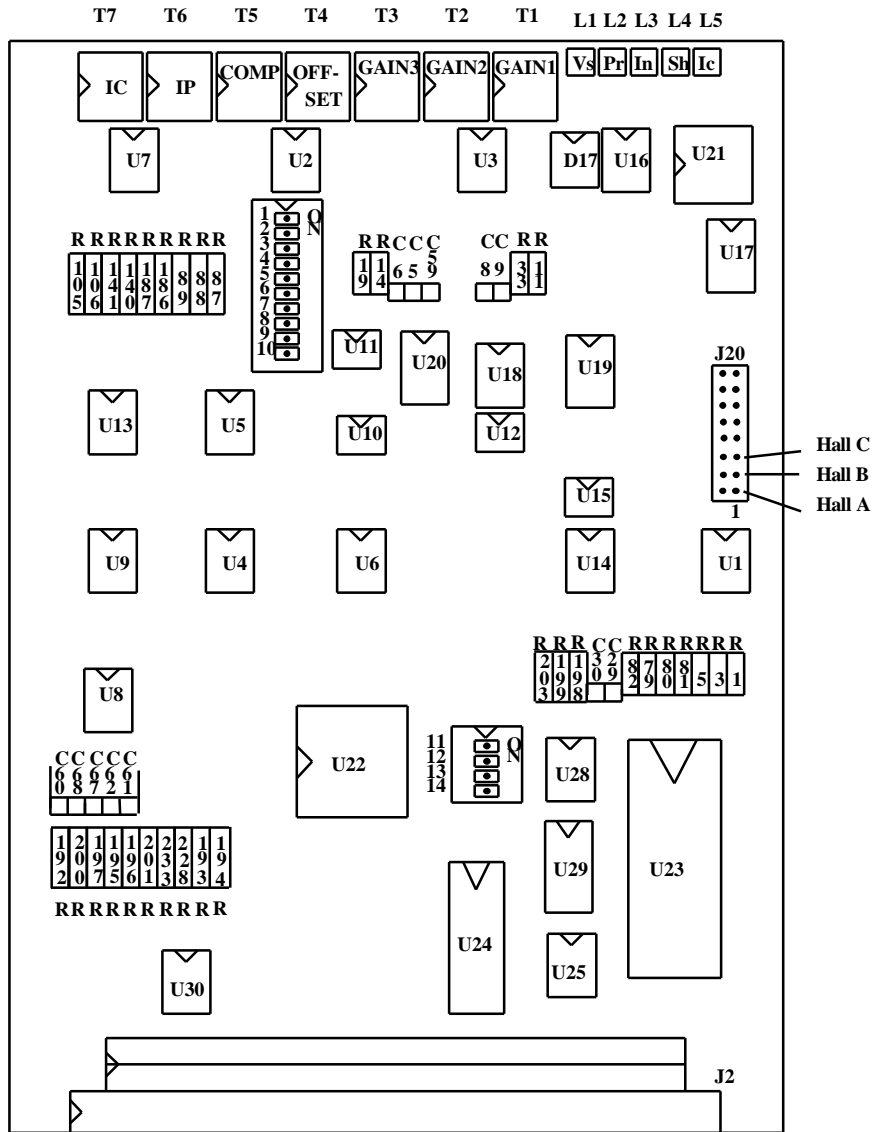

5. Terminal Description

5.1 Terminals for Horizontal and Rack mounting versions

POWER BOARD - 3U size

| H | R | Function |
|----|---------|---|
| 1 | (32a,c) | Motor phase A output. With the DIN connector both pins must be connected. |
| 2 | (30a,c) | Motor phase B output. With the DIN connector both pins must be connected. |
| 3 | (28a,c) | Motor phase C output. With the DIN connector both pins must be connected. |
| 4 | (26a,c) | AC supply-phase A. With the DIN connector both pins must be connected. |
| 5 | (24a,c) | AC supply-phase B. With the DIN connector both pins must be connected. |
| 6 | (22a,c) | AC supply-phase C. With the DIN connector both pins must be connected. |
| 7 | (20a,c) | DC power positive (+Vs) |
| 8 | (18a,c) | DC power common |
| 9 | 16a,c) | |
| 10 | (14c) | Hall sensor A * |
| 11 | (12c) | Hall sensor B * |
| 12 | (10c) | Hall sensor C * |
| 13 | (8c) | +15VDC for Hall sensors supply. |
| 14 | (6c) | Circuit common for the Hall sensors supply (Control common). |
| 15 | (4c) | 24V common - for the fan supply only. |
| 16 | (2c) | +24VDC, 400mA for use with brushless fan |

* $-1V \leq V_{il} < 1V$; $2V \leq V_{ih} < 30V$
 Source sink capability - 2mA min.

Power Board - 6U size - Motor terminals.

| H | R (J1) | FUNCTION |
|---|-----------------|---|
| 1 | 32ac, 30ac, 28c | MA - Motor phase A output. With the DIN connector all pins must be connected. |
| 2 | 26c, 24ac, 22ac | MB - Motor phase B output. With the DIN connector all pins must be connected. |
| 3 | 18ac, 16ac, 14a | MC - Motor phase C output. With the DIN connector all pins must be connected. |

Power Board - 6U size - Supplies terminals

| H | R (J3) | FUNCTION |
|--------|------------|---|
| 4 | 32ac, 30ac | AC supply-phase C. With the DIN connector all pins must be connected. |
| 5 | 26ac, 24ac | AC supply-phase B. With the DIN connector all pins must be connected. |
| 6 | 20ac, 18ac | AC supply-phase A. With the DIN connector all pins must be connected. |
| 7 | | NOT CONNECTED |
| 8, 9 | 14ac, 12ac | POWER COMMON |
| 10 | | NOT CONNECTED |
| 11 | 8ac | External shunt resistor connection. |
| 12 | | NOT CONNECTED |
| 13, 14 | 4ac, 2ac | +VS - External shunt resistor connection. |

Power Board - 6U size - Hall sensors and fan

| H | R (J1) | FUNCTION |
|----|--------|--|
| 15 | 10c | +FAN: +24VDC, 400mA for use with brushless fan |
| 16 | 8c | -FAN: 24V common - for the fan supply only |
| 17 | 6c | HA - Hall sensor A * |
| 18 | 4c | HB - Hall sensor B * |
| 19 | 2c | HC - Hall sensor C * |

* $-1V \leq V_{il} < 1V$; $2V \leq V_{ih} < 30V$

Source sink capability - 2mA min.

CONTROL BOARD(3U + 6U)

| H | R | Function |
|----|-------|---|
| 1 | (32a) | Input 1 - high gain. For more details see 7.1.5. |
| 2 | (32c) | Input 2 - mid gain. For more details see 7.1.5. |
| 3 | (30a) | Input 3 - low gain. For more details see 7.1.5. |
| 4 | (30c) | Motor current monitor. This output can be used to adjust the current limits of a motor without loading or measuring the actual motor current. For more details see 8.1. |
| 5 | (28a) | Circuit common |
| 6 | (28c) | Negative input of differential amplifier. For more details see Appendix C |
| 7 | (26a) | Positive input of differential amplifier. For more details see Appendix C |
| 8 | (26c) | Output of differential amplifier. For more details see Appendix C. |
| 9 | (24a) | Circuit common |
| 10 | (24c) | Inhibit input. This terminal provides a means of disabling the amplifier (both logic and power stages) by applying low level input voltage. For inverted logic see 7.1.3. * |
| 11 | (22a) | Inhibit indication output. Whenever the amplifier is inhibited, whether by an internal or external cause, this open collector output goes to low state (Max sink current 10mA, 30V max.). |

* $-1V \leq V_{il} < 1V$; $2V \leq V_{ih} < 30V$

Source sink capability - 2mA

CONTROL BOARD - cont.

| H | R | Function |
|----|-------|---|
| 12 | (22c) | CW disable. Low level input voltage will disable torque generation in one direction. For inverted logic see 7.1.3. * |
| 13 | (20a) | CCW disable. Low level input voltage will disable torque generation in one direction. For inverted logic see 7.1.3 * |
| 14 | (20c) | Velocity/Current mode selection: current mode when connected to circuit common) *See 7.1.4, 7.1.5. |
| 15 | (18a) | Reset. Low level input voltage will reset amplifier. * See 7.1.8. |
| 16 | (18c) | External current limit input (0-8V range). For more details see 8.1. |
| 17 | (16a) | -5.1V output, 10mA. |
| 18 | (16c) | +5V output, 0.5A. |
| 19 | (14a) | +5V output, 0.5A. |
| 20 | (14c) | Circuit common |

Terminals for H,B,T versions (hall effect, brushless tach or Tachsyn)

| H | R | Function |
|----|-------|--|
| 21 | (12a) | Circuit common. |
| 22 | (12c) | +15V <u>+</u> 5% output, 100mA. |
| 23 | (10a) | -15V <u>+</u> 5% output, 100mA. |
| 24 | (10c) | Hall A input for two phase brushless tach. |
| 25 | (8a) | Hall B input for two phase brushless tach. |
| 26 | (8c) | Phase A brushless tach. See 7.2.2. |
| 27 | (6a) | Phase B brushless tach. See 7.2.2. |

* $-1V \leq V_{il} < 1V$; $2V \leq V_{ih} < 30V$

Source sink capability - 2mA

CONTROL BOARD, Terminals for H,B,T versions - cont.

| H | R | Function |
|----|------|--|
| 28 | (6c) | Phase C brushless tacho. See 7.2.2. |
| 29 | (4a) | Tacho common. (circuit common) See 7.2.2. |
| 30 | (4c) | Circuit common. |
| 31 | (2a) | Oscillator output for Tachsyn only. See 7.2.3. |
| 32 | (2c) | Velocity monitor. See 7.2.2. |

Terminals for R (Resolver) version

| H | R | Function |
|----|-------|--|
| 21 | (12a) | +15V +5% output, 100mA. |
| 22 | (12c) | -15V +5% output, 100mA. |
| 23 | (10a) | Sine signal input |
| 24 | (10c) | Sine signal common |
| 25 | (8a) | Cosine signal input |
| 26 | (8c) | Cosine signal common |
| 27 | (6a) | Reference oscillator output (7.5V/60mA max, RMS) |
| 28 | (6c) | Reference oscillator common |
| 29 | (4a) | Channel A output, 5V/+10mA max. |
| 30 | (4c) | Channel B output, 5V/+10mA max. |
| 31 | (2a) | Channel I output (index), 5V/+10mA max. |
| 32 | (2c) | Velocity monitor. See chapter 7.2.4 - Velocity signal. |

Remark: In the following paragraphs the terminals will be related to all the mounting types as in the following example:

H-32,R-2c,E-J1/8.

TERMINALS LAYOUT

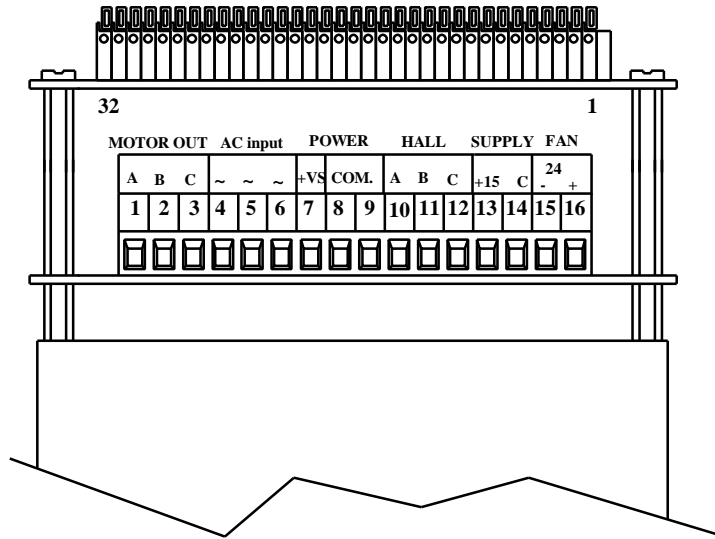

IBP - PANEL (H) MOUNTING TYPE

EUROCARD SIZE TYPES

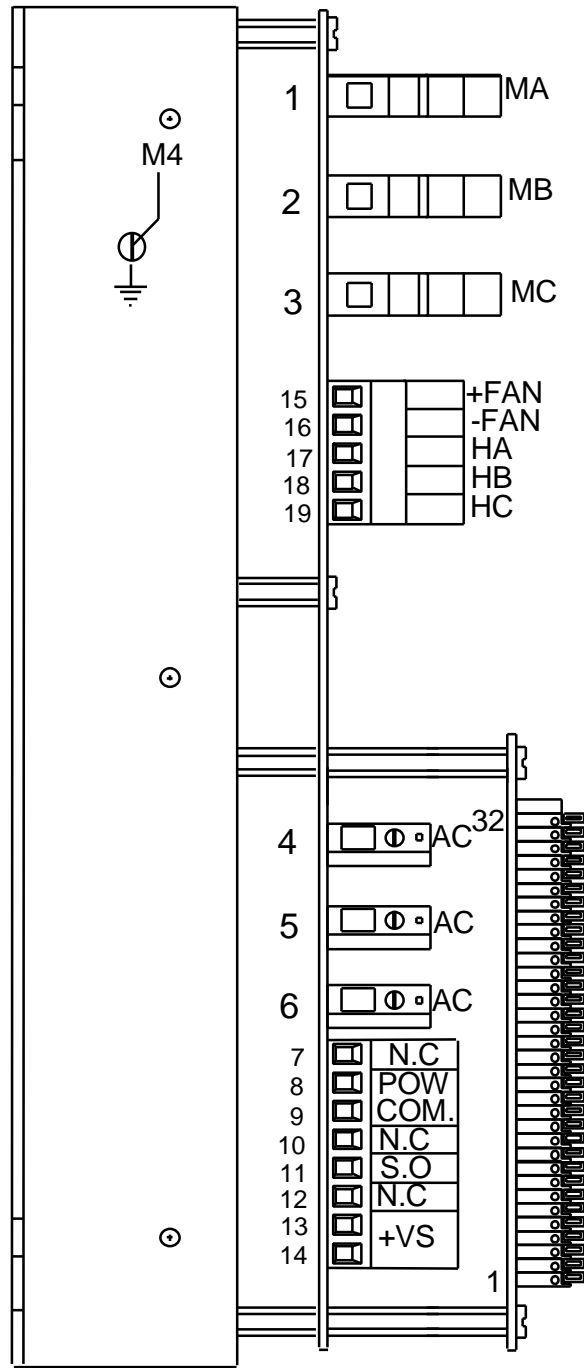

**IBP- PANEL (H) MOUNTING TYPE
DOUBLE EUROCARD SIZE**

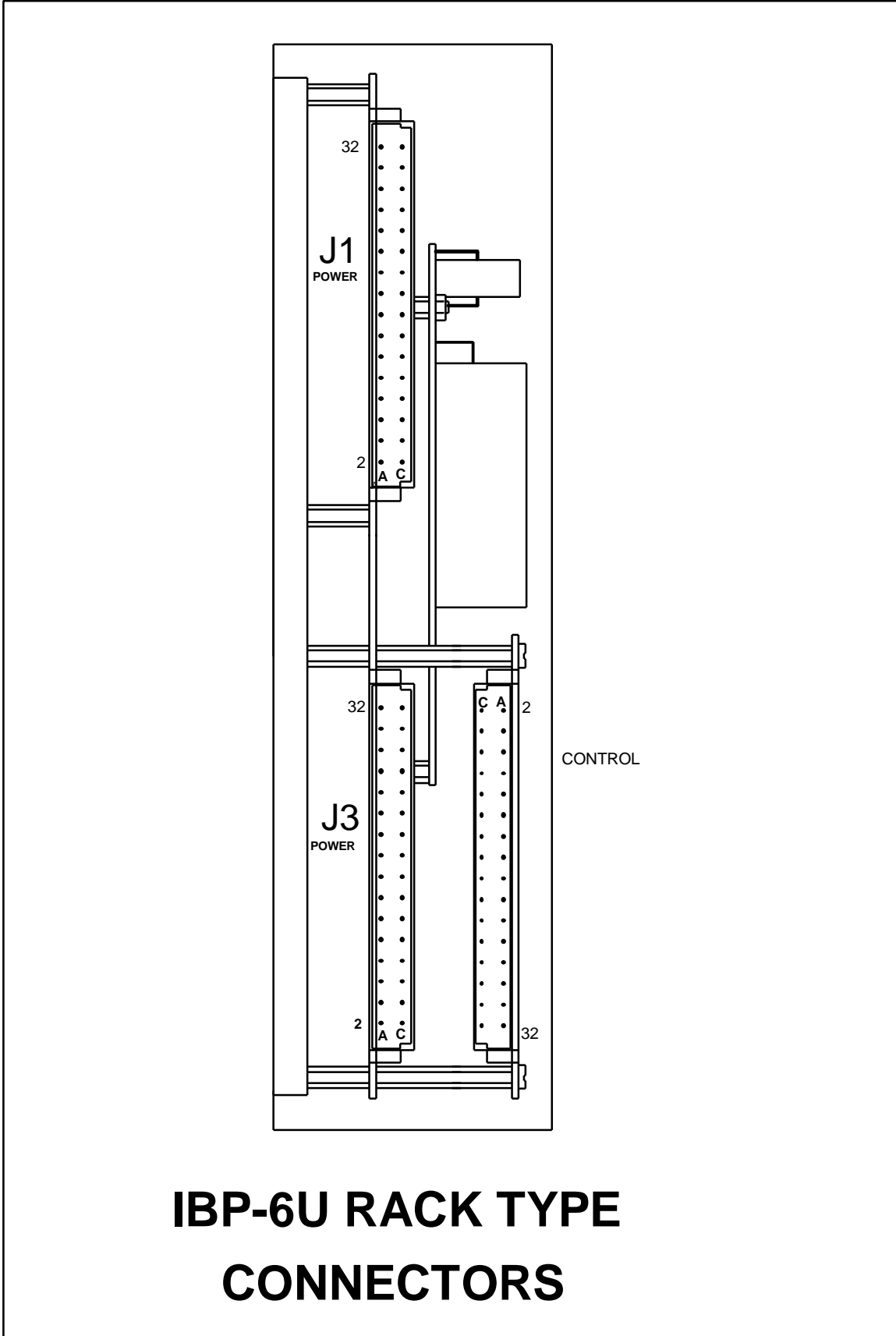

IBP-6U RACK TYPE CONNECTORS

5.2 Mother Boards terminals

All the mother boards include a terminal to connect the GROUND. This terminal must always be connected.

This way, the grounding of the rack, the heatsink and the front panel is accomplished.

All the 3U mother boards, include a key for protecting against a possible inverted mounting of the amplifier into the rack.

The following mother boards are available to complement the IBP rack version amplifiers:

5.2.1 MBA-IBP/3UB

Use: For all IBP amplifiers in 3U size and with brushless tacho or Tachsyn interface.

Termination: Screw type connectors for both power and signals.

Terminal designation: identical to the panel versions except the following new terminals:

| | |
|-------|---|
| 33 | Relay contact (potential free). |
| 34 | Relay contact (potential free). The relay contact is closed whenever the amplifier is enabled. Contact rating: 0.5A, 200V, 10W. |
| 41 | Potential free Inhibit Input (+). See 7.1.3. |
| 42 | Potential free Inhibit Input (-). See 7.1.3. |
| 35-40 | Not applicable. |

The Potential Free Inhibit Input is applicable only when the "inverted inhibit logic" is used (R198 in the amplifier is inserted). An opto-Coupler (IL5) is used to isolate between the Inhibit signal and the amplifier circuit. Activating this opto-coupler is done by inserting R12 on the mother board according to the following relation:

$$R12 = 100 \times V_{inh} \text{ (ohm)}$$

Vinh - voltage in the inhibit input.

Standard value is 2.4K (For 24 volts) Source must be capable of source or sink 10mA.

5.2.2 MBA-IBP/3UB1

Use: For all IBP amplifiers in 3U size and with brushless tacho or Tachsyn interface where linear Acc/Dec are required.

Acc/Dec adjustment: 5 preset ramps selectable by DIP switches.

Termination: Screw type connectors for both power and signals. Terminals designation: identical to the panel versions except the following new terminals:

| | |
|-------|---|
| 33 | Relay contact (potential free). |
| 34 | Relay contact (potential free). The relay contact is closed whenever the amplifier is enabled. Contact rating: 0.5A, 200V, 10W. |
| 41 | Potential free Inhibit Input (+). See 7.1.3. |
| 42 | Potential free Inhibit Input (-). See 7.1.3. |
| 35-40 | Not applicable. |

The Potential Free Inhibit Input is applicable only when the "inverted inhibit logic" is used (R198 in the amplifier is inserted). An opto-Coupler (IL5) is used to isolate between the Inhibit signal and the amplifier circuit. Activating this opto-coupler is done by inserting R12 on the mother board according to the following relation:

$$R12 = 100 \times V_{inh} \text{ (ohm)}$$

Vinh - voltage in the inhibit input.

Standard value is 2.4K (For 24 volts) Source must be capable of source or sink 10mA.

5.2.3 MBA-IBP/3UR

Use: For all IBP amplifiers in 3U size and with Resolver interface. The encoder outputs are driven by line drivers to improve noise immunity.

Termination: Screw type connectors for both power and signals. Terminals designation: identical to the panel versions except the following new terminals:

| | |
|----|---|
| 33 | Relay contact (potential free). |
| 34 | Relay contact (potential free). The relay contact is closed whenever the amplifier is enabled. Contact rating: 0.5A, 200V, 10W. |
| 35 | Buffered channel A output (20mA, 0-5V) |
| 36 | Buffered channel -A output (20mA, 0-5V) |
| 37 | Buffered channel B output (20mA, 0-5V) |
| 38 | Buffered channel -B output (20mA, 0-5V) |
| 39 | Buffered Index output (20mA, 0-5V) |
| 40 | Buffered -Index output (20mA, 0-5V) |
| 41 | Potential free Inhibit Input (+). See 7.1.3. |
| 42 | Potential free Inhibit Input (-). See 7.1.3. |

The Potential Free Inhibit Input is applicable only when the "inverted inhibit logic" is used (R198 in the amplifier is inserted). An opto-Coupler (IL5) is used to isolate between the Inhibit signal and the amplifier circuit. Activating this opto-coupler is done by inserting R12 on the mother board according to the following relation:

$$R12 = 100 \times V_{inh} \text{ (ohm)}$$

Vinh - voltage in the inhibit input.

Standard value is 2.4K (For 24 volts) Source must be capable of source or sink 10mA.

5.2.4 MBA-IBP/3UR1

Use: For all IBP amplifiers in 3U size and with Resolver interface.

Acc/Dec adjustment: 5 preset ramps selectable by DIP switches.

Termination: Screw type connectors for both power and signals.

Terminals designation: like MBA-IBP/3UR

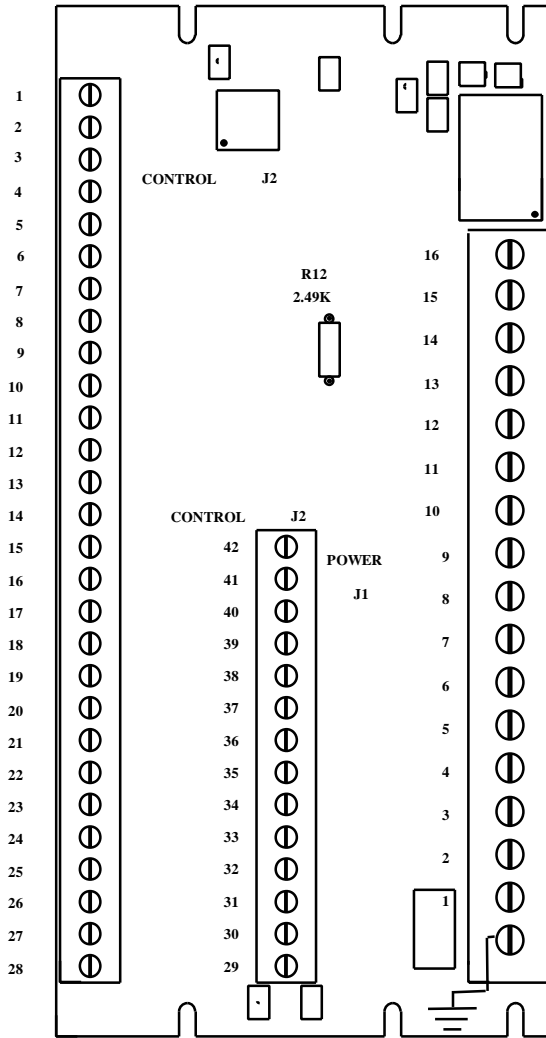

MBA - IBP/3UB

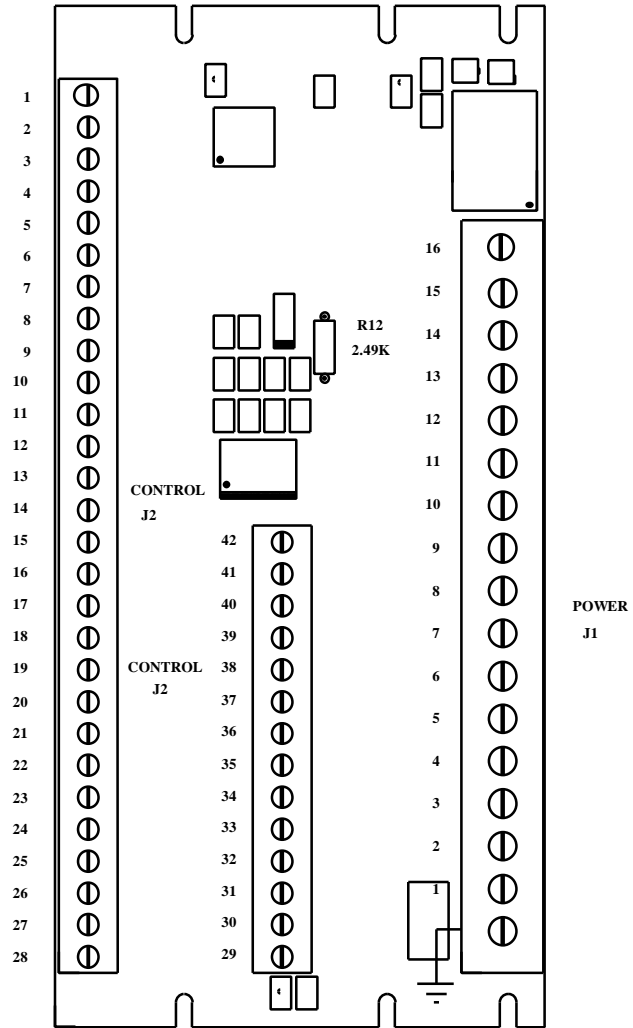

MBA - IBP/3UR

5.2.5 MBA-IBP/6UB

Use: for all IBP amplifiers in 6U size and with brushless tachometer or Tachsyn interface.

Termination: Screw type connectors for both power and signals.

Terminals designation:

J2 - Identical to the signals terminals in the panel versions with additional new terminals:

| | |
|-------|---|
| 33 | Relay contact (potential free). |
| 34 | Relay contact (potential free). The relay contact is closed whenever the amplifier is enabled. Contact rating: 0.5A, 200V, 10W. |
| 41 | Potential free Inhibit Input (+). See 7.1.3. |
| 42 | Potential free Inhibit Input (-). See 7.1.3. |
| 35-40 | Not applicable. |

J1A - Fan and Hall sensors

| | |
|----|---|
| 6 | Hall sensor A * |
| 7 | Hall sensor B * |
| 8 | Hall sensor C * |
| 12 | Circuit common for +15V supply |
| 13 | +15V supply, 100mA |
| 14 | 24VDC common - fan only. |
| 15 | +24VDC isolated supply for fan (max. 400mA) |

* $-1V \leq V_{il} < 1V$; $2V \leq V_{ih} < 30V$

Source sink capability - 2mA

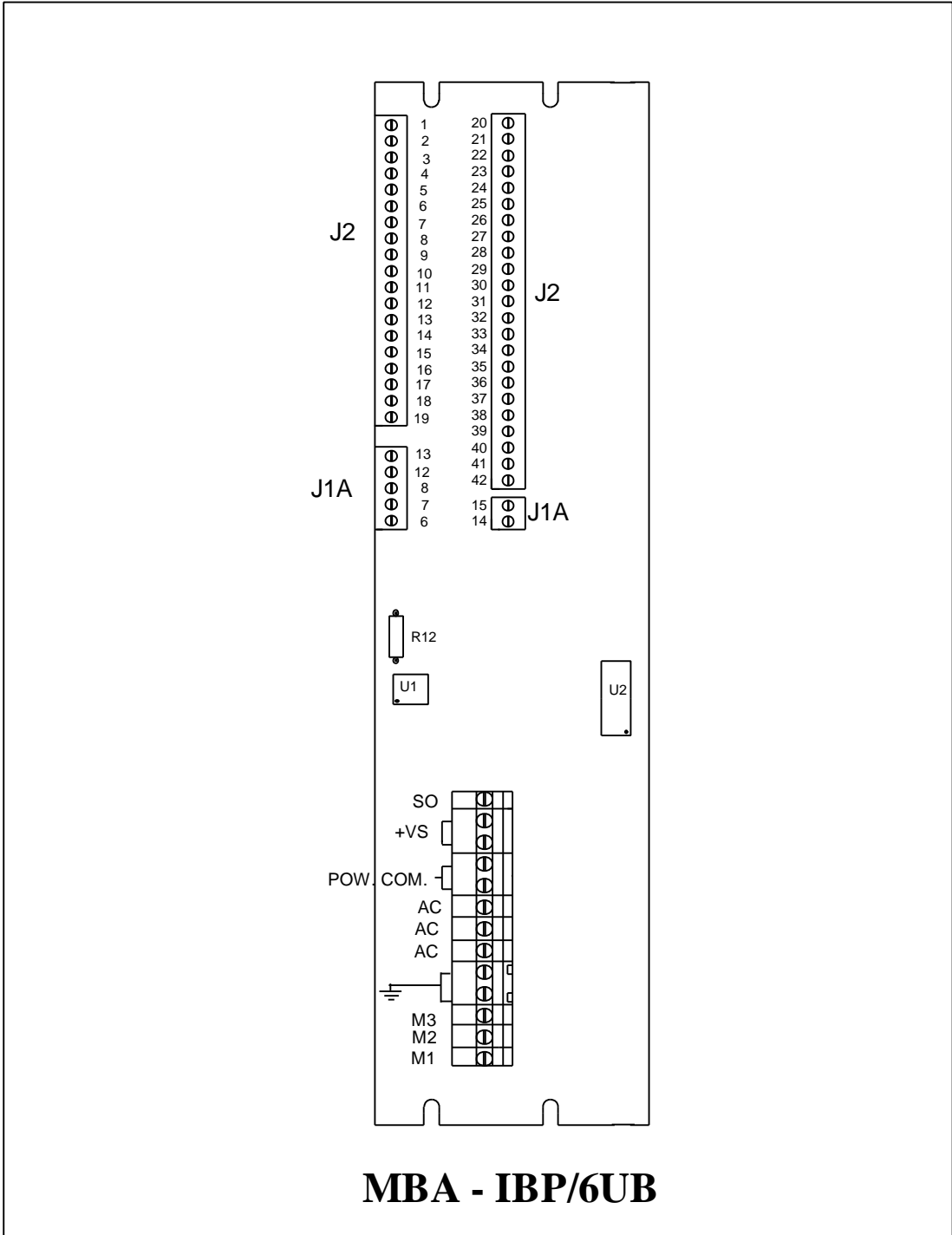

MBA - IBP/6UB

5.2.6 MBA-IBP/6UR

Use: For all IBP amplifiers in 6U size and with Resolver interface.

Termination: Screw type connectors for both power and signals.

Terminals designation:

J2 - identical to the signals terminals in the panel versions with additional new terminals:

| | |
|----|---|
| 33 | Relay contact (potential free). |
| 34 | Relay contact (potential free). The relay contact is closed whenever the amplifier is enabled. Contact rating: 0.5A, 200V, 10W. |
| 35 | Buffered channel A output (20mA, 0-5V) |
| 36 | Buffered channel -A output (20mA, 0-5V) |
| 37 | Buffered channel B output (20mA, 0-5V) |
| 38 | Buffered channel -B output (20mA, 0-5V) |
| 39 | Buffered Index output (20mA, 0-5V) |
| 40 | Buffered -Index output (20mA, 0-5V) |
| 41 | Potential free Inhibit Input (+). See 7.1.3. |
| 42 | Potential free Inhibit Input (-). See 7.1.3. |

J1A - Fan supply

| | |
|------|---|
| 6-13 | Not applicable |
| 14 | 24VDC common - fan only. |
| 15 | +24VDC isolated supply for fan (max. 400mA) |

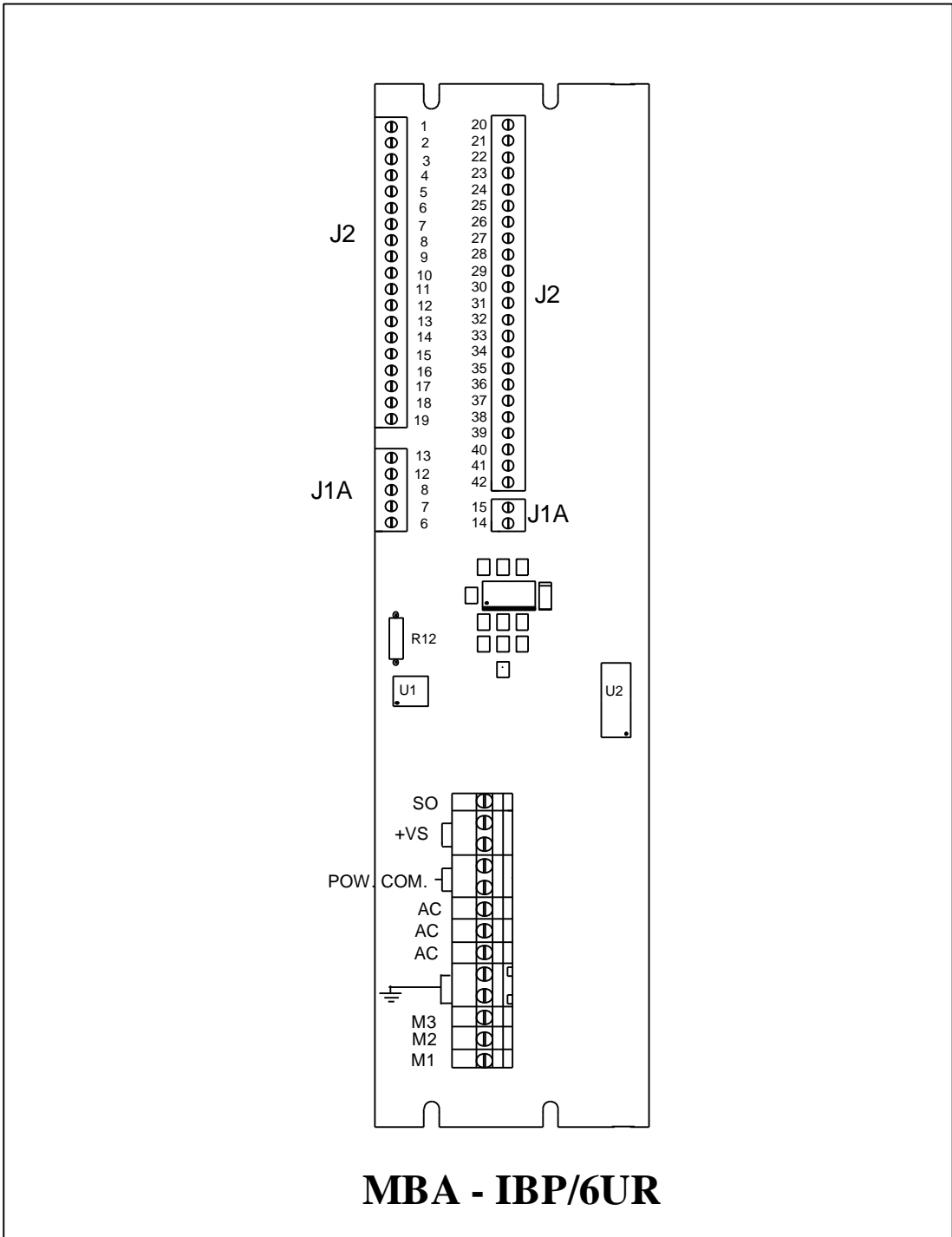

MBA - IBP/6UR

5.3 Terminals for IBP mounted in ENC.

Attention: DC power commons, control commons and fan common are floating with respect to each other. Do not short them unless specified.

5.3.1 Power connector 3U size - J6

| Terminal | Function |
|----------|---|
| 1 | Motor phase A output. |
| 2 | Motor phase B output. |
| 3 | Motor phase C output. |
| 4 | AC supply-phase A. |
| 5 | AC supply-phase B. |
| 6 | AC supply-phase C. |
| 7 | DC power positive |
| 8,9 | DC power common |
| 10,11 | Ground. These terminals are connected to the ENC chassis. |

5.3.2 Power connector 6U size - J6

| Terminal | Function |
|----------|--|
| M1 | Motor phase A output. |
| M2 | Motor phase B output. |
| M3 | Motor phase C output. |
| GND | Ground. This terminal is connected to the ENC chassis. |
| AC | AC supply-phase A. |
| AC | AC supply-phase B. |
| AC | AC supply-phase C. |
| COM | DC power common |
| VS | DC power positive |
| SO | Auxiliary shunt output, for external shunt resistor. |

5.3.3 Signal connectors - Brushless Tacho, Tachsyn

Signal connector J1 (ENC)

| Connector/p in | Function |
|-------------------|--|
| 1 | Input 1 - high gain. For more details see 7.1.5. |
| 2 | Input 2 - mid gain. For more details see 7.1.5. |
| 3 | Input 3 - low gain. For more details see 7.1.5. |
| 4 | Negative input of differential amplifier. For more details see Appendix C. |
| 5 | Positive input of differential amplifier. For more details see Appendix C. |
| 6 | Not connected |
| 7 | Output of differential amplifier. See Appendix C. |
| 8 | Velocity monitor. See 7.2.2. |
| 9 | Motor current monitor. This output can be used to adjust the current limits of a motor without loading or measuring the actual motor current. For more details see 8.1. |
| 10 | External current limit input (0-8V range). For more details see 8.1. |
| 11 | Velocity/Current mode selection (current mode when connected to circuit common). See 7.1.4, 7.1.5. |
| 12 | -5.1V output, 10mA. |
| 13 | Not connected |
| 14,15 16,17 | Circuit common |
| 18,19 | +15V +5% output, 100mA. |
| 20 | +5V output, 0.5A. |
| 21 | -15V +5% output, 100mA. |
| 22,23 24,25 | Circuit common |

Signal connector J2 (ENC)

| Connector/p in | Function |
|-------------------|---|
| 1,14 | Inhibit output. A potential free relay contact-Closed when amplifier is enabled. Contact rating: 0.5A, 200V, 10W. |
| 2,3,4,5, 6,7 | Not connected |
| 8 | Potential free Inhibit Input (-). See 7.1.3. |
| 9 | Potential free Inhibit Input (+). See 7.1.3. |
| 10 | Reset (*). Low level input voltage will reset amplifier. See 7.1.8. |
| 11 | CCW disable Low level input voltage* will disable torque generation in one direction(*). For inverted logic see 7.1.3. |
| 12 | CW disable Low level input voltage will disable torque generation in one direction. For inverted logic see 7.1.3. |
| 13 | Inhibit input. This terminal provides a means of disabling the amplifier (both logic and power stages) by applying low level input voltage. (*) For inverted logic see 7.1.3 |
| 15,16,17 | Circuit common |
| 18 | -15V +5% output, 100mA. |
| 19 | +5V output, 0.5A. |
| 20,21 | +15V +5% output, 100mA. |
| 22,23 | Circuit common |
| 24,25 | |

* $-1V \leq V_{il} < 1V$; $2V \leq V_{ih} < 30V$

Source sink capability - 2mA

* $-1V \leq V_{il} < 1V$; $2V \leq V_{ih} < 30V$

Source sink capability - 2mA

Feedback connector J3 (ENC)

| Connector/p in | Function |
|-------------------|--|
| 1 | Hall A input of two phase brushless tach. * |
| 2 | Phase A for brushless tach. |
| 3 | Phase C for brushless tach. |
| 4 | Oscillator output for Tachsyn only. |
| 5 | +5V |
| 6 | Circuit common |
| 7 | Hall A input * |
| 8 | Hall C input * |
| 9 | Hall B input for two phase brushless tach. * |
| 10 | Phase B brushless tach. |
| 11 | Tach common. (circuit common) |
| 12 | Circuit common. |
| 13 | +15V +5% output, 100mA. |
| 14 | -15V +5% output, 100mA. |
| 15 | Hall B |

5.3.4 Signals connectors - Resolver version

Signal connector J1

| Connector/p in | Function |
|-------------------|---|
| 1 | Input 1 - high gain. For more details see 7.1.5. |
| 2 | Input 2 - mid gain. For more details see 7.1.5. |
| 3 | Input 3 - low gain. For more details see 7.1.5. |
| 4 | Negative input of differential amplifier. For more details see Appendix C. |
| 5 | Positive input of differential amplifier. For more details see Appendix C. |

Signal connector J1 (ENC) - cont.

| | |
|----------------|--|
| 6 | Not connected |
| 7 | Output of differential amplifier. For more details see Appendix C. |
| 8 | Velocity monitor. See chapter 7.2.4 - Velocity signal. |
| 9 | Motor current monitor. This output can be used to adjust the current limits of a motor without loading or measuring the actual motor current. For more details see 8.2. |
| 10 | External current limit input (0-8V range). For more details see 8.1. |
| 11 | Velocity/Current mode selection (current mode when connected to circuit common). See 7.1.4, 7.1.5. |
| 12 | -5.1V output, 10mA. |
| 13 | Not connected |
| 14,15 16,17 | Circuit common |
| 18,19 | +15V +5% output, 100mA. |
| 20 | +5V output, 0.5A. |
| 21 | -15V +5% output, 100mA. |
| 22,23 24,25 | Circuit common |

Signal connector J2 (ENC)

| Connector/ pin | Function |
|-------------------|--|
| 1,14 | Inhibit output. A potential free relay contact-Closed when amplifier is enabled. Contact rating: 0.5A, 200V/10W. |
| 2 | Buffered channel -I output, +20mA max. |
| 3 | Buffered channel I output (index), +20mA max. |
| 4 | Buffered channel -B output, +20mA max. |
| 5 | Buffered channel B output, +20mA max. |
| 6 | Buffered channel -A output, +20mA max. |
| 7 | Buffered channel A output, +20mA max. |

Signal connector J2 (ENC) - cont.

| | |
|----------|--|
| 8 | Potential free Inhibit Input (-). See 7.1.3. |
| 9 | Potential free Inhibit Input (+). See 7.1.3. |
| 10 | Reset (*). Low level input voltage will reset amplifier. See 7.1.8. |
| 11 | CCW disable Low level input voltage will disable torque generation in one direction. * For inverted logic see 7.1.3 |
| 12 | CW disable Low level input voltage will disable torque generation in one direction. * For inverted logic see 7.1.3 |
| 13 | Inhibit input This terminal provides a means of disabling the amplifier (both logic and power stages) by applying low level input voltage (*). For inverted logic see 7.1.3. |
| 15,16,17 | Circuit common |
| 18 | -15V +5% output, 100mA. |
| 19 | +5V output, 0.5A. |
| 20,21 | +15V +5% output, 100mA. |
| 22,23 | Circuit common |
| 24,25 | |

* $-1V \leq V_{il} < 1V$; $2V \leq V_{ih} < 30V$
Source sink capability - 2mA

Feedback connector J3

| Connector/p in | Function |
|-------------------|--|
| 1 | Sine signal input |
| 2 | Cosine signal input |
| 3 | Reference oscillator output (7.5V/60mA max, RMS) |
| 4 | Not connected |
| 5 | +5V output, 0.5A. |
| 6 | Circuit common |
| 7,8,15 | Not connected |
| 9 | Sine signal common |
| 10 | Cosine signal common |
| 11 | Reference oscillator common |
| 12 | Circuit common. |
| 13 | +15V +5% output, 100mA. |
| 14 | -15V +5% output, 100mA. |

Remark: In the following paragraphs the terminals will be related to all the mounting types as in the following example:

H-32,R-2c,E-J1/8.

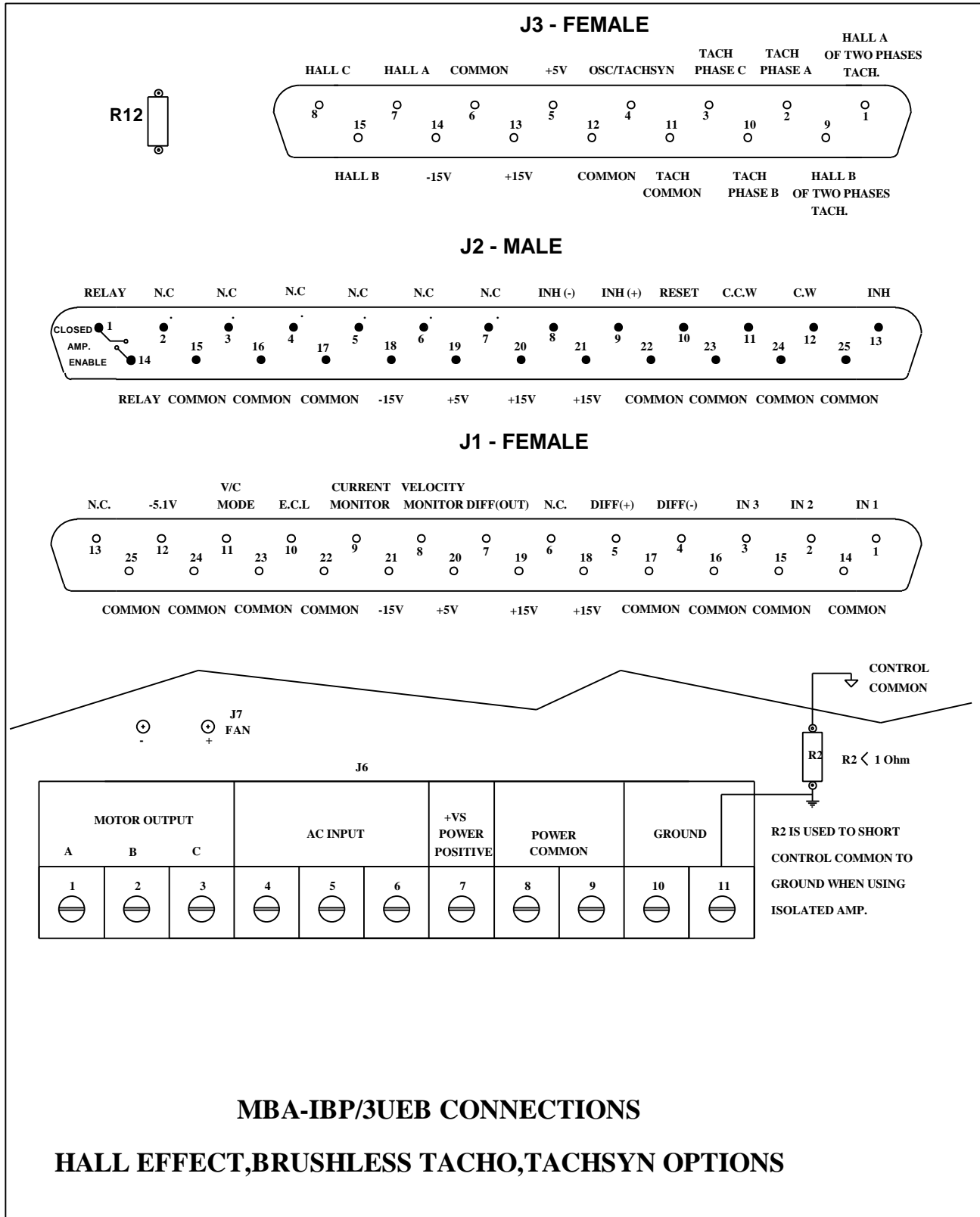

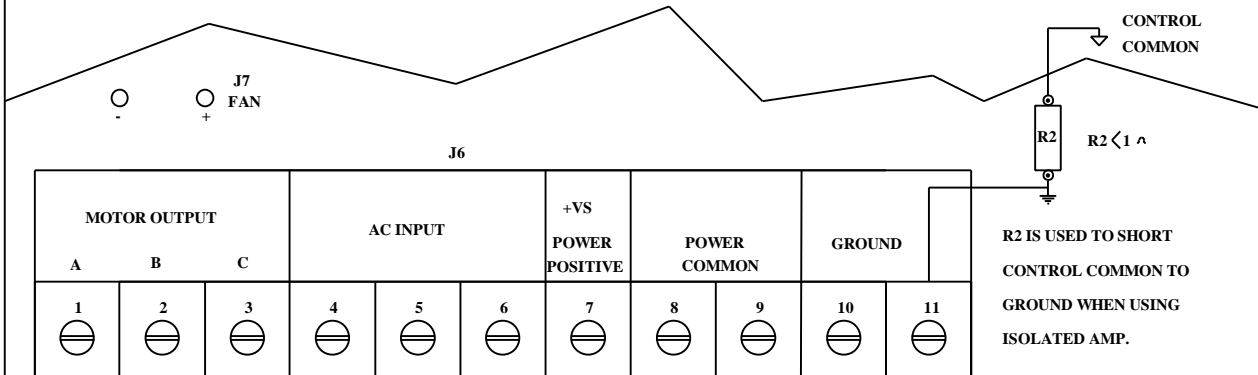
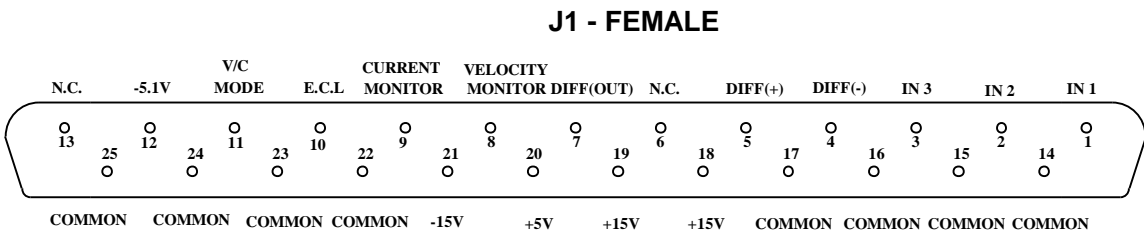
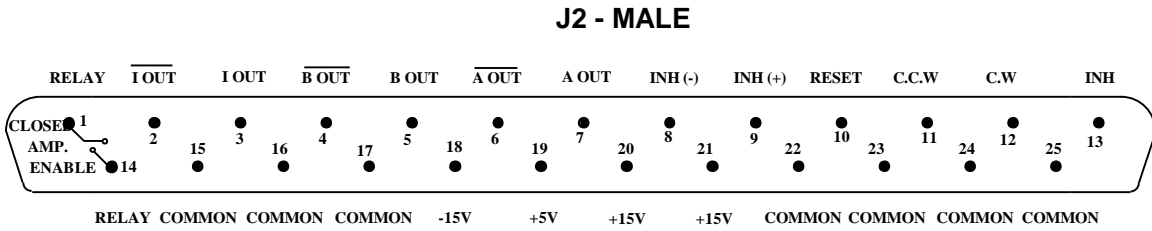
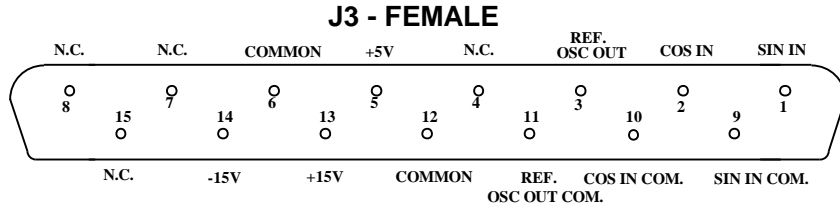

MBA-IBP/3UER CONNECTIONS

RESOLVER OPTION

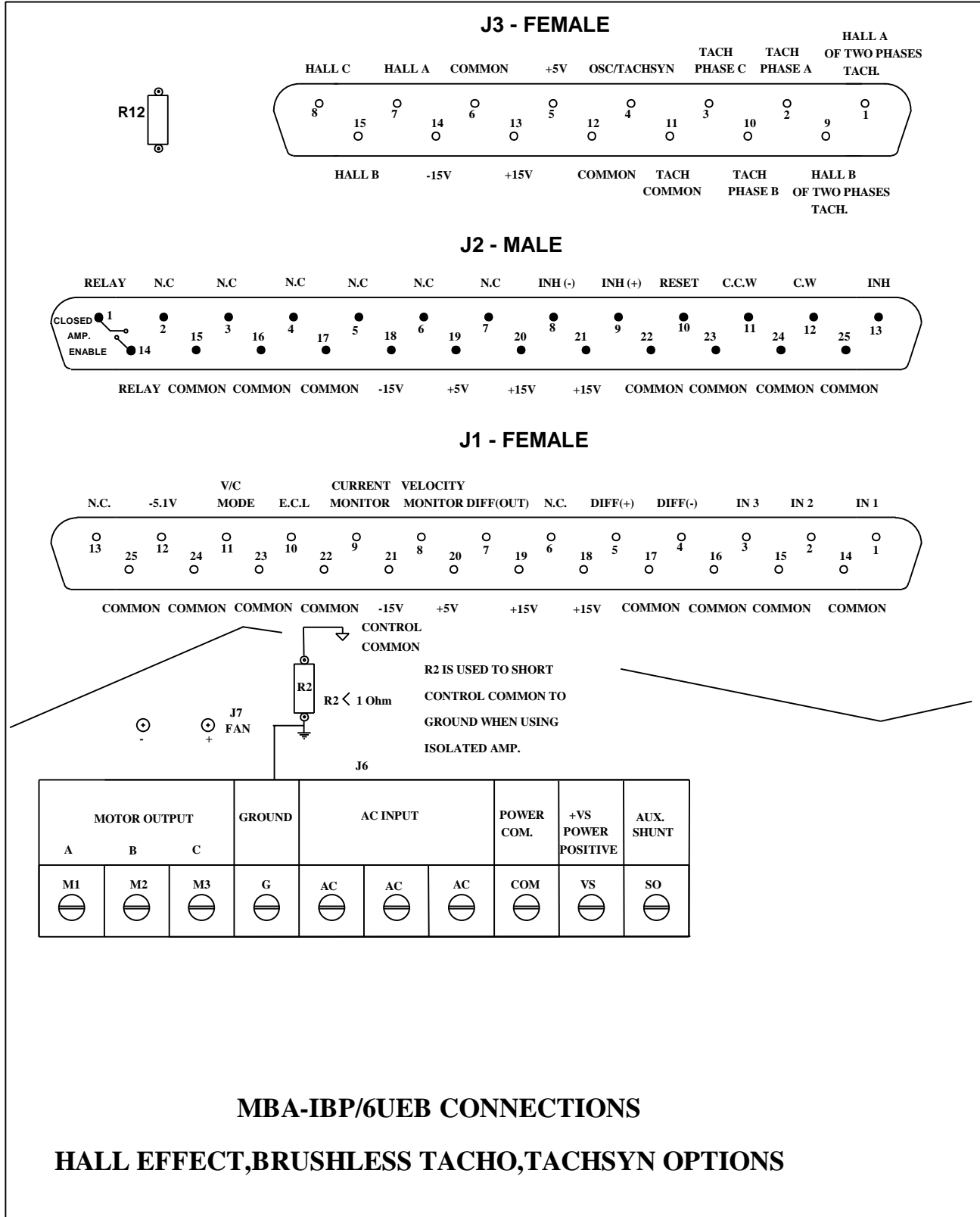

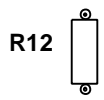

J3 - FEMALE

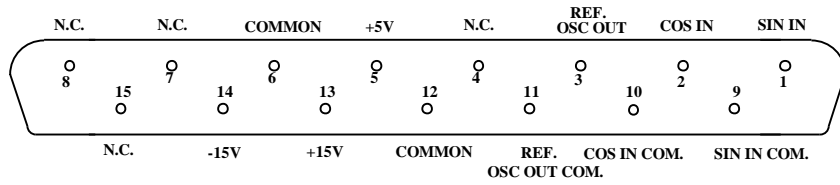

J2 - MALE

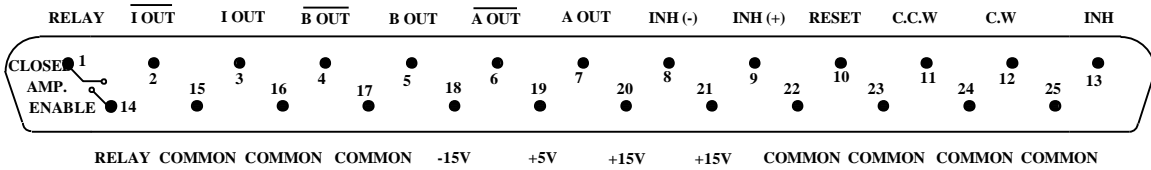

J1 - FEMALE

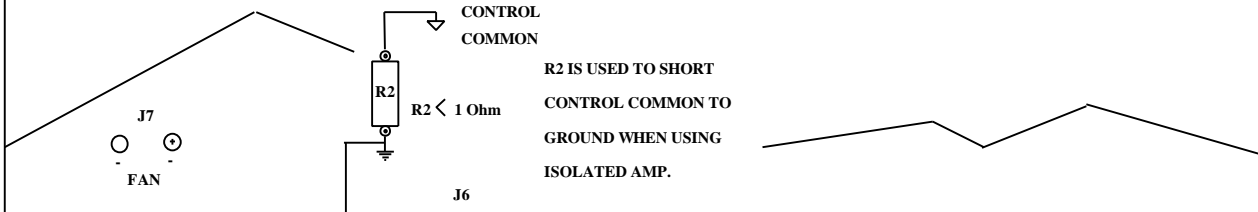
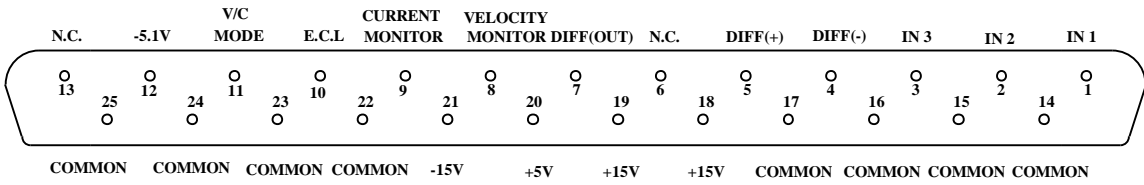

| MOTOR OUTPUT | | | GROUND | AC INPUT | | | POWER COM. | +VS POWER POSITIVE | AUX. SHUNT |
|--------------|----|----|--------|----------|----|----|------------|--------------------|------------|
| A | B | C | | AC | AC | AC | | | |
| M1 | M2 | M3 | G | AC | AC | AC | COM | VS | SO |

MBA-IBP/6UER CONNECTIONS

RESOLVER OPTION

6. Installation procedures

6.1 Mounting

The IBP series dissipates its heat by natural convection except IBPF type which is fan cooled. For optimum dissipation the amplifier should be mounted with the fins vertical.

6.2 Wiring

Proper wiring, grounding and shielding techniques are important in obtaining proper servo operation and performance. Incorrect wiring, grounding or shielding can cause erratic servo performance or even a complete lack of operation.

- a) Keep motor wires as far as possible from the signal level wiring (feedback signals, control signals, etc.).
- b) If additional inductors (chokes) are required, keep the wires between the amplifier and the chokes as short as possible.
- c) Minimize lead lengths as much as is practical. Although the amplifier is protected against long (inductive) supply wires it is recommended to keep the leads as short as possible.
- d) Use twisted and shielded wires for connecting all signals (command and feedback). Avoid running these leads in close proximity to power leads or other sources of EMI noise.
- e) Use a 4 wires twisted and shielded cable for the motor connection.
- f) Shield must be connected at one end only to avoid ground loops.
- g) All grounded components should be tied together at a single point (star connection). This point should then be tied with a single conductor to an earth ground point.
- h) After wiring is completed, carefully inspect all conditions to ensure tightness, good solder joints etc.

A reliable connection with the spring type connectors is achieved with wires of 0.5mm^2 (AWG 20) stripped to a length of 11mm (.43").

6.3 Load inductance

The total load inductance must be sufficient to keep the current ripple within the limits - 50% of the adjusted continuous current limit. The current ripple (I_r) can be calculated by using the following equation:

$$I_r = \frac{0.7 \times V_{ac}}{f \times L} \quad (A)$$

L - load inductance in mH.

Vac - Voltage of the AC supply in Volts.

f - PWM frequency in KHz.

If motor inductance does not exceed this value, 3 chokes should be added (to each motor phase) summing together the required inductance

$$L_{ch} = L - L_p$$

Lch - Choke inductance

Lp - Total inductance between two phases (in Y connection it is the sum of two phases).

6.4 AC power supply

AC power supply can be at any voltage in the range defined within the technical specifications. It must have the capability to deliver power to the amplifier (including peak power), without significant voltage drops. **Any voltage below the minimum or above the maximum will disable the amplifier.**

The recommended AC voltage are:

$$1.2 \times V_{AC}(\min) < V_{AC} < 0.9 \times V_{AC}(\max)$$

Note - Single phase connection:

When using a single phase supply, voltage drop due to loading is expected. The magnitude of the voltage drop depends on the load current, motor velocity, stiffness of the power source and total bus capacitance. It is recommended not to use single phase connection for output current higher than 20A.

For 3U size amplifiers it is recommended to add external capacitance as follows: For 135V units up to 1200 μ F

For 270V units up to 600 μ F

6.5 Wiring diagrams

MOTOR WIRING

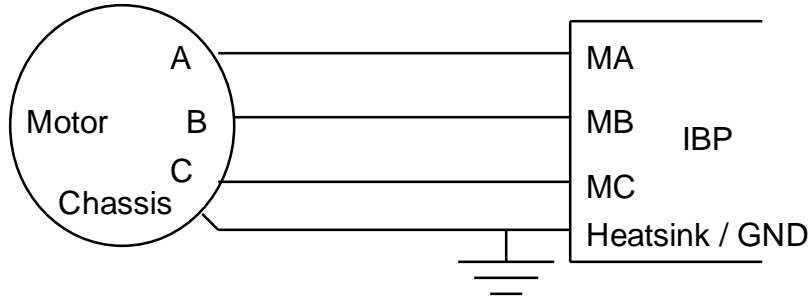

Minimum acceptance

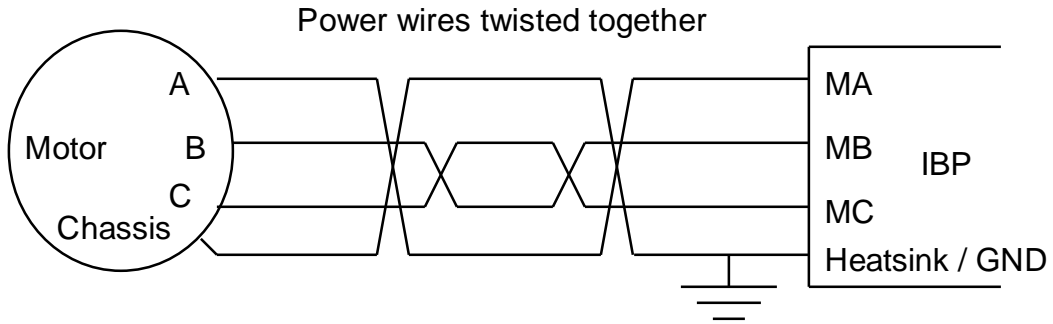
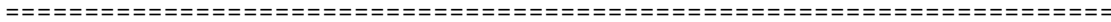

Acceptable for most applications

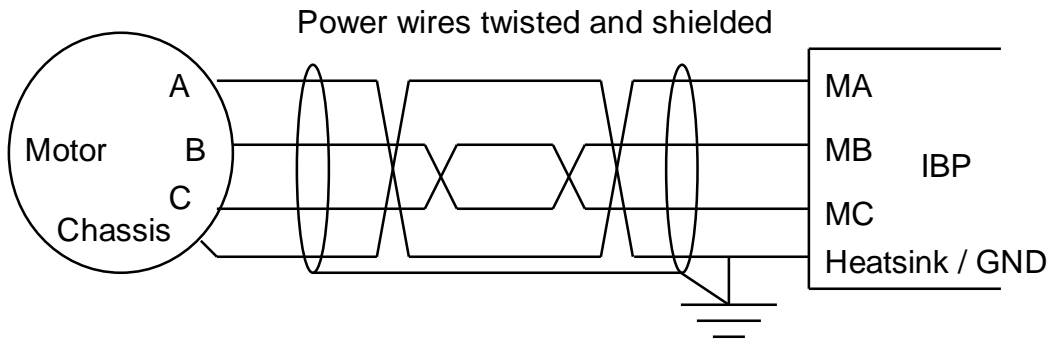
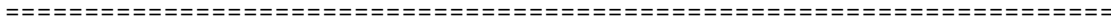

Optimum wiring, minimum RFI

AC POWER WIRING

NON-ISOLATED AC SUPPLIES:

A) DIRECTLY TO THE MAIN

B) USING AUTOTRANSFORMER

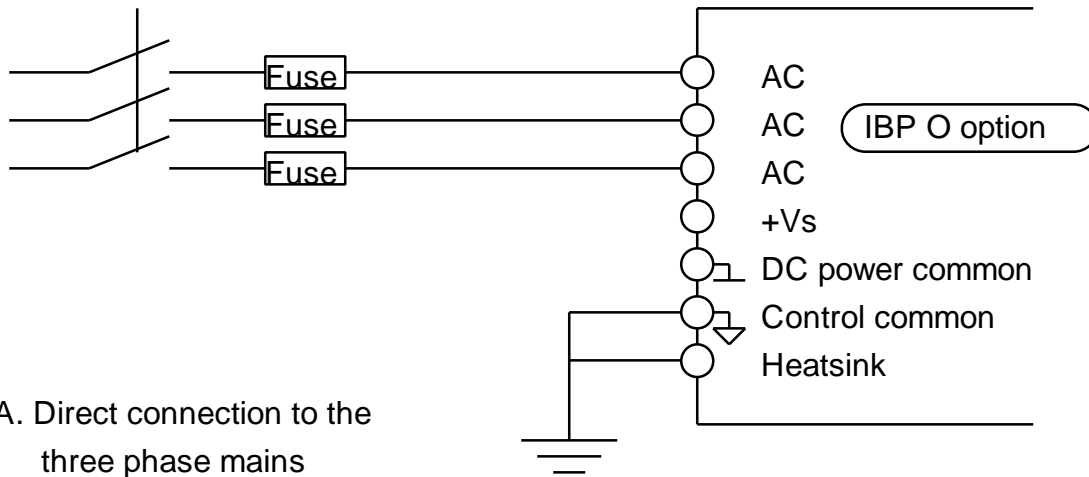

A. Direct connection to the three phase mains

B. External fuses are needed for 3U size only

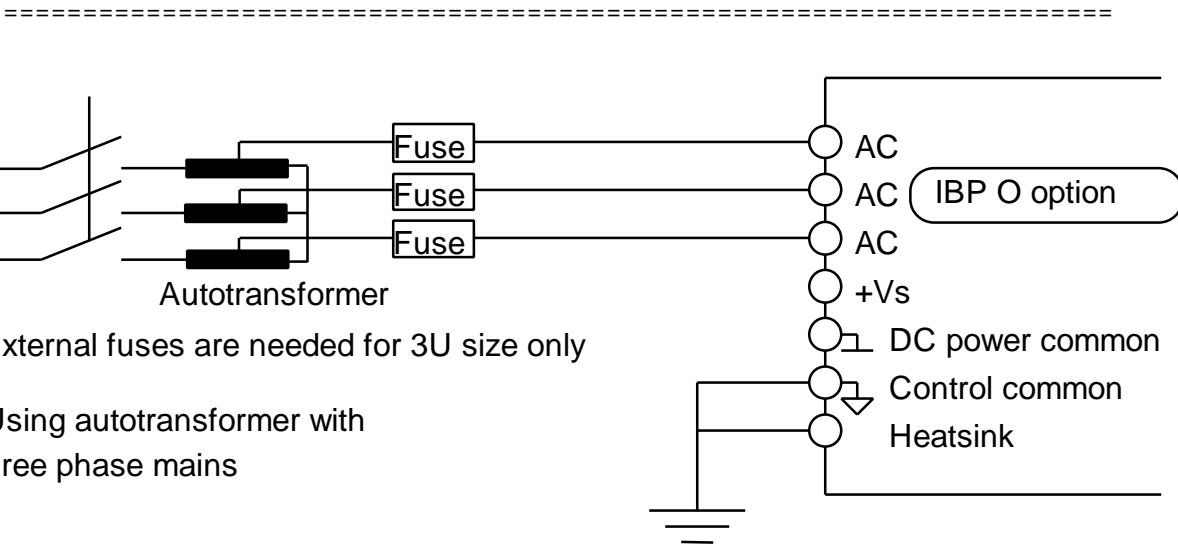

A. External fuses are needed for 3U size only

B. Using autotransformer with three phase mains

Guide lines for connecting non-isolated AC supplies**Ground:**

Control common

Motor chassis

Amplifier's heatsink

Do not ground:

Power common

(The power common is a hot point and any grounding will cause an input rectifier failure).

Caution:

- If source of motor command is grounded, use amplifier's differential input. Otherwise, a ground loop is created.

ISOLATED AC SUPPLIES

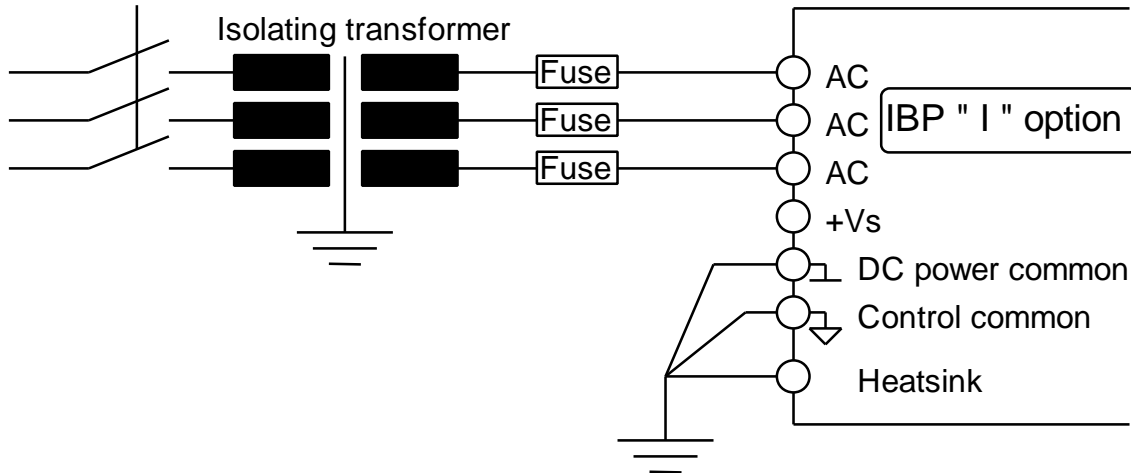

A. External fuses are needed for 3U size only

Guide lines for connecting an Isolated amplifier with an isolating power transformer

Ground:

DC power common

Control common

Motor chassis

Amplifier's heat sink.

Caution:

- If source of motor command is grounded, use amplifier's differential input. Otherwise, a ground loop is created.

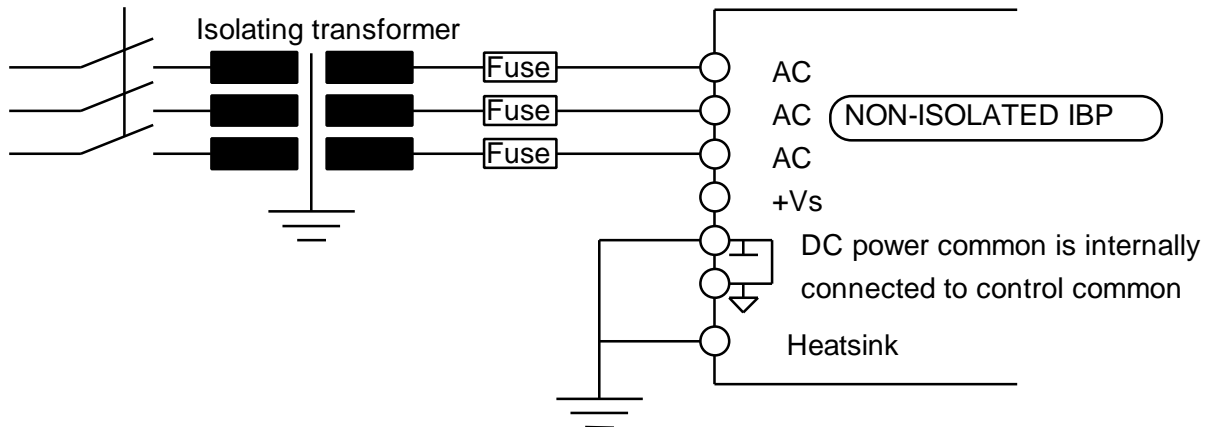

A. External fuses are needed for 3U size only

Guide lines for connecting a non isolated amplifier with an isolating power transformer

Ground:

DC power common
 Motor chassis
 Amplifier's heat sink

Do not ground:

Control common - It is internally connected to the power common. Grounding the control common will create a ground loop.

Caution:

- If source of motor command is grounded, use amplifier's differential input. Otherwise, a ground loop is created.

DIRECT CONNECTION TO THE THREE PHASE MAINS

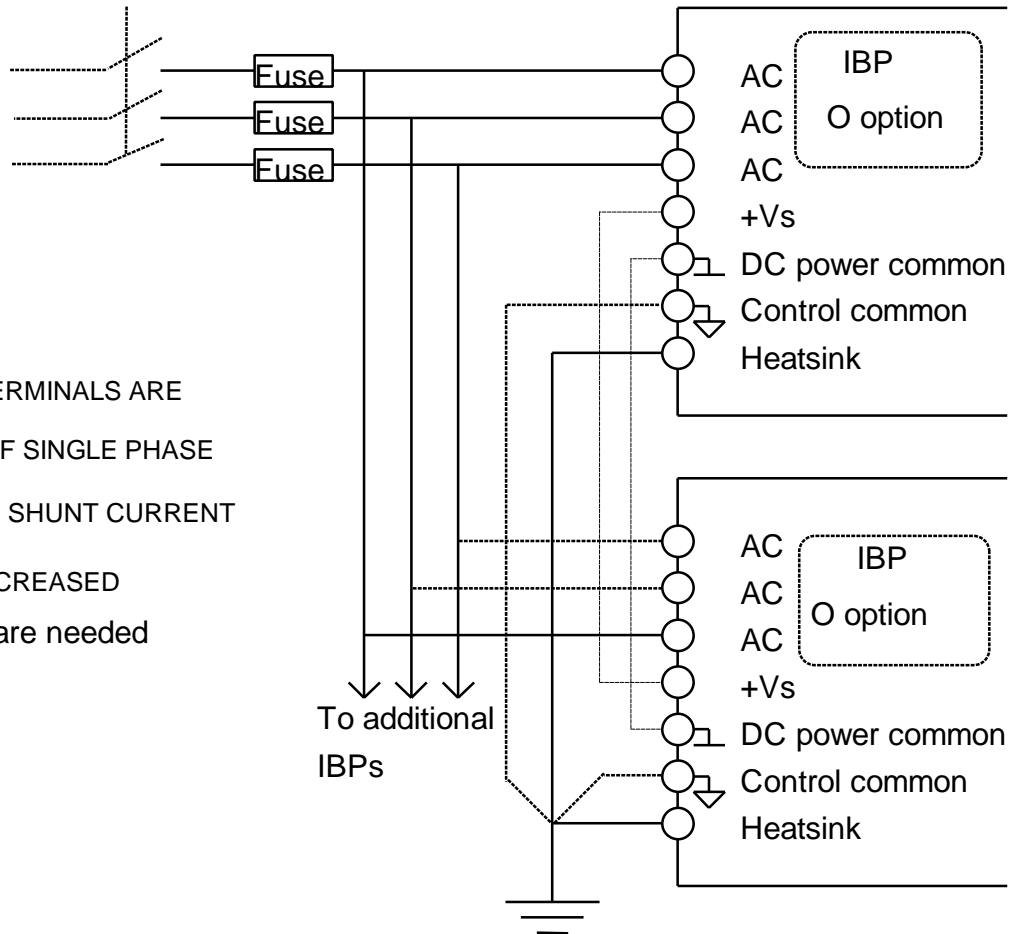

NOTE: DC POWER TERMINALS ARE CONNECTED IF SINGLE PHASE IS USED OR IF SHUNT CURRENT HAS TO BE INCREASED

A. External fuses are needed for 3U size only

CONNECTING MORE THAN ONE IBP

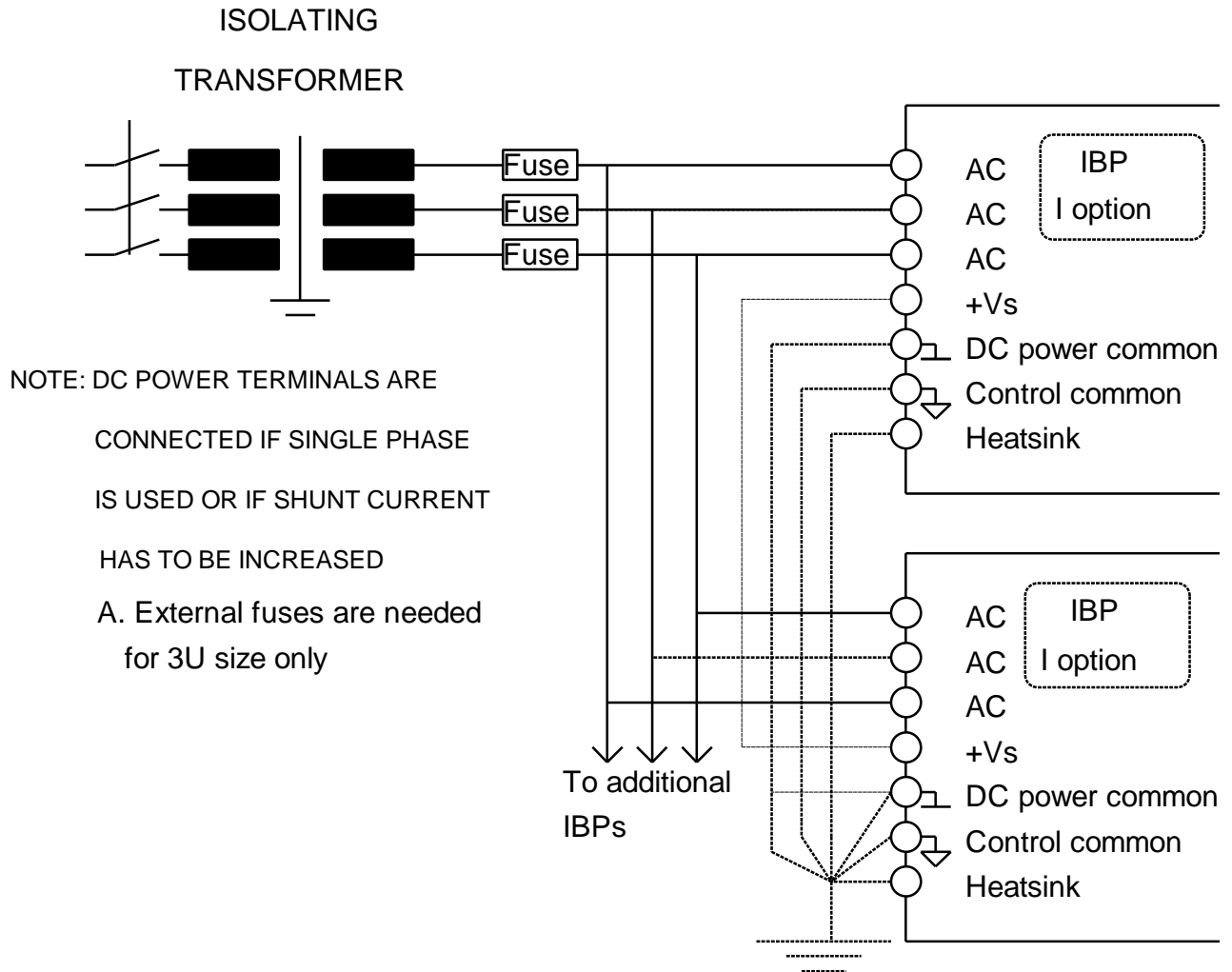

CONNECTING MORE THAN ONE IBP

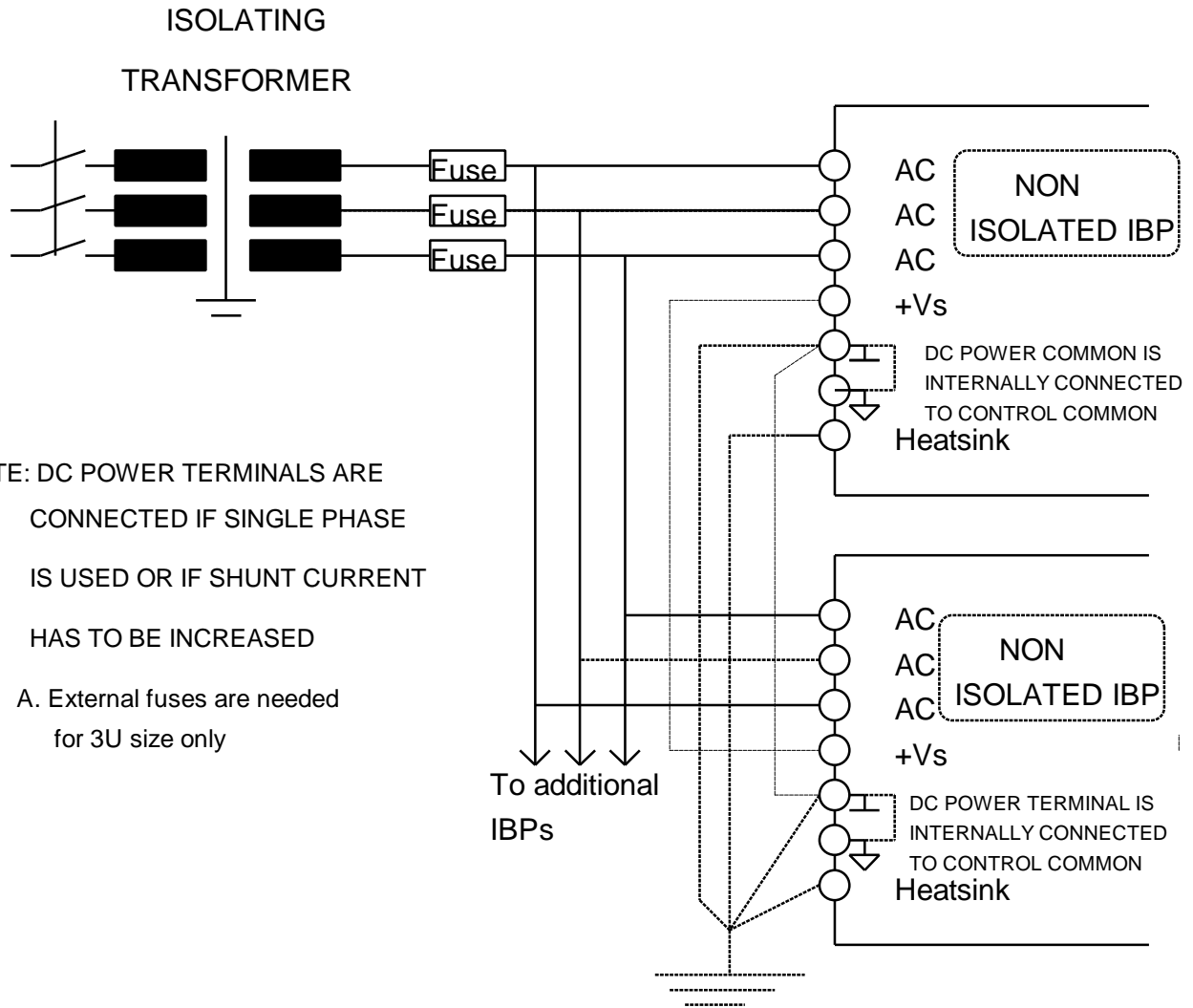

NOTE: DC POWER TERMINALS ARE CONNECTED IF SINGLE PHASE IS USED OR IF SHUNT CURRENT HAS TO BE INCREASED

A. External fuses are needed for 3U size only

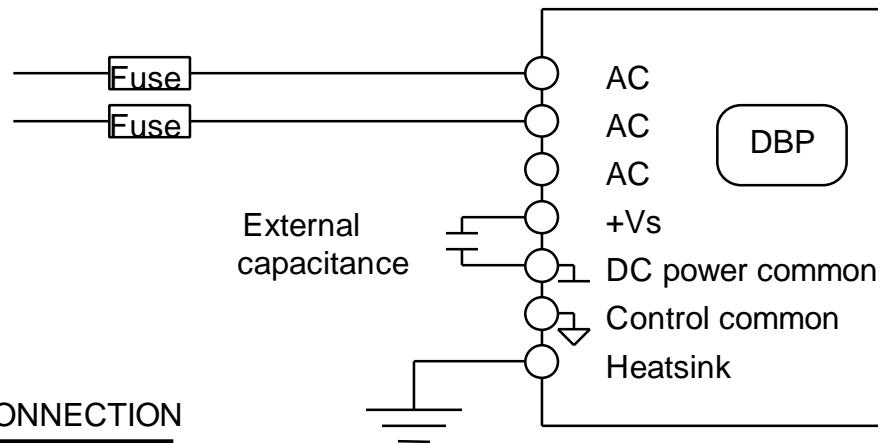

SINGLE PHASE CONNECTION

See chapter 6.4 for details

All rules about supply connections described in the previous pages are also valid for multi-IBP and/or single phase connection.

For 135V types $R_{ex} \geq 9.1\text{ohm}/225\text{Watt}$

For 270V types $R_{ex} \geq 33\text{ohm}/225\text{Watt}$

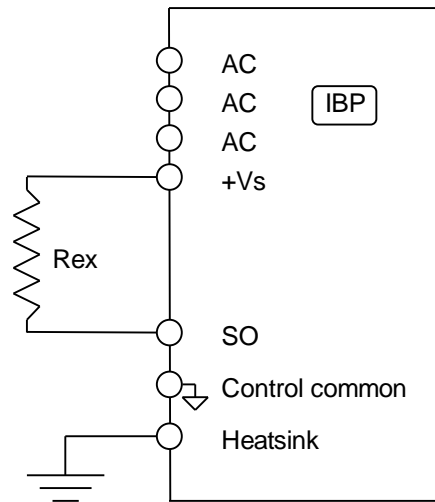

CONNECTING THE EXTERNAL SHUNT RESISTOR DOUBLE EUROCARD SIZE ONLY

CAUTION:

THE RESISTOR IS CONNECTED TO THE DRIVE +VS BUS VOLTAGE. THE WIRES AND THE TERMINALS MUST BE SHIELED FOR SAFETY.

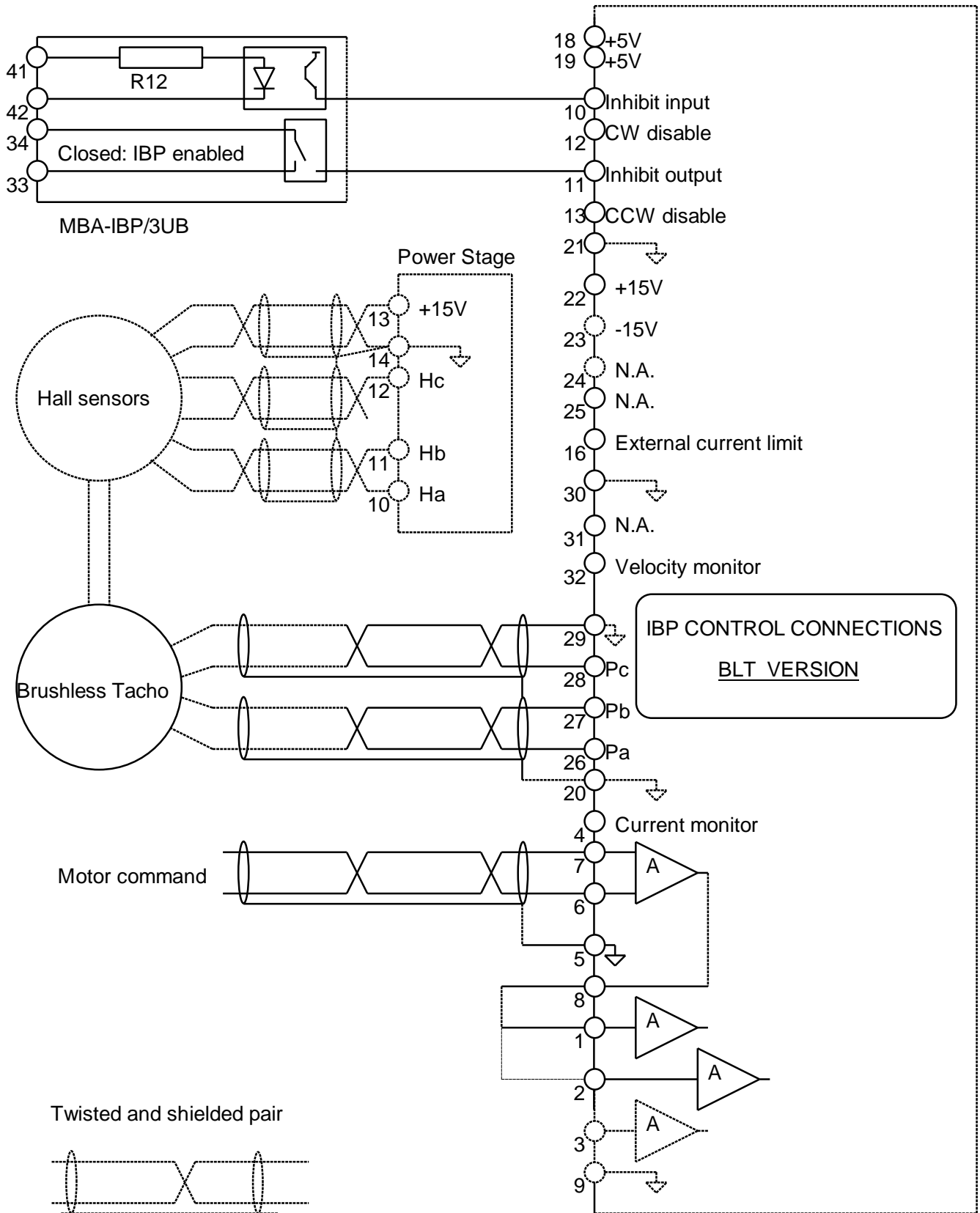

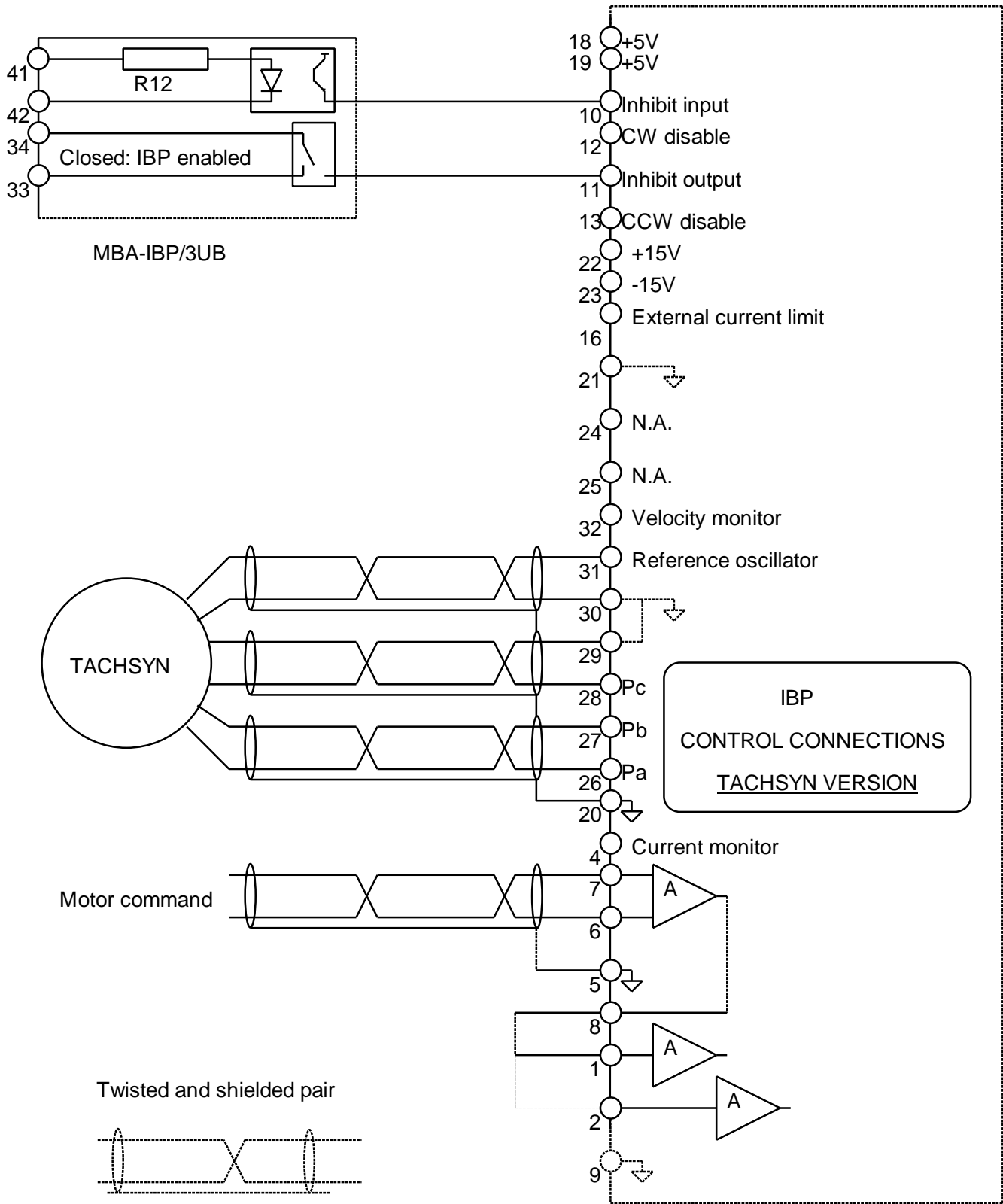

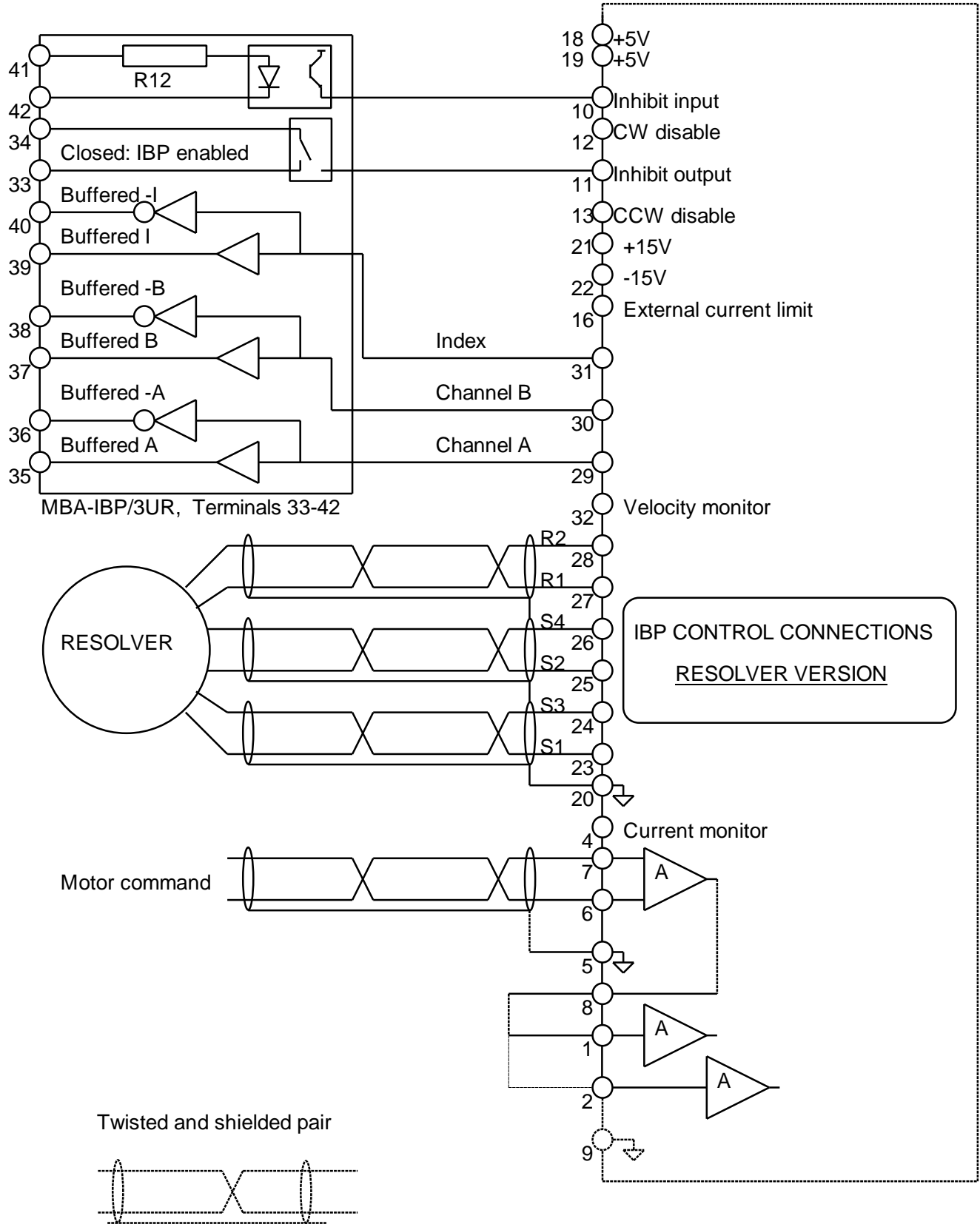

7. Start - Up Procedures

All the operations of this chapter do not require power on the unit. The steps of paragraph 7.1 must be performed before proceeding to the appropriate feedback sensor section.

7.1 Common procedures for all amplifiers types

7.1.1 Commutation signals format

Select the position of DIP switch 1 on the upper board of the power stage according to the commutation signal format of the motor.

| | | |
|----------------|----------------|---------------|
| DS1 positions: | ON (down): 30° | OFF (up): 60° |
|----------------|----------------|---------------|

For all Resolver versions it should be 60°.

7.1.2 CFM function

Select the position of DIP switch 2 on the upper board of the power stage according to the motor's rated current. If it is less than 20% of the amplifier's rated current select:

DS2 to ON (down) - Active CFM

Otherwise,

DS2 to OFF (up) - No CFM

7.1.3 Inhibit and CW/CCW logic

Select the desired Inhibit and CW/CCW logic you need:

- a) Inhibit/CW/CCW functions will be activated by connecting their inputs to a low level signal. If no signal is applied to these inputs the amplifier will be enabled upon power on.

For this logic, R198 (for Inhibit), R199 (for CW), R203 (for CCW) should not be installed.

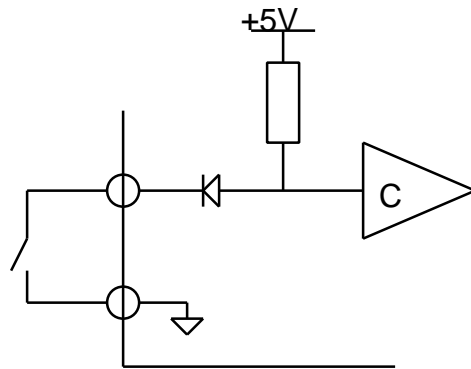

IBP DISABLED BY ACTIVE LOW OR CLOSED CONTACT

$$-1V \leq V_{i1} < 1V$$

$$2V \leq V_{ih} < 30V$$

b) Inhibit/CW/CCW functions will be de-activated by connecting their inputs to a high level signal. If no signal is applied to these inputs the amplifier will be disabled upon power on.

For this logic insert 2Kohm resistors for R198 (Inhibit), R199 (CW), R203 (CCW). The power of these resistors is calculated according to:

$$P_{min} = V^2 / 1500 \quad (\text{Watt})$$

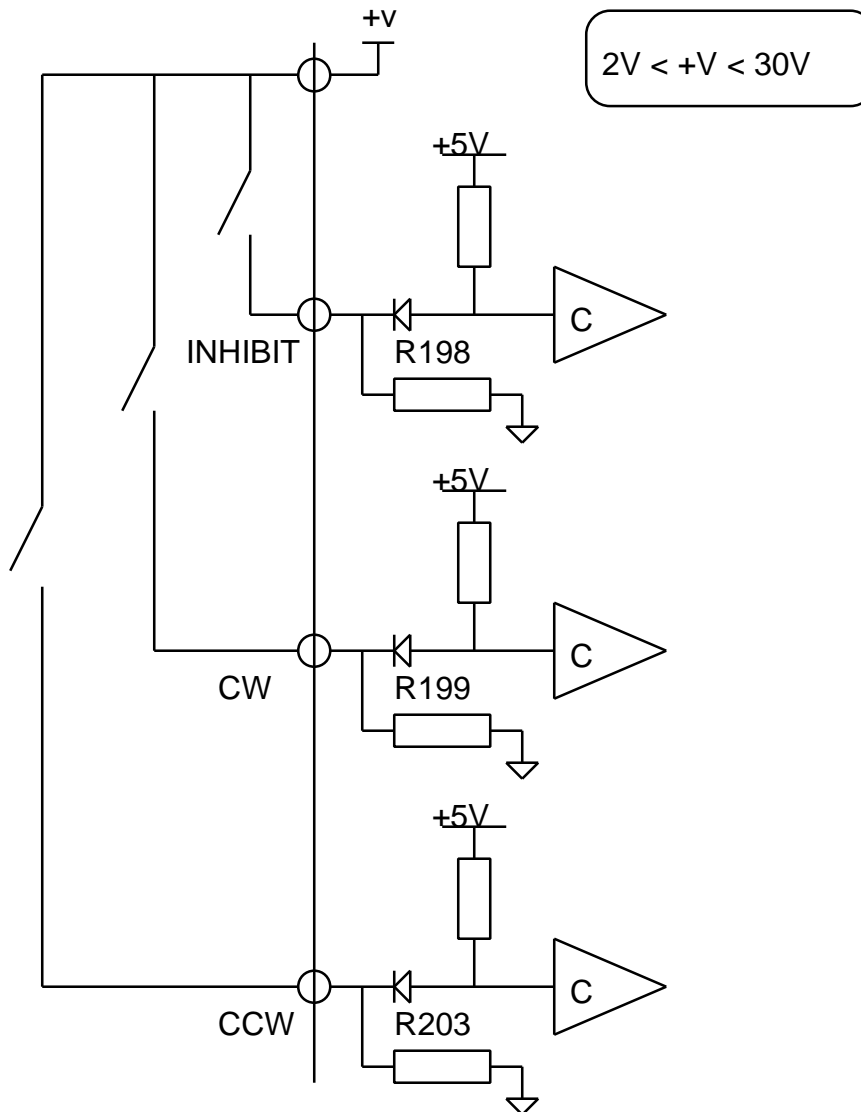

IBP ENABLED BY ACTIVE HIGH OR CLOSED CONTACT

OPTO-ISOLATED INHIBIT

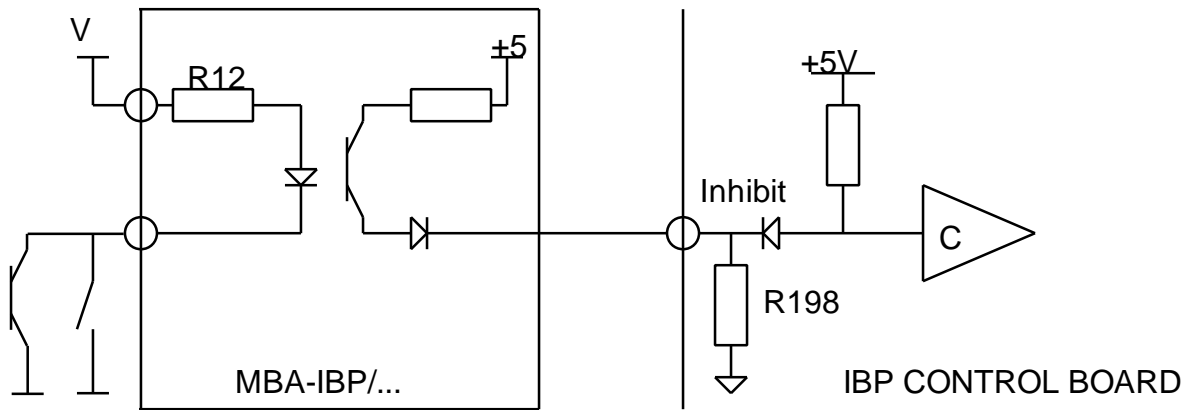

IBP ENABLED BY ACTIVE LOW OR CLOSED CONTACT

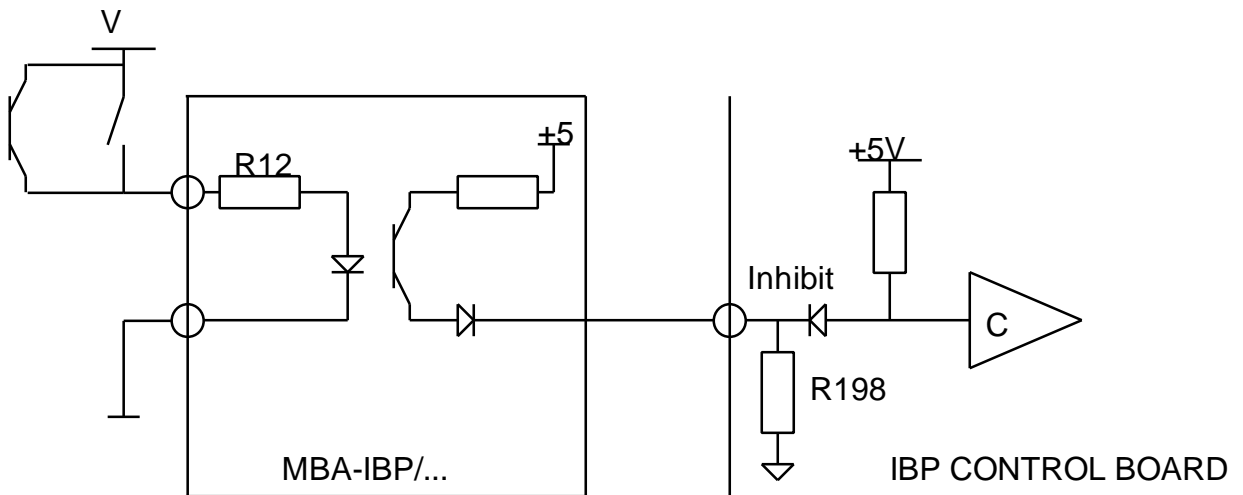

IBP ENABLED BY ACTIVE HIGH OR CLOSED CONTACT

$$R12 = 100 \times V \quad (\text{ohm})$$

V - Voltage at the inhibit input.

Standard value is 2.4K (for 24V). Source must be capable to source or sink 10mA.

7.1.4 Current mode

To operate in current mode the velocity loop should be disabled by converting the error amplifier to a low gain proportional amplifier. This can be done by,

- Turning DS10 to ON,

or

- Connecting terminal H-14,R-20c,E-J1/11 to the circuit common.

In addition, you must make sure that the velocity feedback signal is not entering the error amplifier:

DS14 (for B/T types): OFF

or

DS11 (for resolver types): OFF.

The current limits of the amplifier remain the same as in velocity mode.

7.1.5 Velocity mode

To operate in velocity mode the velocity loop should be enabled by converting the error amplifier to a high gain PI amplifier. This can be done by,

- Turning DS10 to OFF,

or

- Disconnecting terminal H-14,R-20c,E-J1/11 from the circuit common.

In addition, you have to make sure that the velocity feedback signal is entering the error amplifier:

DS14 (for B/T types): ON

or

DS11 (for resolver types): ON.

Make sure that R19,R14 and C5 are installed on the board.

7.1.6 Selecting the reference signal gain

The differential input should be used for the input reference signal. The output of the differential amplifier should be connected to input 1.

Use $R_{80} = R_{81}$, $R_{79} = R_{82}$, $C_{29} = C_{30}$

$$R_{81} = V_{idm} * R_{82} / 10$$

V_{idm} - Max input reference signal fed to the differential inputs

R_{82} is in the range 10K - 100K

C_{29} is in the range 0.01 μ F - 0.47 μ F

R_1 (input 1 resistor) should be 2.49K - standard factory value.

Following are the input maximum voltage and impedance with the standard values of input resistors:

| INPUT RESISTOR | STANDARD VALUE | MAX. VOLTAGE | INPUT IMPEDANCE |
|----------------|----------------|--------------|-----------------|
| 1 - R1 | 2.49 Kohm | 12.5V | 12.5 Kohm |
| 2 - R3 | 15 Kohm | 25V | 25 Kohm |
| 3 - R5 | 1Kohm | 11V | 11 Kohm |

See chapter 4.1 for calculation of other values.

7.1.7 Activating the tacho loss protection (velocity mode only)

Activating the tacho loss protection is done by turning DS6 to ON and inserting R105 and R106 according to the following equations:

$$R_{105} = \frac{20V_p}{V_s} \quad (\text{Kohm})$$

$$R_{106} = \frac{0.85xV_{ac}}{I_{cx}R_m} \times R_{105} \quad (\text{Kohm})$$

V_p - Phase to phase voltage at maximum velocity

Vac - Voltage of AC power supply

Ic - Amplifiers' rated continuous current limit

Rm - Total ohmic resistance of motor (phase to phase plus parasitic resistance)

7.1.8 Latch mode of the protective functions

All the protective functions activate internal inhibit. There are two modes of resetting the amplifier after the cause of the inhibit disappears:

Self Restart (DS9-OFF): The amplifier is inhibited only for the period that the inhibit cause is present. Only in case of the loss of tacho protection, the amplifier is inhibited for 6-8 seconds whenever it does not sense a tacho signal at input 3, and then automatically restarting it. This cycle will continue endlessly but the motor speed will not run away (small movements will be noticed).

Latch (DS9-ON): Each failure latches the Inhibit and the diagnostic LEDs. For restart (after clearing the failure source), reset has to be performed either by turning DS9 to "OFF" or by applying logic 0 at the reset input (H-15,R-18a,E-J2/4), or by turning the power off and on.

| |
|---|
| For safety reason it is recommended to use the amplifier in the LATCH MODE |
|---|

7.1.9 Dynamic contouring of the current limits

If you do not intend to use the dynamic current limits contouring, make sure that:

| |
|------------|
| DS1 is ON |
| DS2 is OFF |
| DS3 is ON |
| DS4 is OFF |

If you want to activate this function, please refer to Appendix B.

7.2 Connecting the feedback elements

7.2.1 Brush Tachogenerator

When using tach feedback, it is recommended to use input 3 for tacho signal. The output leads of the tacho are connected to H-3, R-30a, E-J1/3 and to the circuit common (Negative feedback). The tacho voltage is adjusted by calculating R5 and R87 for two tachogenerator voltages ranges:

For $V_{Tm} > 15V$

$$R5 = 1.33 \times V_{Tm} - 10 \quad (\text{Kohm}), \quad R87 = 20 \text{Kohm}$$

For $V_{Tm} < 15V$

$$R5 = 10 \text{Kohm} \quad R87 = 300 / V_{Tm} \quad (\text{Kohm})$$

V_{Tm} - Voltage generated by tachogenerator at max velocity.

Actual resistor value should be as close as possible to the calculated value.

7.2.2 Brushless Tachogenerator

A) Three Phase Brushless Tachogenerator

Selecting this option is done by arranging the following switches:

| |
|----------------------------|
| DS11 = ON |
| DS12 = OFF |
| DS13 = OFF for 60° sensors |
| or |
| DS13 = ON for 30° sensors |

The three leads should be connected to terminals H-26,R-8c,E-J3/2, H-27,R-6a,E-J3/10, H-28,R-6c,E-J3/3,(phases A,B,C). If the tacho windings are connected in Y (star) and the common connection is available as an output lead, it should be connected to the circuit common. The output of the tacho feedback processor is available at terminal H-32,R-2c,E-J1/8. It can be internally switched to input 3 (H-3,R-30a,E-J1/3) by turning DS14 to ON.

R275,R276 and R277 should be calculated and installed as follows:

| |
|---|
| $R275=R276=R277= 0.332V_{Tm} - 3.32 \quad (\text{Kohm})$ $R5 = 1\text{Kohm}, \quad R87=30\text{Kohm}$ |
|---|

The speed of the motor (N) in RPM is given by:

| |
|---|
| $N = \left(\frac{R275}{3.32} + 1 \right) \times V_{32} / K_{e_{tach}} \quad (\text{R275 in Kohm})$ |
|---|

V_{Tm} - Voltage generated by tachogenerator at max velocity.

$K_{e_{tach}}$ - tacho back EMF constant (Volt/RPM).

V_{32} - voltage at terminal H-32,R-2c,E-J1/8.

B) Two Phase Brushless Tachogenerator

Selecting this option is done by arranging the following switches:

| |
|-----------|
| DS11 = ON |
|-----------|

| |
|-----------|
| DS12 = ON |
|-----------|

Two leads (one from each phase) should be connected to terminals H-26,R-8c,E-J3/2 (phase A) and H-27,R-6a,E-J3/10 (phase B). The other two leads should be connected together to terminal H-29,R-4a,E-J3/11. Its Hall effect sensors should be connected to terminal H-24,R-10c,E-J3/1 (A) and H-25,R-8a,E-J3/9 (B). The output of the tacho feedback processor is available at terminal H-32,R-2c,E-J1/8. It can be internally switched to input 3 (terminal H-3,R-30a,E-J1/3) by turning DS14 to ON. DS13 in ON position will invert the signal polarity. R275 and R276 should be calculated and installed as explained in the previous paragraph (three phase brushless tachogenerator).

7.2.3 Tachsyn

Selecting this option is done by selecting DS11 = OFF. The three phases leads should be connected to terminals H-26,R-8c,E-J3/2, H-27,R-6a,E-J3/10, H-28,R-6c,E-J3/3, (phases A,B,C). The Tachsyn oscillator reference signal is at terminal H-31,R-2a,E-J3/4.

R275,R276 and R277 should be calculated and installed as follows:

| |
|---|
| $R275=R276=R277= 0.332V_{Tc} - 3.32 \text{ (Kohm)}$ |
|---|

| |
|--|
| $R5 = 1\text{Kohm}, \quad R87=30\text{Kohm}$ |
|--|

The speed of the motor (N) in RPM is given by:

$$N = \left(\frac{R275}{3.32} + 1 \right) \times V_{32} / K_{e_{TC}} \quad (\text{R275 in Kohm})$$

V_{TC} - Voltage generated by Tachsyn at max velocity.

$K_{e_{TC}}$ - tachsyn back EMF constant (Volt/RPM).

V_{32} - voltage at terminal H-32,R-2c,E-J1/8.

The output of the velocity processor is available at terminal H-32,R-2c,E-J1/8. It can be internally switched to input 3 (terminal H-3,R-30a,E-J1/3) by turning DS14 to ON.

7.2.4 Resolver

The Resolver interface circuit consists of three basic blocks:

R/D converter

The R/D conversion is done by a variable resolution, monolithic converter type 2S82 of Analog Devices. It accepts two signals from the Resolver (sine and cos.) and converts them into binary position data bits. The resolution of the position bits is user selectable 10, 12, 14 and 16 (only for standard encoder resolution). In addition, the R/D creates a signal that is proportional to the Resolver velocity. This signal is being used as a velocity feedback.

EPROM

The EPROM creates "Hall" signals by mapping the position data bits accepted from R/D into suitable Hall signals to operate a specific BLM. In addition, the encoder index (marker) signal is also produced from the EPROM. The EPROM is designated as follows:

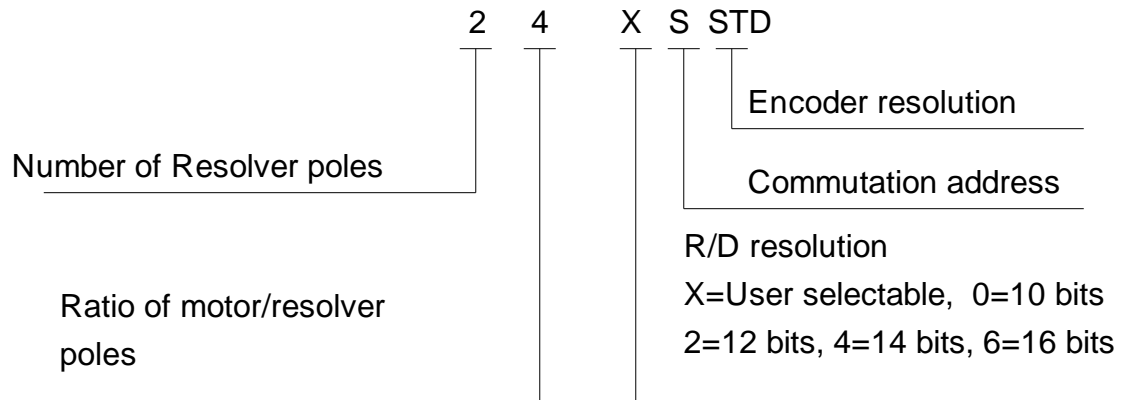

In the S (standard) version zero crossing of phases B C occurs at position address "0" of the Resolver.

Oscillator

Creates sinusoidal waveform signal to excite the primary of the Resolver.

Oscillator Frequency/Amplitude Selection (R228,R233)

The frequency (f_r) and amplitude (V_r) needed to excite the Resolver are taken from the Resolver data sheet.

Selecting the frequency:

$$R228 = 110/f_r \quad (\text{Kohm})$$

$$0.1\text{KHz} < f_r \text{ (KHz)} < 20\text{KHz}$$

Selecting the amplitude:

Take care that the RMS amplitude does not exceed $7V_{rms}$ or that the peak-to-peak (ptp) value is within the range of $2V \leq V_{r_ptp} \leq 20V$.

For Vr in peak-to-peak value:

$$R233 = 6 / (V_r - 2) \quad (\text{Kohm})$$

For Vr in RMS value:

$$R233 = 6 / (2.82V_r - 2) \quad (\text{Kohm})$$

Reference Voltage level to R/D (R192)

In order to adjust the reference voltage input level to $2V_{rms}$, select R192 as follows:

$$R192 = 50 \times (V_{r_{rms}} - 2) \quad (\text{Kohm})$$

For $V_{r_{rms}} < 2V$, install $R192=100$ ohm.

Signal input level (R193,R194)

The R/D inputs ($V_{in_{rms}}$) are adjusted to the sin/cos. Resolver outputs by:

$$\text{Resolver output} = V_{in_{rms}} = V_{r_{rms}} \times \text{Transformation ratio}$$

$$R193 = R194 = V_{in_{rms}} - 2 - R_{stator} \quad (\text{Kohm})$$

(R_{stator} in Kohm).

When $V_{in_{rms}} < 2V$, install $R193=R194=100$ ohm.

The standard R/D converter will not operate for $V_{in_{rms}} < 1.8V$. Consult factory for OEM applications.

Velocity Signal

The tracking converter technique generates an internal signal at the output of the integrator that is proportional to the rate of change of the input angle. This dc analog output (velocity signal) is buffered and represented at terminal H-32,R-2c,E-J1/8. It can be internally connected to terminal H-3,R-30a,E-J1/3 (for closing velocity loop) by turning DS11 to ON.

Max output voltage is $\pm 8V$.

Select maximum actual velocity of the application and calculate the maximum tracking rate T of the Resolver as follows:

$$T = \text{rpm} \times Q / 120$$

T unit is rps: Resolver electrical revolution per second

Q - number of poles of Resolver ;

rpm - mechanical revolution per minute.

Selecting the Resolution

The resolution can be selected to be 10,12,14 or 16 bits by use of DIP switches 13 and 14. When selecting the resolution the rps limits should not be exceeded:

10 bit = 1040 rps

12 bit = 260 rps

14 bit = 65 rps

16 bit = 16.5rps

| Resolution | DS13 | DS14 |
|------------|------|------|
| 10 | ON | ON |
| 12 | ON | OFF |
| 14 | OFF | ON |
| 16 | OFF | OFF |

Note:

- Each resolution change must be followed by new components selection procedure.
- When changing resolution under dynamic conditions, a period of uncertainty will exist before position and velocity data is valid.

Encoder resolution

In the STD mode (DS12 OFF), the encoder signals A,B are created by the EPLD and can have only the following basic resolutions (for 2 pole Resolver):

256 for 10 bits

1024 for 12 bits

4096 for 14 and 16 bits

When the Resolver is more than 2 poles, the resolution for one shaft rotation will be:

$$E_r = Q \times S / 8$$

Q = number of Resolver poles ;

S = resolution of converter (2^{10} , 2^{12} , or 2^{14})

When different encoder resolution is needed the encoder signals are generated by the EPROM and the R/D resolution is no longer user selectable.

This option requires

- DS12 at ON
- Special EPROM which is programmed for this resolution.

HF Filter (R195, R196, C61, C62)

The function of the HF filter is to reduce the amount of noise present on the signal inputs to the 2S82, reaching the Phase Sensitive Detector and affecting the outputs. Values should be chosen so that

$$15\text{Kohm} < R195=R196 < 30\text{Kohm}$$

$$C61 = C62 = \frac{160 \times 10^3}{R195 \times fr} \quad (\text{pF})$$

fr = Reference frequency in KHz

R195 in Kohm

This filter gives an attenuation of 3 times at the input to the phase sensitive detector.

AC Coupling of Reference Input (C60)

Select C60 so that there is no significant phase shift at the reference frequency. That is,

$$C60 = \frac{10^6}{fr(KHz) \times Rx} \quad (pF) \qquad Rx = \frac{100 \times R192}{100 + R192} \quad (Kohm)$$

R192 in Kohm

If Rx yields less than 50K, install a value of Rx=50K in the C60 equation.

Maximum Tracking Rate (R201)

The VCO input resistor R201 sets the maximum tracking rate of the converter and hence the velocity scaling as at the maximum tracking rate, the velocity output will be 8V.

Decide on your required maximum tracking rate, "T" , in Resolver electrical revolutions per second. Note that "T" must not exceed the specified maximum tracking rate or 1/16 of the reference frequency.

$$R201 = 5.92 \times 10^7 / T \times p \quad (Kohm)$$

where p = bit per rev
 = 1,024 for 10 bits resolution
 = 4,096 for 12 bits
 = 16,384 for 14 bits
 = 65,536 for 16 bits

Whenever the actual tracking rate (T) is lower than half of the maximum tracking rate (see "Selecting the Resolution"), R201 should be half of the value calculated above. This improves significantly the low speed performance. In this case the velocity signal at maximum velocity will be +4V.

Closed Loop Bandwidth Selection (C67, C68, R200)

a. Choose the Closed Loop 3dB Bandwidth (f_{bw}) required ensuring that

$$f_{ref} > 10 \times f_{bw}$$

Recommended bandwidth values:

250Hz for 3KHz

300Hz for 5KHz

500Hz for 10KHz

b. Select C67 so that

$$C67 = \frac{2.5 \times 10^9}{R201 \times f_{bw}^2} \quad (\text{pF})$$

with R201 in Kohm and f_{bw} in Hz as selected above.

c. C68 is given by

$$C68 = 40 \times C67 \quad (\text{pF})$$

d. R200 is given by

$$R_{200} = \frac{127 \times 10^7}{f_{bw} \times C_{68}} \quad (\text{Kohm})$$

f_{bw} in Hz, C_{68} in pF

R200 value should be at least three times R197.

Gain Scaling Resistor (R197)

R197 should be installed according the following table:

536Kohm for 10 bits resolution

130Kohm for 12 bits

33Kohm for 14 bits

8.2Kohm for 16 bits

8. Amplifier adjustment

Important remarks:

A. If all the previous steps were accomplished you may now turn the power on and continue with the following adjustments. You may omit the step for current mode or velocity mode according to your application.

B. In some applications, especially those where the motor electrical parameters (total inductance and resistance in the armature circuit) are much smaller or larger than normally encountered, the current loop response should be optimized before proceeding with the following steps - See Appendix A.

8.1 Current limit adjustment

The amplifiers current limits can be adjusted either by the trimmers, or dynamically by an external voltage signal.

Static adjustment

The amplifier current limits can be adjusted without the need for loading using the following procedure:

- a) Turn off the main power.
- b) Turn DS7 to "ON"
 DS8 to "OFF"
 DS6 to "OFF".
- c) Disconnect the motor leads.
- d) Connect a voltmeter between terminal H-4,R-30c,E-J1/9 and the circuit common.
- e) Connect your reference signal to your desired input. The input gain trimmer should be fully CW.
- f) Turn on the power
- g) Apply the maximum reference voltage to cause an error at the error amplifier.

In order to adjust the continuous limit, the peak limit should be lower than the continuous limit

- h) Turn T6 (Ip) CCW. At the point when peak limit=continuous limit, the meter readout will stop decreasing. Turn 4-6 turns more.

- i) Using T7 (Ic), adjust the continuous limit by monitoring the meter readout (See equation for current monitor scaling). Full CW rotation will result in type current limit.
- j) After adjusting the continuous limit, readjust T6 up to the desired peak level.

| | | |
|------------------------|------|-----|
| | 10 | |
| Current monitor scale: | ---- | V/A |
| | Ip | |

- k) Reset DS6,DS7,DS8 as required.

Dynamic adjustment- External Current Limit (ECL)

The ECL signal (0-8V) scales down the current limits as selected in the static adjustment. Activating the ECL is done by turning DS5 to "OFF". In addition, the following must be done:

| | |
|-------------------------------|-------------------------|
| - ECL on cont. current limit: | DS1 - "OFF", DS2 - "ON" |
| - ECL on peak current limit: | DS3 - "OFF", DS4 - "ON" |

The ECL can function on either or both current limits and in conjunction with contour adjustment - priority to the lowest value.

8.2 Balance adjustment

If the motor is rotating with the command signal at zero voltage, a balance adjustment will be necessary. Turn the balance trimmer (T4) as required until the motor stops. As a rule, have the command signal connected and set to zero when balancing the amplifier. This way, any offset in the command signal will be canceled. If the balance trimmer has insufficient range, a lower value of resistance can be substituted for R10 to obtain a wider adjustment range.

8.3 Current gain adjustment (for current mode only)

- a) Disconnect motors leads.
- b) Turn DS7 to ON and DS8 to OFF.
- c) Apply voltage to the desired input and read the current monitor output at terminal H-4,R-30c,E-J1/9. Adjust the input gain trimmer until the desired gain is achieved. The current gain (A/V) is given by:

$$G_c = \frac{\text{Current monitor voltage}}{V_{in} \times \text{Current monitor scale}}$$

8.4 Adjusting the motor speed (velocity mode only)

Adjusting the speed is done by using the input gain trimmers (either the command or tacho feedback).

- Increasing/decreasing the feedback gain will decrease/increase the speed.
- Increasing/decreasing the command gain will increase/decrease the speed.

8.5 Response adjustment (velocity mode only)

In most applications optimum response is achieved by adjusting the compensation (COMP) trimmer. Adjustment procedure is as follows:

- Provide the amplifier with a low frequency, bi-directional square wave velocity command (A 0.5Hz, +2.0V waveform is often employed).
- Apply power to the amplifier, and while monitoring the tachometer signal, gradually adjust the COMP trimmer from the CW toward the CCW position. Optimum response (critically-damped) should be achieved at some position before reaching full CCW on T5. Fig 8.1 illustrates the types of waveforms observed for various setting of T5.

In some applications, especially those where the load inertia is much smaller or larger than normally encountered, the standard compensation components values of 0.1 μ F for C5 and 470Kohm for R14 may not allow an optimum setting of the COMP trimmer T5. In fact, the velocity loop may be unstable for any setting of T5. In these cases different values for C5 and R14 must be chosen. The following procedure can be used to select these values:

- Short circuit C5 with a short jumper wire.

- Replace R14 with a decade resistance box. Initially set the box resistance at 20Kohm.
- Set T5, the COMP trimmer to approximately midrange.
- Input a 0.5Hz, 2V bi-directional square wave velocity command signal to the amplifier.
- Apply power, and while monitoring the tachometer signal, gradually increase the value of the resistance box until optimum response as depicted in Fig 8.1 is achieved.
- Substitute the closest standard value discrete resistor for R14 and remove the decade resistance box.
- Remove the shorting jumper across C5, and again check the response using the squarewave test signal. If near optimum results are obtained, trim the response using COMP trimmer-T5 for the optimum.
- If the previous step does not yield satisfactory results, if unacceptable overshooting has been noted, substitute a larger value than 0.047 μ F; or, if the response is overdamped substitute a smaller value than 0.047 μ F. Repetition of this procedure should yield an optimum choice for C5.
- Finally, select a new value of C6 so that the time constant of R14xC6 remains approx. as it was with the standard value of R14.

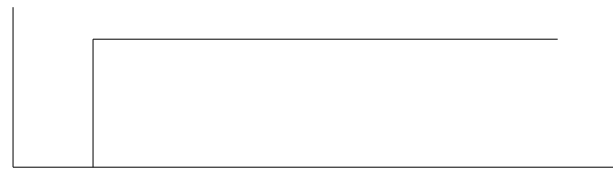

Reference input signal

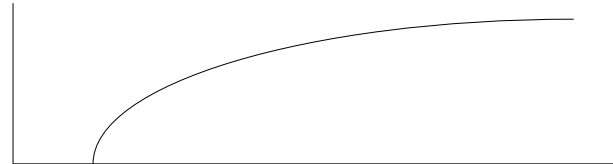

Overdamped: T5 too far CW

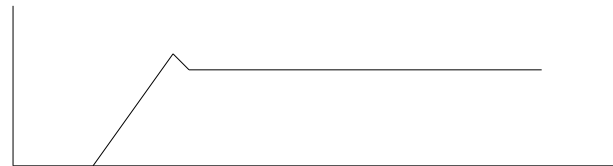

Critically damped: T5 optimum

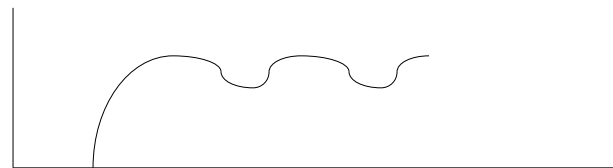

Underdamped: T5 too far CCW

Fig. 8.1

Typical velocity response waveforms

9. Tables and Summaries

9.1 Adjusting trimmers

Seven trimmers are installed on the upper board of the amplifier with the following functions:

| | |
|------------|---|
| T1-Gain 1 | CW rotation increases input 1 gain (H-1,R-32a,E-J1/1) |
| T2-Gain 2 | CW rotation increases input 2 gain (H-2,R-32c,E-J1/2) |
| T3-Gain 3 | CW rotation increases input 3 gain (H-3,R-30a,E-J1/3) |
| T4-Balance | See 8.1. |
| T5-Comp. | AC gain compensation in the velocity loop (see 8.5). |
| T6- I_p | CW rotation increases peak current limit (see 8.2). |
| T7- I_c | CW rotation increases continuous current limit (see 8.2). |

9.2 LED diagnostics

Five LEDs are installed on the upper board of the amplifier with the following designations: I_c , Sh , In , Pr , V_s . Under normal operation only V_s should illuminate (V_s indicates the existence of supply voltages). The following table represents all the combinations possibilities of the LEDs (X - Illuminated LED):

| LED | 1 | 2 | 3 | 4 | 5 | 6 | 7 | 8 |
|-------|---|---|---|---|---|---|---|---|
| I_c | | | | X | X | | | X |
| Sh | | | X | | | X | | X |
| In | X | X | X | | X | X | X | X |
| Pr | | X | | | | X | | X |
| V_s | X | X | X | X | X | X | | X |

1. External inhibit.
2. Under / over voltage protection.
3. Short protection.
4. Continuous current limit.
5. Insufficient load inductance or loss of tacho feedback.
6. Excess temperature.
7. Internal power supply is loaded (Either internally or externally)
8. Loss of commutation feed back.

9.3 Summary of DIP switches

Power stage board

(2 poles DIP switch)

| DIP switch | OFF (UP) | ON (DOWN) |
|------------|--------------------------------|--------------------------------|
| DS1 | 60° commutation signals format | 30° commutation signals format |
| DS2 | No CFM | Activate CFM |

Control stage board

(10 poles DIP switch)

| DIP switch | OFF | ON |
|------------|---------------------------|------------------------------------|
| DS1 | Ic contouring (DS2 ON) | No contouring Ic (DS2 OFF) |
| DS2 | No contouring Ic (DS1 ON) | Ic contouring (DS1 OFF) |
| DS3 | Ip contouring (DS4 ON) | No contouring Ip (DS4 OFF) |
| DS4 | No contouring Ip (DS3 ON) | Ip contouring (DS OFF) |
| DS5 | Enable ECL | Disable ECL |
| DS6 | Disable "Loss of Tach" | "Loss of Tach" activated |
| DS7 | | Current command monitor (DS8 OFF) |
| DS8 | | Current feedback monitor (DS7 OFF) |
| DS9 | Non latch mode | Latch mode for protections |
| DS10 | Velocity mode | Current mode |

4 poles DIP switch (for velocity sensors other than Resolver)

| Switch | OFF | ON |
|--------|------------------------------------|-------------------------------------|
| DS11 | Tachsyn | Brushless Tacho |
| DS12 | 3 phase brushless tacho | 2 phase brushless tacho |
| DS13 | 60° commutation signal format or * | 30° commutation signal format or ** |
| DS14 | Tacho signal disconnected | Tacho signal connected to input 3. |

* non-inverting in case of two phase brushless tacho.

** inverting in case of two phase brushless tacho.

4 poles DIP switch (for Resolver)

| Switch | OFF | ON |
|--------|---|---|
| DS11 | Tacho signal disconnected | Tacho signal connected to input 3. |
| DS12 | Standard encoder resolution | Non-standard encoder resolution |
| DS13 | 14 bit resolution (DS14-ON) 16 bit resolution (DS14-OFF) | 10 bit resolution (DS14-ON) 12 bit resolution (DS14-OFF) |
| DS14 | 12 bit resolution (DS13-ON) 16 bit resolution (DS13-OFF) | 10 bit resolution (DS13-ON) 14 bit resolution (DS13-OFF) |

Appendix A - Current gain and response

In most applications it is not necessary to adjust the current loop to achieve the optimum response. When there are extreme electrical parameters in the armature circuit (inductance and resistance) the standard components values of 0.01 μ F for C8 and 100Kohm for R33 may not yield with the optimum response. The current loop should be optimized as follows:

- Turn the amplifier to a current amplifier by turning DS10 to ON.
- Provide the amplifier with a bi-directional square wave current command (100-200Hz, +2.0V waveform is often employed).
- Apply power to the amplifier, and monitor the load current either by a current probe or by the current monitor. For this application DS7 and DS8 should be arranged as follows:

| |
|-----------------------|
| DS7 = OFF DS8 = ON |
|-----------------------|

If the current response is not critically damped, use the following procedure:

- Short circuit C8 with a short jumper wire.
- Replace R33 with a decade resistance box. Initially set the box resistance at 10Kohm.
- Apply the square wave test signal to the amplifier input.
- Apply power, and while monitoring the load current, gradually increase the value of the box resistance until optimum response as depicted in Fig A-1 is achieved.
- Substitute the closest standard value discrete resistor for R33 and remove the decade resistance box.
- Remove the shorting jumper across C8, and again check the response using the square wave test signal.
- If the previous step does not yield satisfactory results, if unacceptable overshooting has been noted, substitute a larger value than 0.01 μ F; or, if the response is overdamped, substitute a smaller value than 0.01 μ F. Repetition of this procedure should yield an optimum choice for C8.

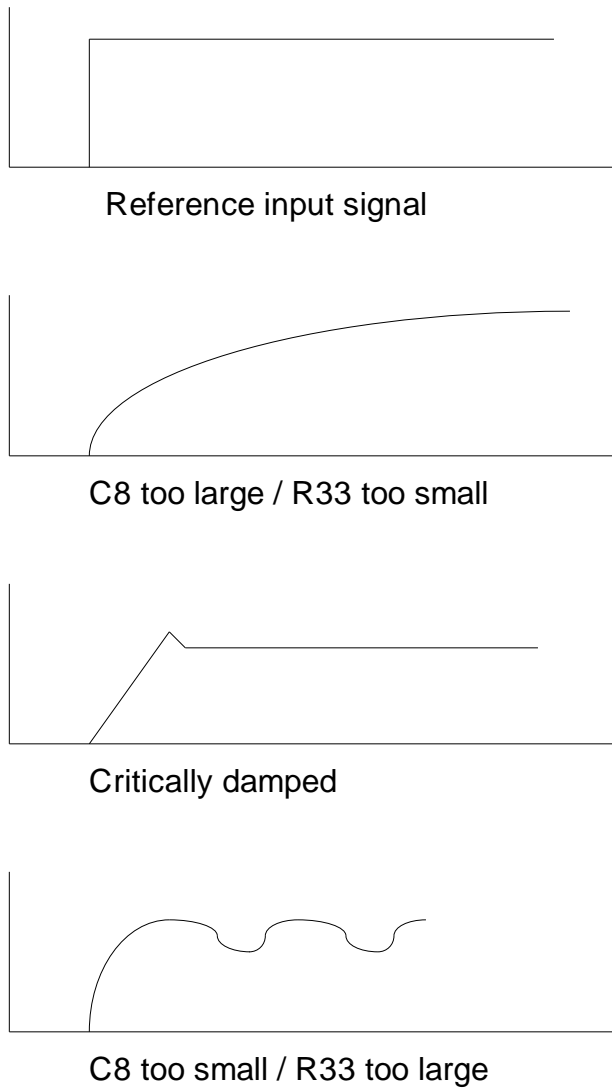

Fig. A-1

Typical current response waveforms

Appendix B - Current limits contour adjustment

The amplifier can be configured to have either continuous current limit or peak current limit or both which depend on motor velocity. This function will work only when using a velocity feedback.

The continuous current limit is speed dependent when:

| | |
|-------------|------------|
| DS1 - "OFF" | DS2 - "ON" |
|-------------|------------|

The peak current limit is speed dependent when:

| | |
|-------------|------------|
| DS3 - "OFF" | DS4 - "ON" |
|-------------|------------|

The general shape of the operating envelope is given in fig. B-1.

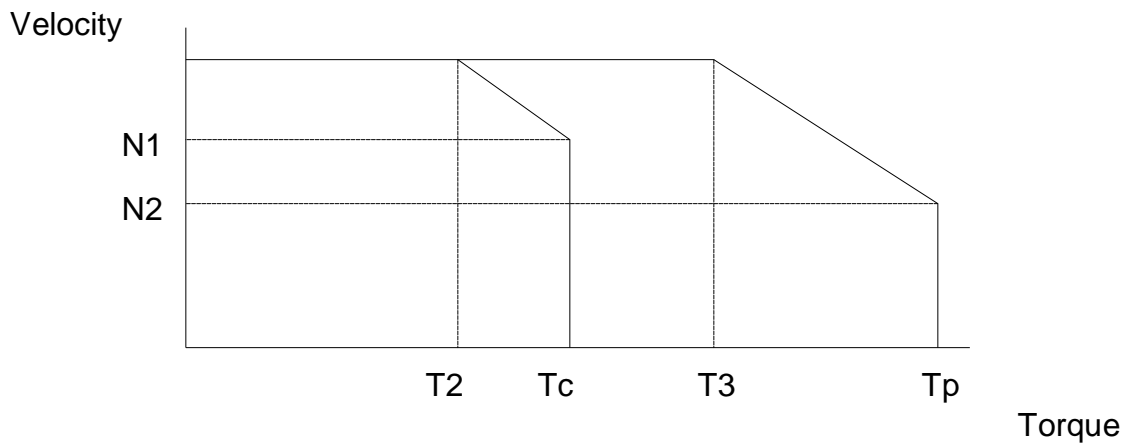

T_c - Max continuous torque up to velocity N_1

T_2 - Continuous torque at max velocity (N_{max}).

T_p - Max peak torque up to velocity N_2 .

T_3 - Peak torque at maximum velocity.

Fig. B-1: Current limits contour

The user should derive the relations $r_1=N_1/N_{max}$, $r_2=T_2/T_c$, $s_1=N_2/N_{max}$ and $s_2=T_3/T_p$ from the motor data sheet. R88 and R89

(for cont. limit) and/or R186/R187 (for peak limit) should be installed according to the following relations:

Continuous current limit contouring:

$$R88=100 \frac{1 - r1}{1 - r2} \quad (\text{Kohm})$$

$$R89=66 \frac{R88}{R88 + 100r1} \quad (\text{Kohm})$$

Peak current limit contouring:

$$R186=100 \frac{1 - s1}{1 - s2} \quad (\text{Kohm})$$

$$R187=66 \frac{R186}{R186 + 100s1} \quad (\text{Kohm})$$

Important notice: within the pairs DS1/2 and DS3/4, the switches must be always in opposite positions. This means, for example, that if DS1 is ON, DS2 must be OFF and if DS1 is OFF, DS2 must be ON.

Appendix C - Differential amplifier connection

The differential amplifier is provided for your optional use. It can be used for buffering, inverting or elimination of common mode signals.

The differential amplifier inputs are available at terminals H-6,R-28c,E-J1/4 ,H-7,R-26a,E-J1/5. Terminal H-6,R-28c,E-J1/4 is the inverting input, terminal H-7,R-26a,E-J1/5 is the non-inverting input. The output is on terminal H-8,R-26c,E-J1/7, and is to be connected to an available input terminal. The differential amplifier is not internally connected to the summing junction.

The differential amplifier may be used as a buffer or as an eliminator of common mode signals. For a non-inverting buffer amplifier, connect the positive signal lead to terminal H-7,R-26a,E-J1/5 and the negative signal lead to terminal H-6,R-28c,E-J1/4, and connect terminal H-6,R-28c,E-J1/4 to the circuit common. For an inverting buffer amplifier, connect the positive signal lead to terminal H-6,R-28c,E-J1/4, the negative signal lead to terminal H-7,R-26a,E-J1/5, and connect terminal H-7,R-26a,E-J1/5 to the circuit common. The output of the differential amplifier is given by:

$$V_O = \frac{V_7 \times R79}{R79 + R80} \times \left(1 + \frac{R82}{R81} \right) - \frac{V_6 \times R82}{R81}$$

V_7 - Input voltage of terminal H-7,R-26a,E-J1/5.

V_6 - Input voltage of terminal H-6,R-28c,E-J1/4.

$$V_{7\max} \leq \frac{10 \times (R79 + R80)}{R79}; \quad V_{6\max} \leq \frac{10 \times R82}{R81}$$

See schematic in chapter 4.

DIMENSIONAL DRAWINGS

IN THE FOLLOWING DRAWINGS ALL THE DIMENSIONS ARE IN MILLIMETERS.

PANEL (H), BP1

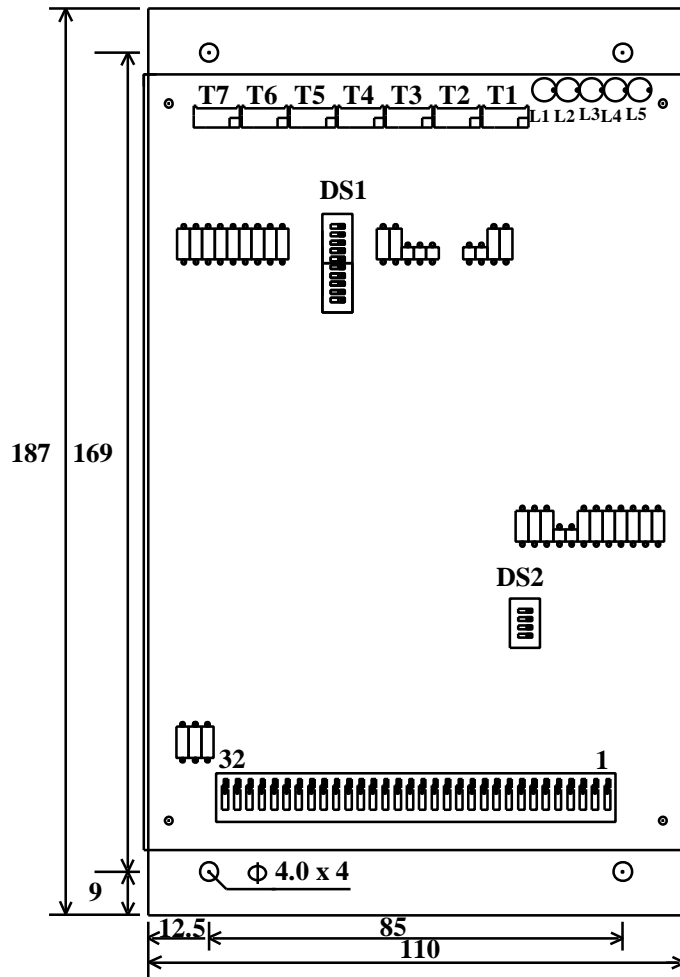

BP1 - TOP VIEW

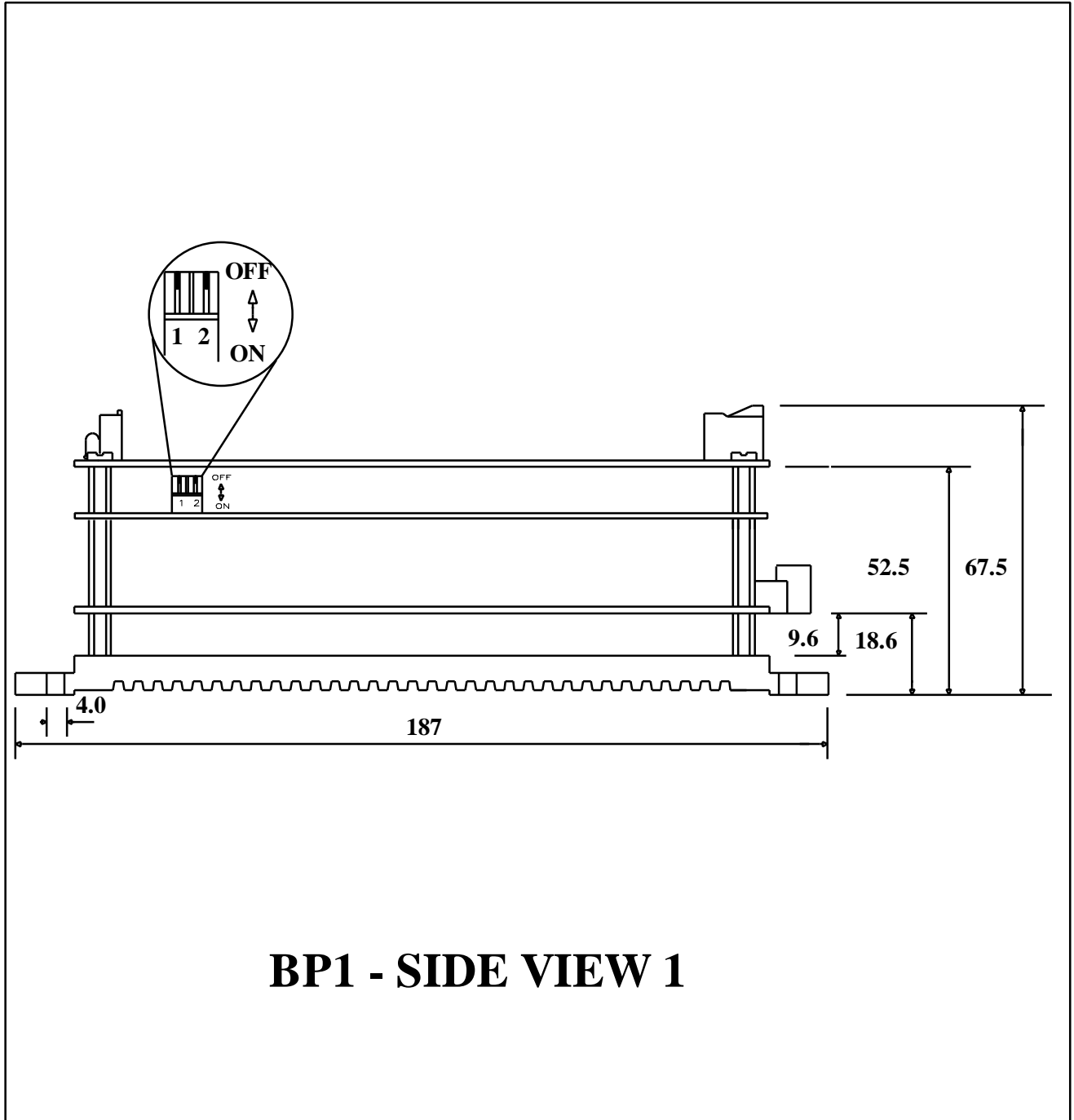

BP1 - SIDE VIEW 1

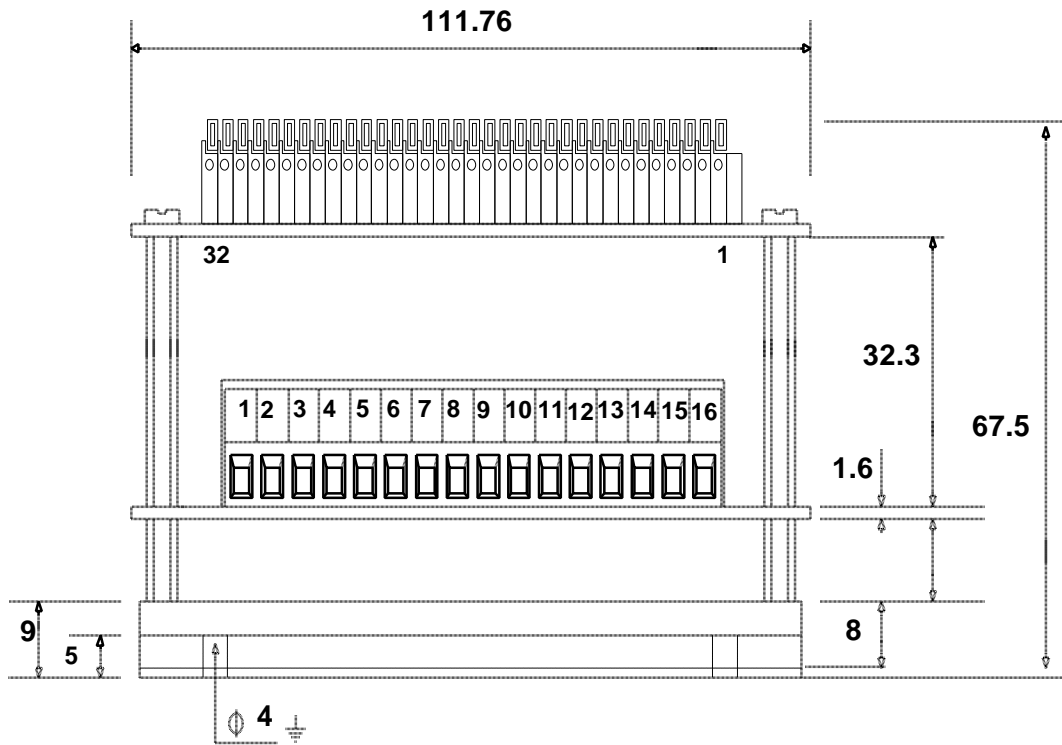

BP1 - SIDE VIEW 2

PANEL (H), BP2

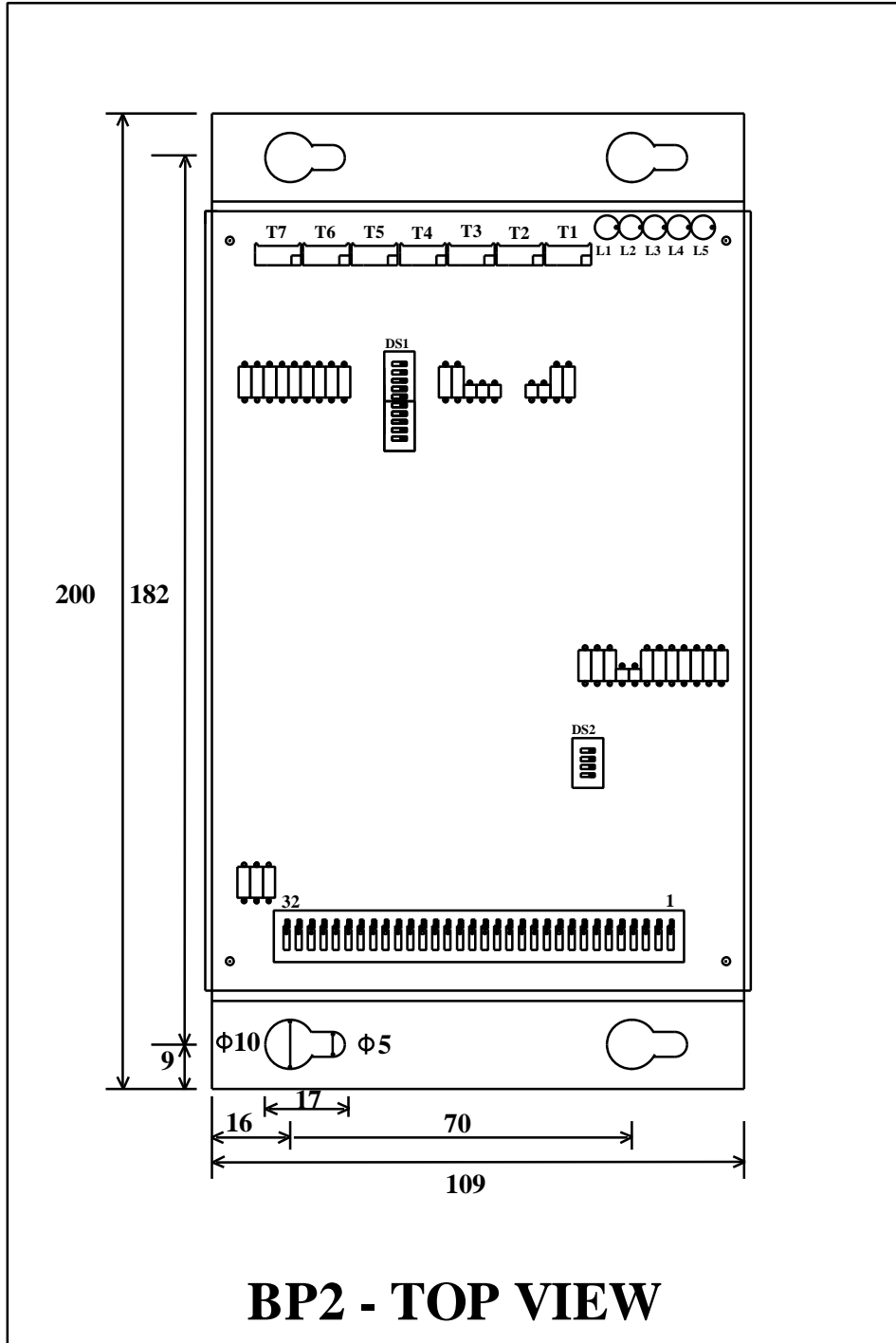

BP2 - TOP VIEW

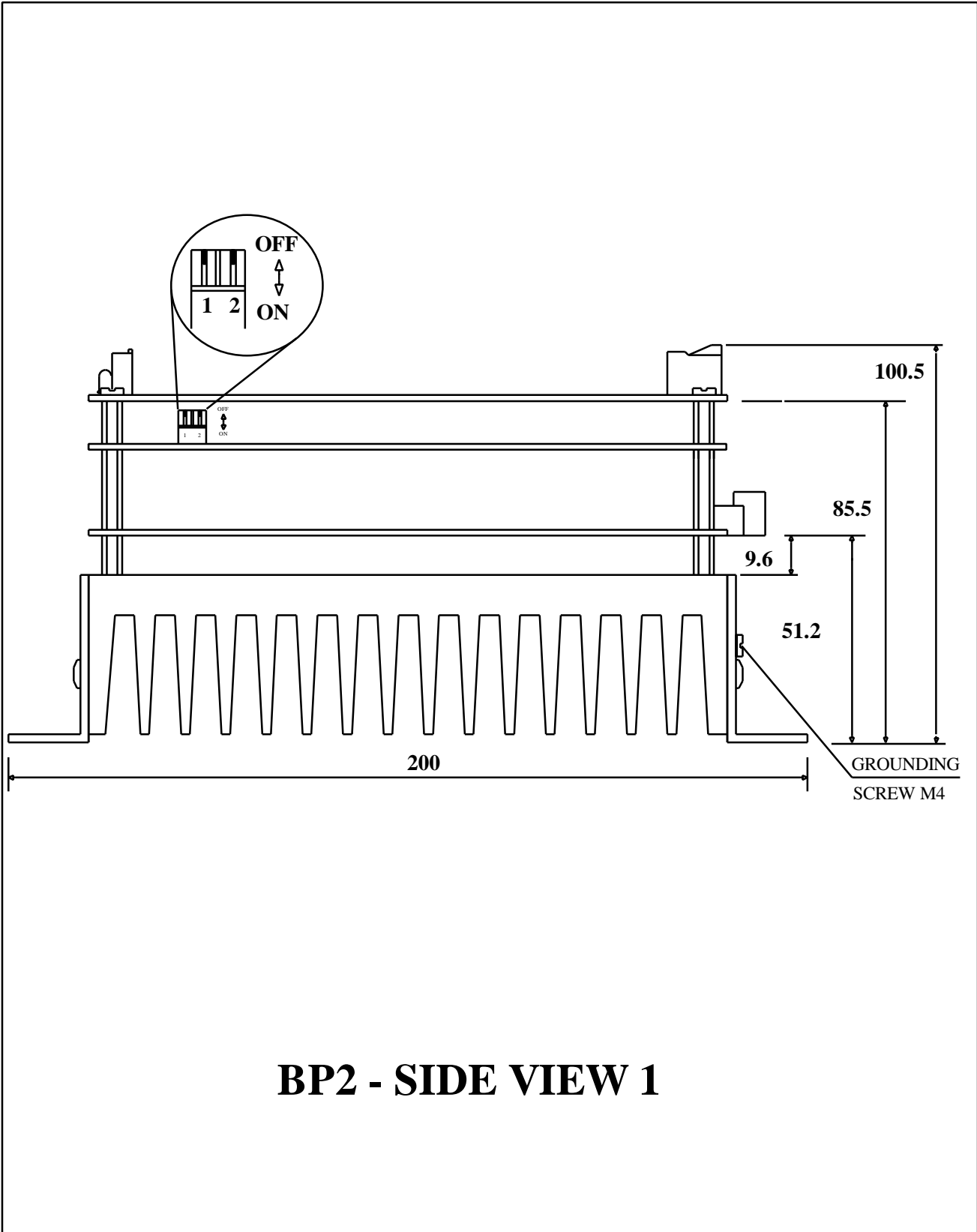

BP2 - SIDE VIEW 1

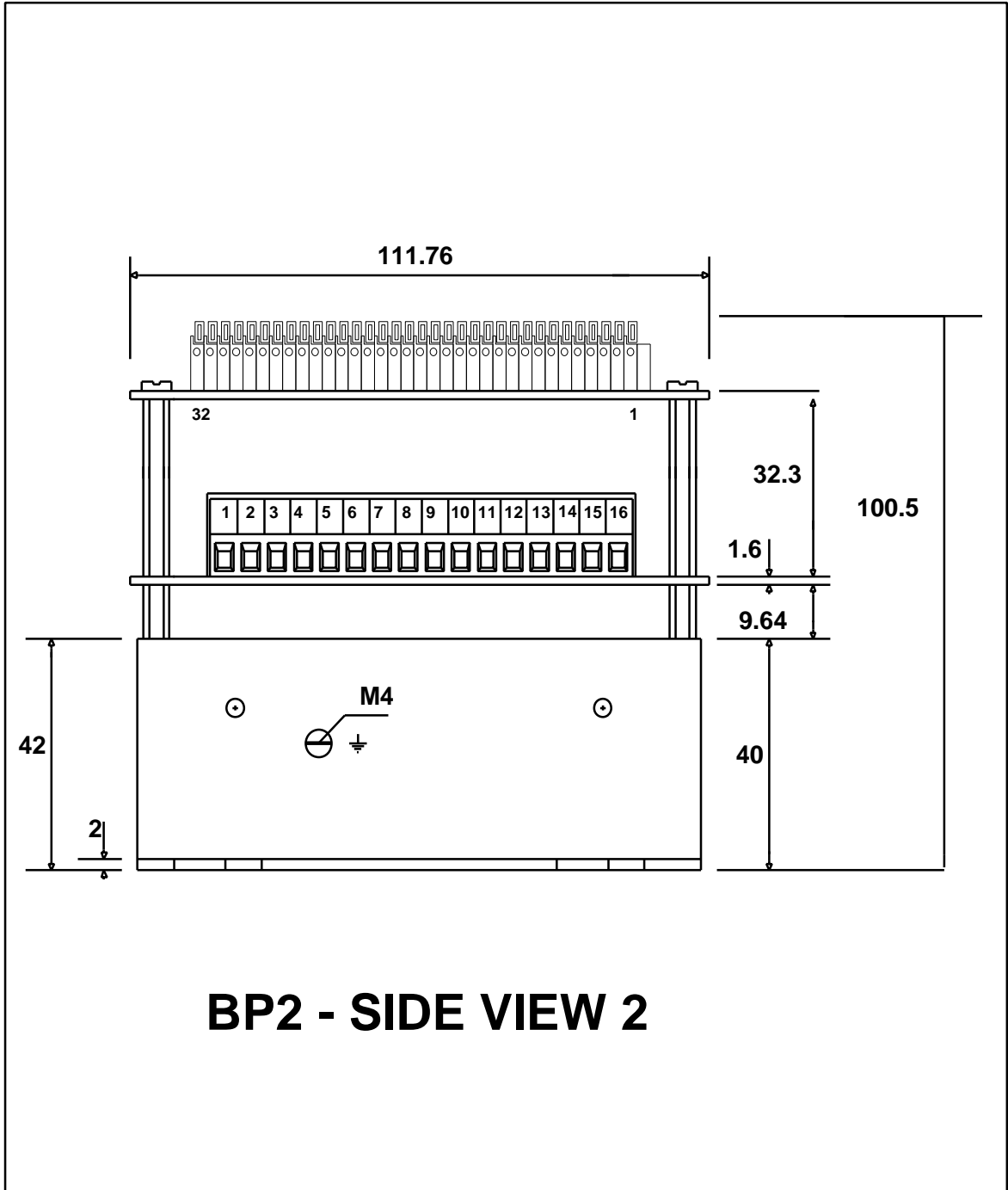

PANEL (H), BP3

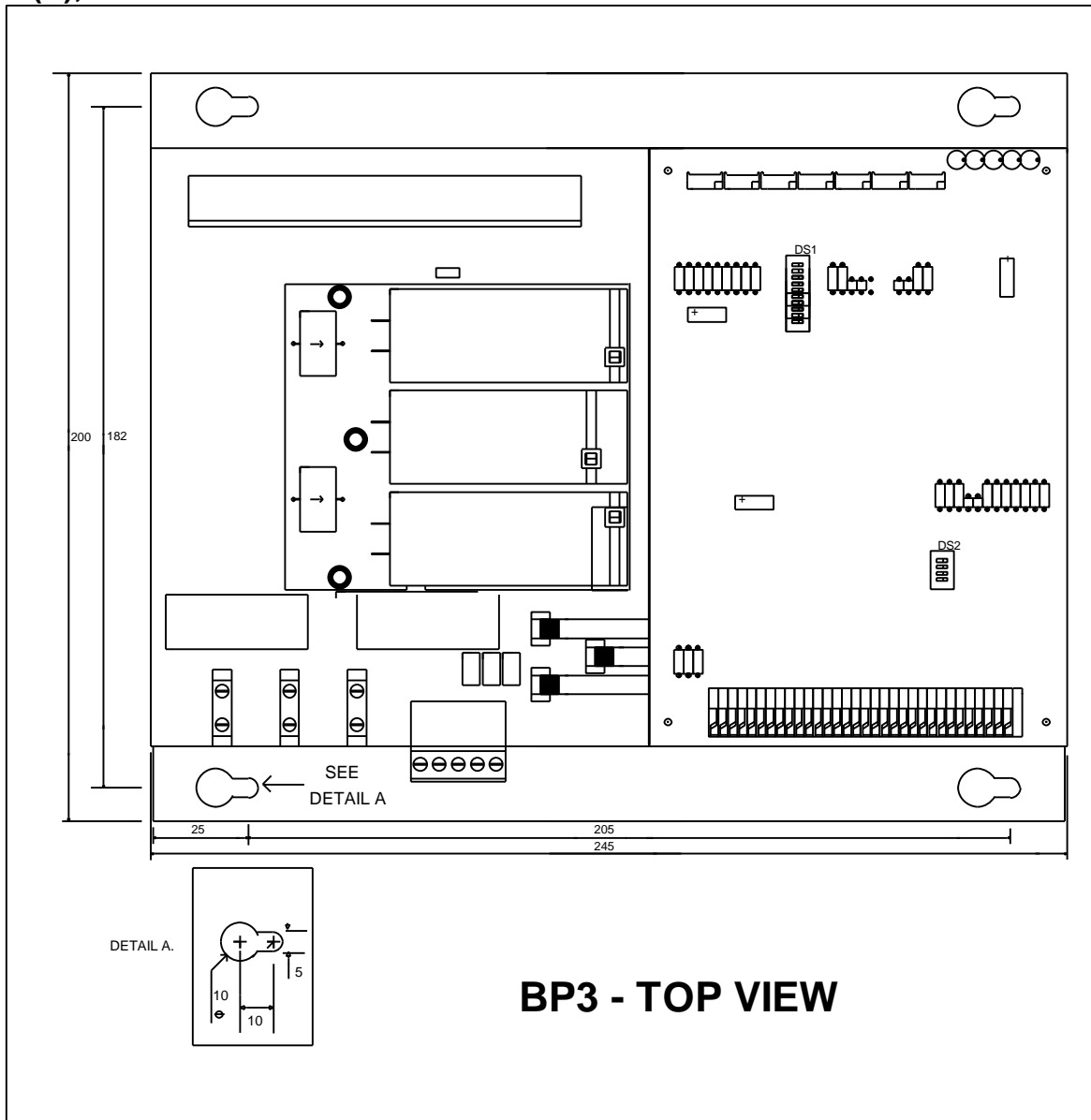

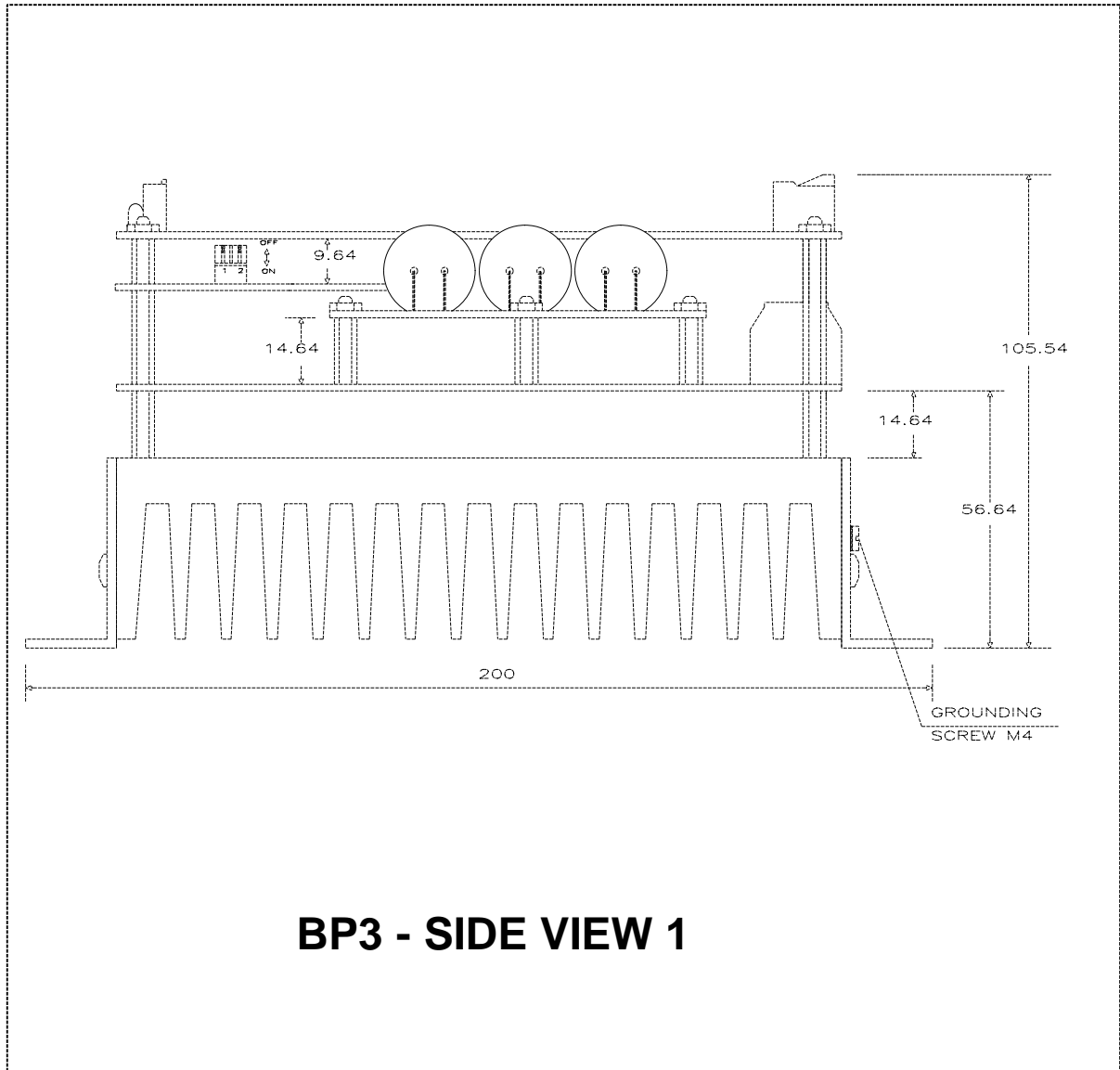

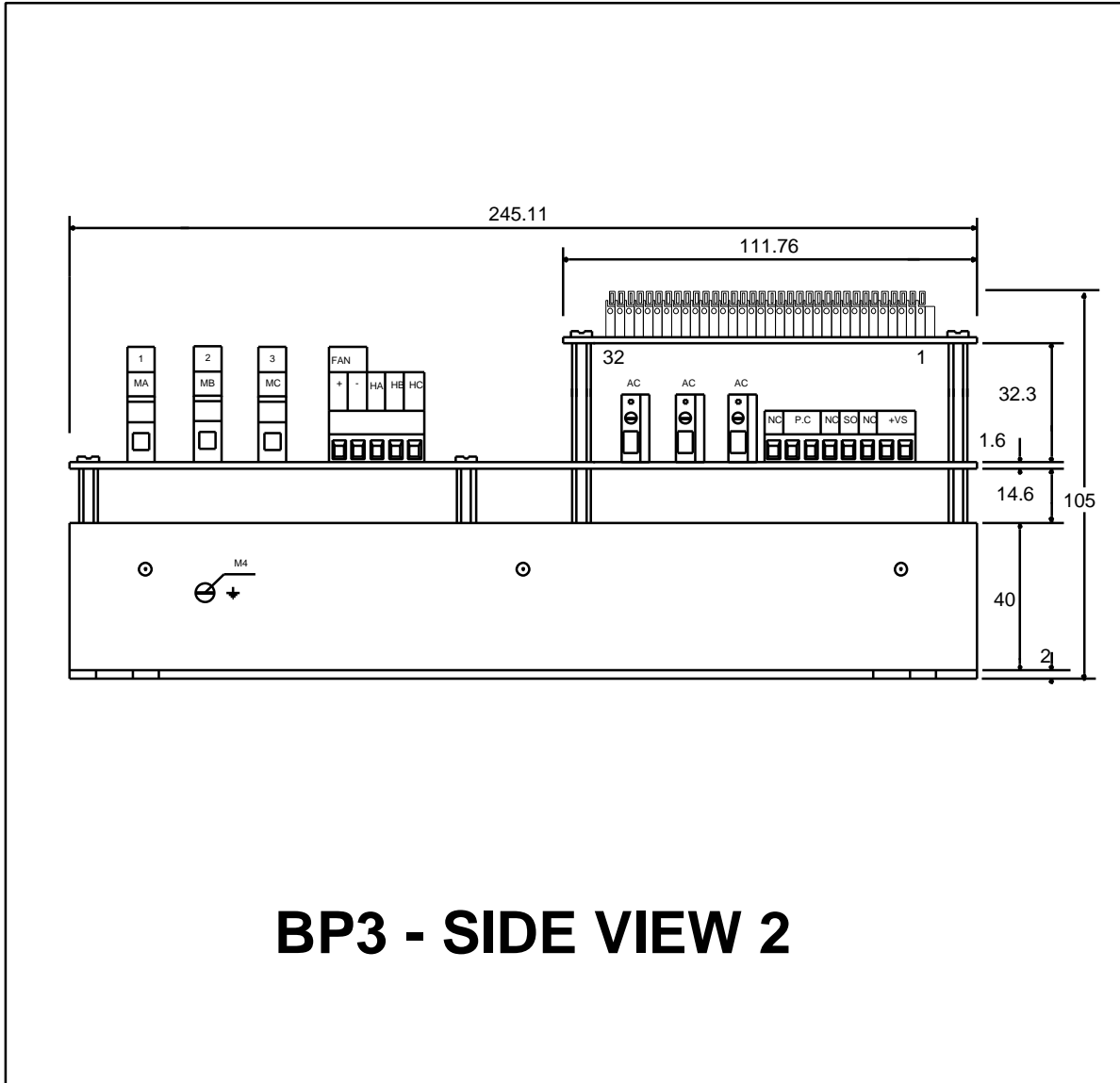

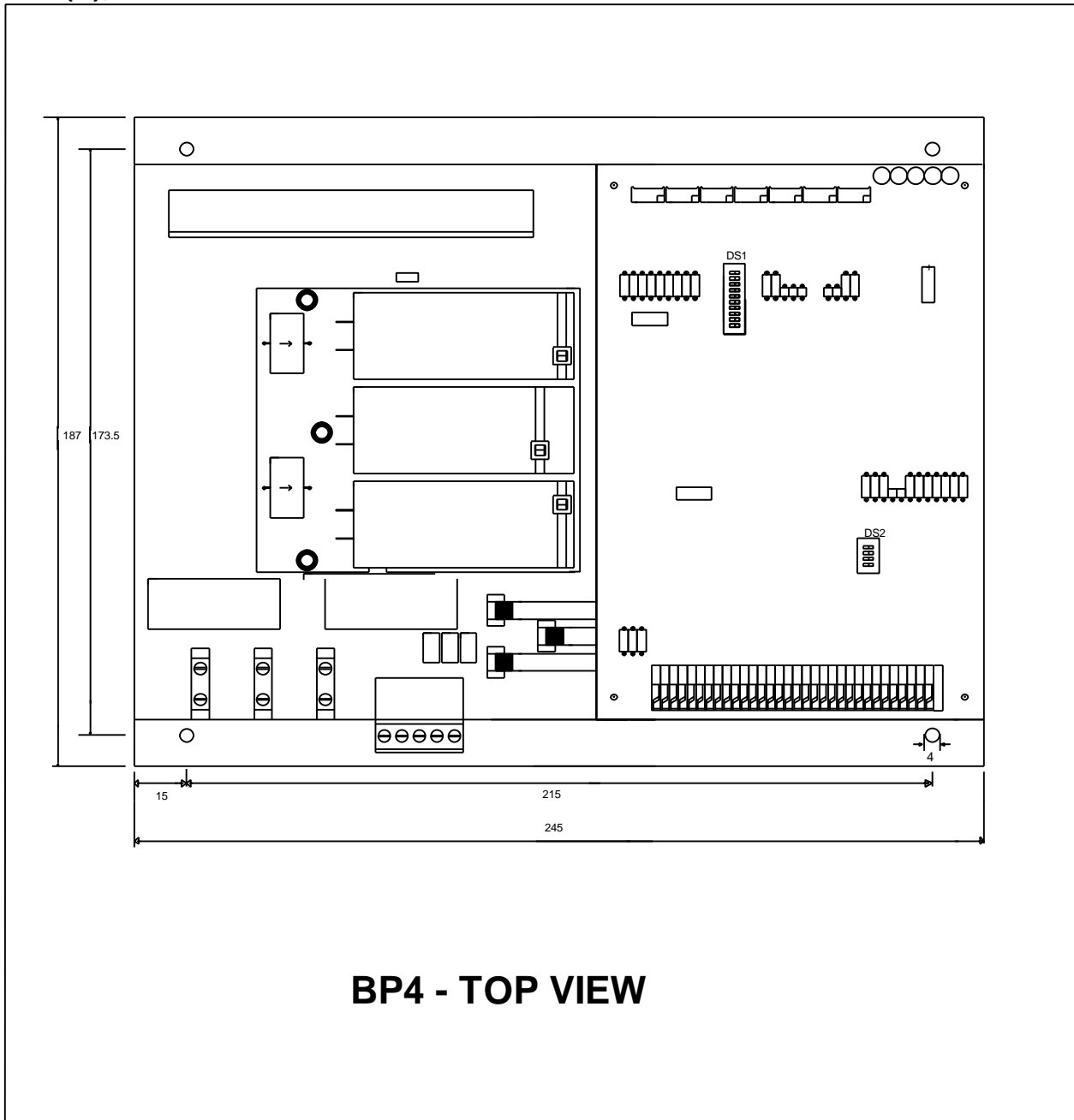
PANEL (H), BP4

SIDE VIEW

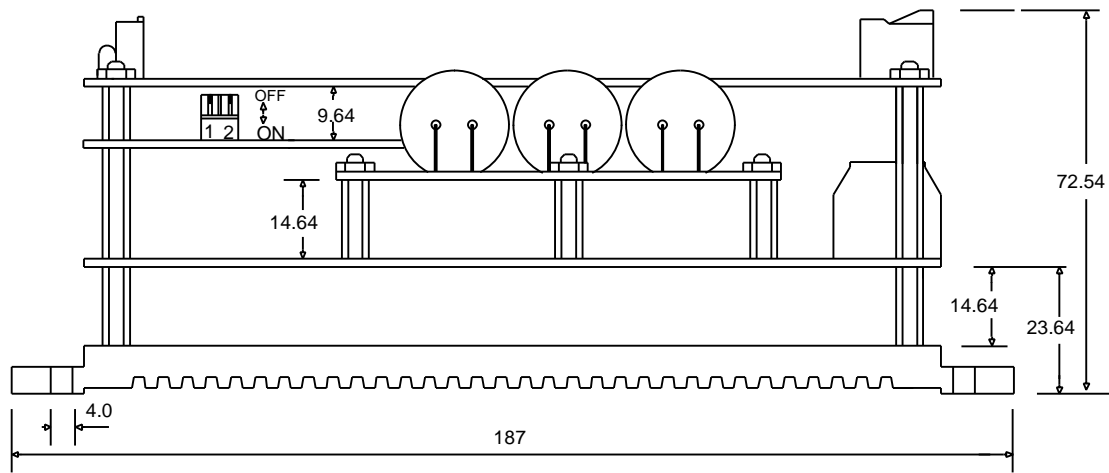
**BP4 - SIDE VIEW 1**

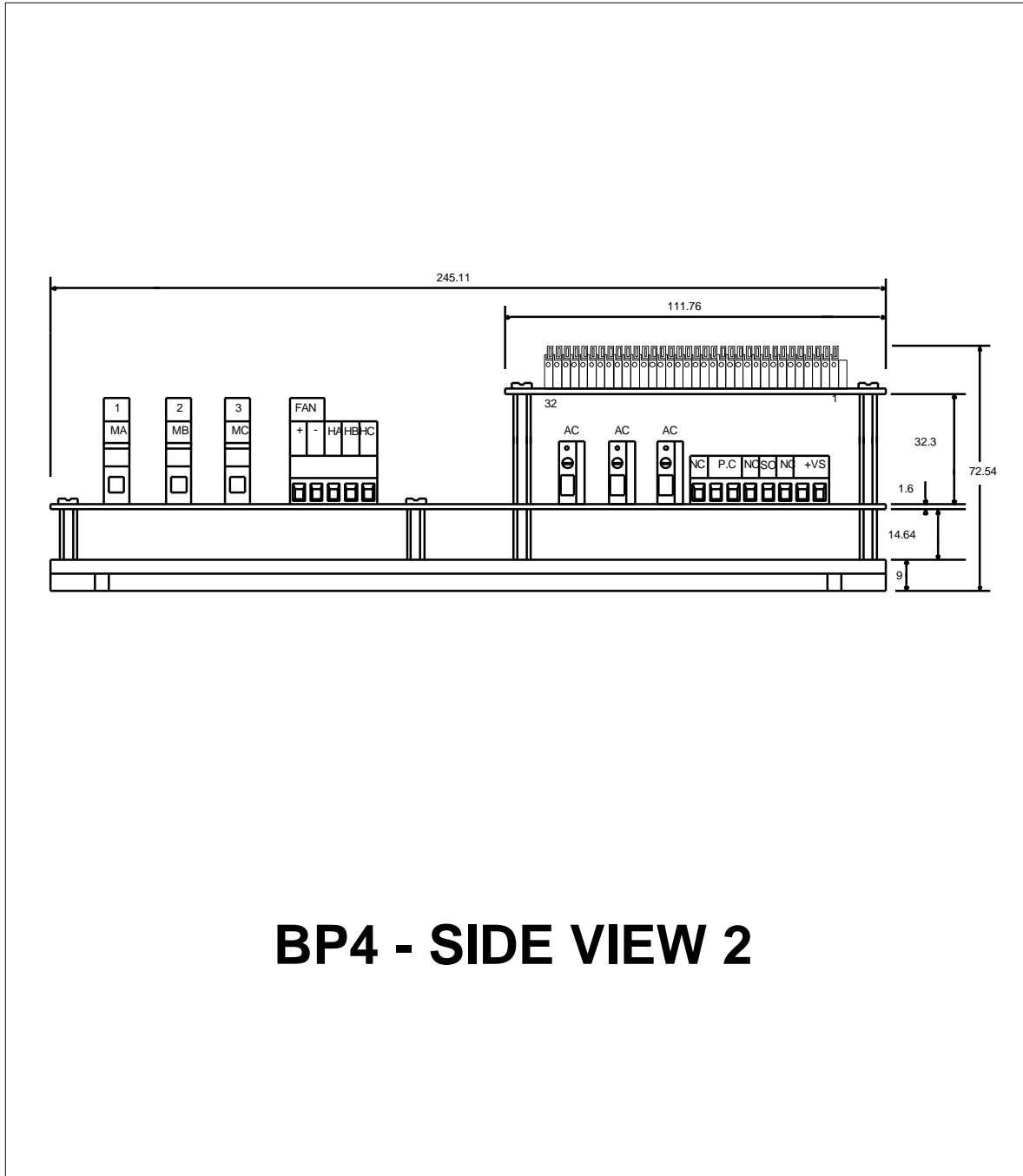

BP4 - SIDE VIEW 2

PANEL (H), BP6

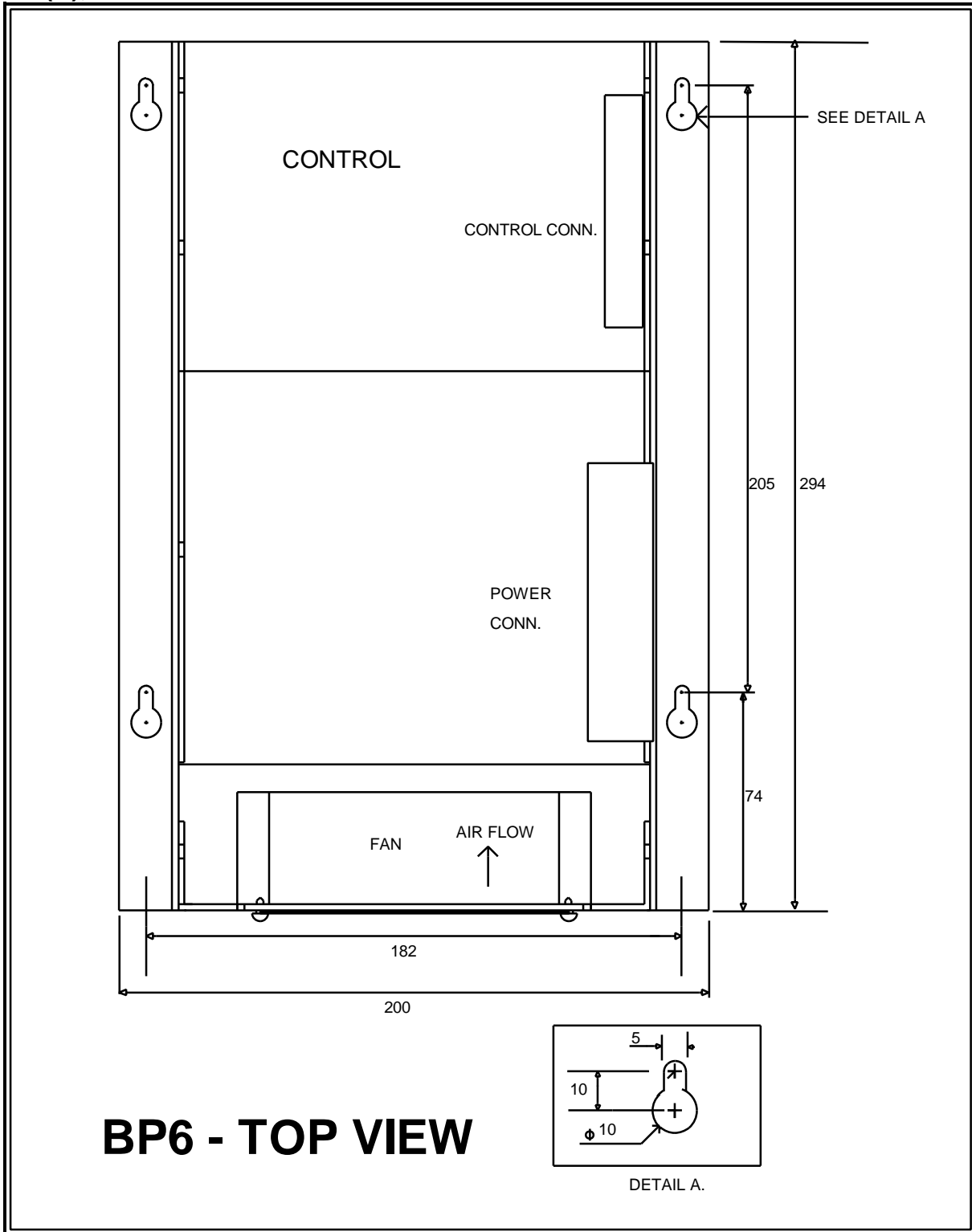

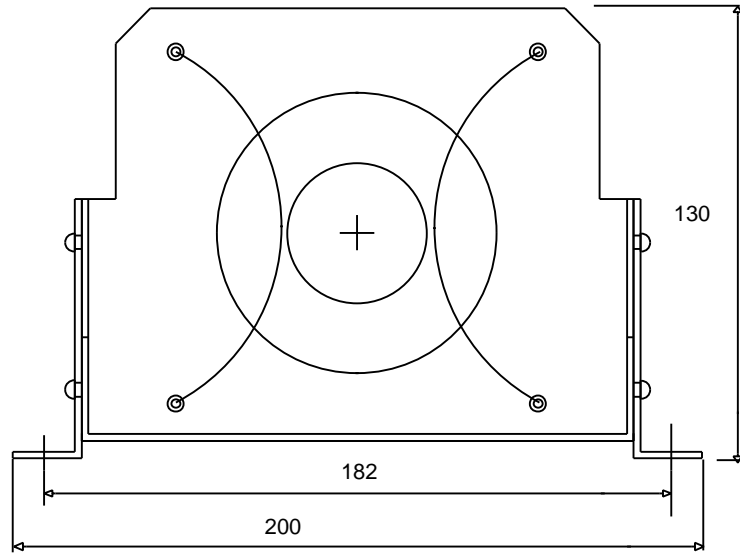

BP6 - SIDE VIEW 1

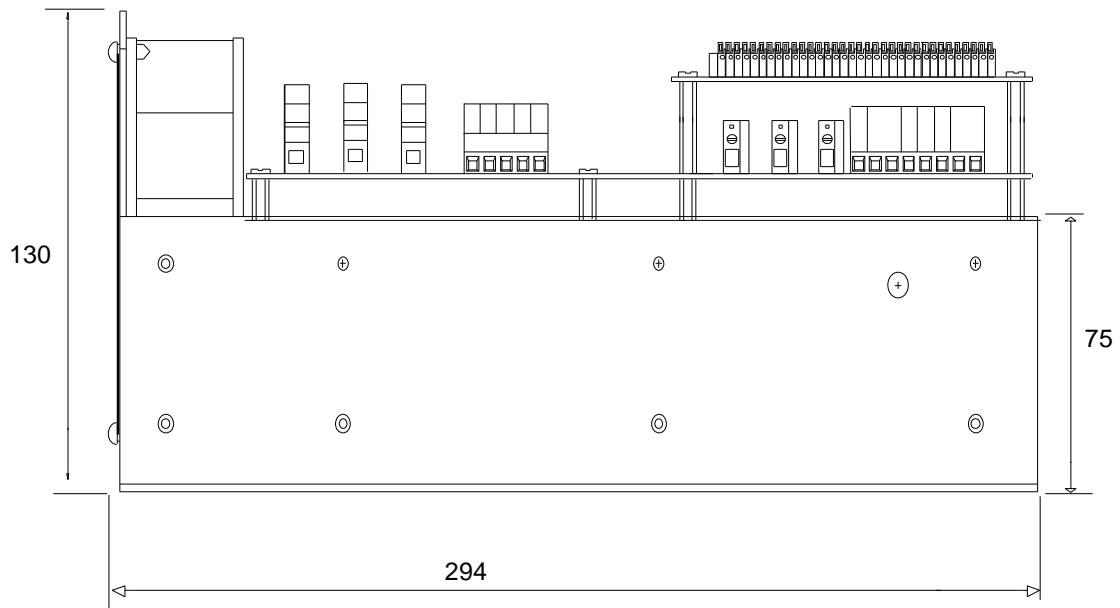

BP6 - SIDE VIEW 2

RACK 3U/12T

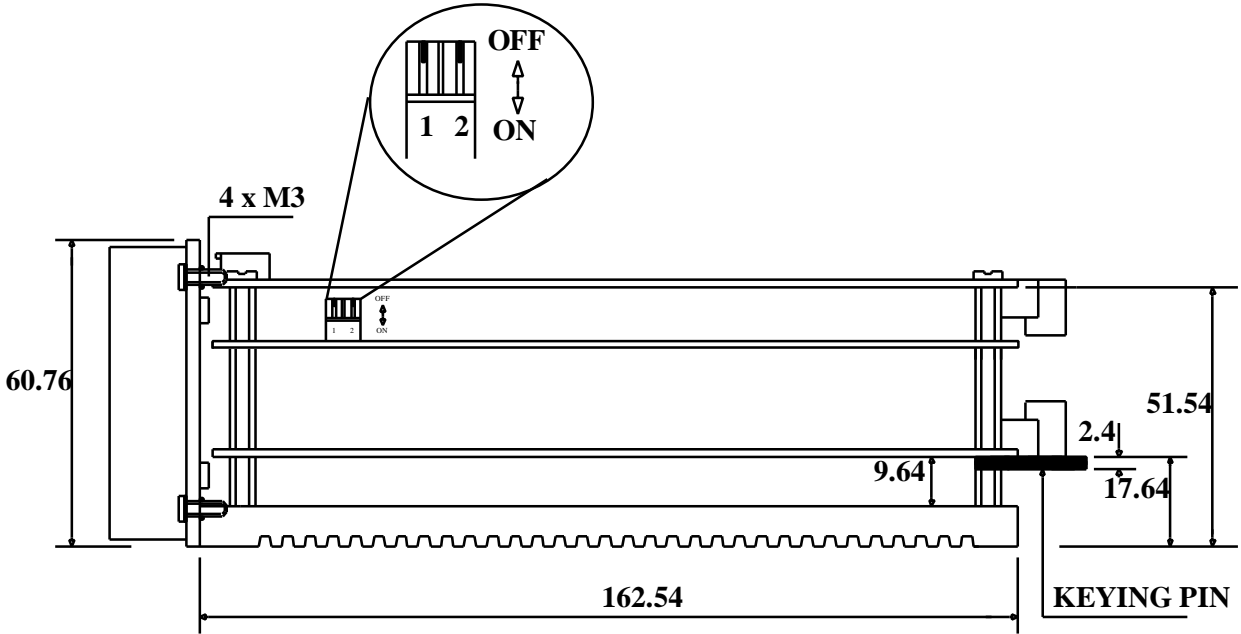

**IBP RACK MOUNTING (3U/12T)
SIDE VIEW 1**

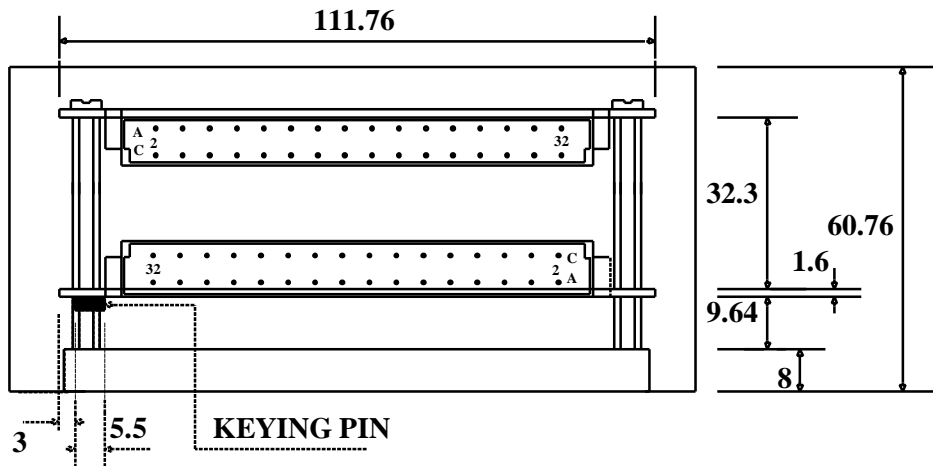

IBP RACK MOUNTING (3U/12T) - SIDE VIEW 2

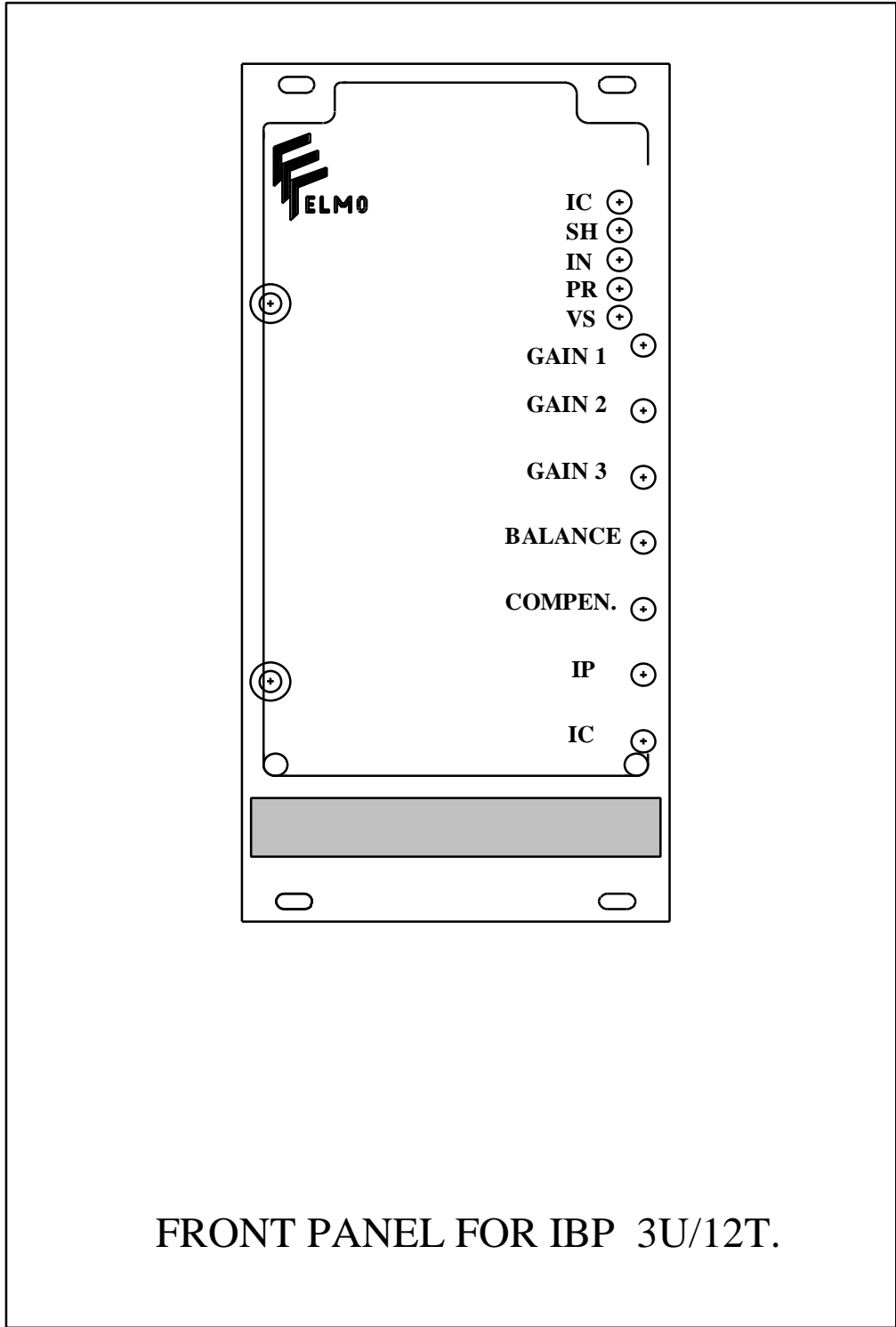

FRONT PANEL FOR IBP 3U/12T.

RACK 3U/19T

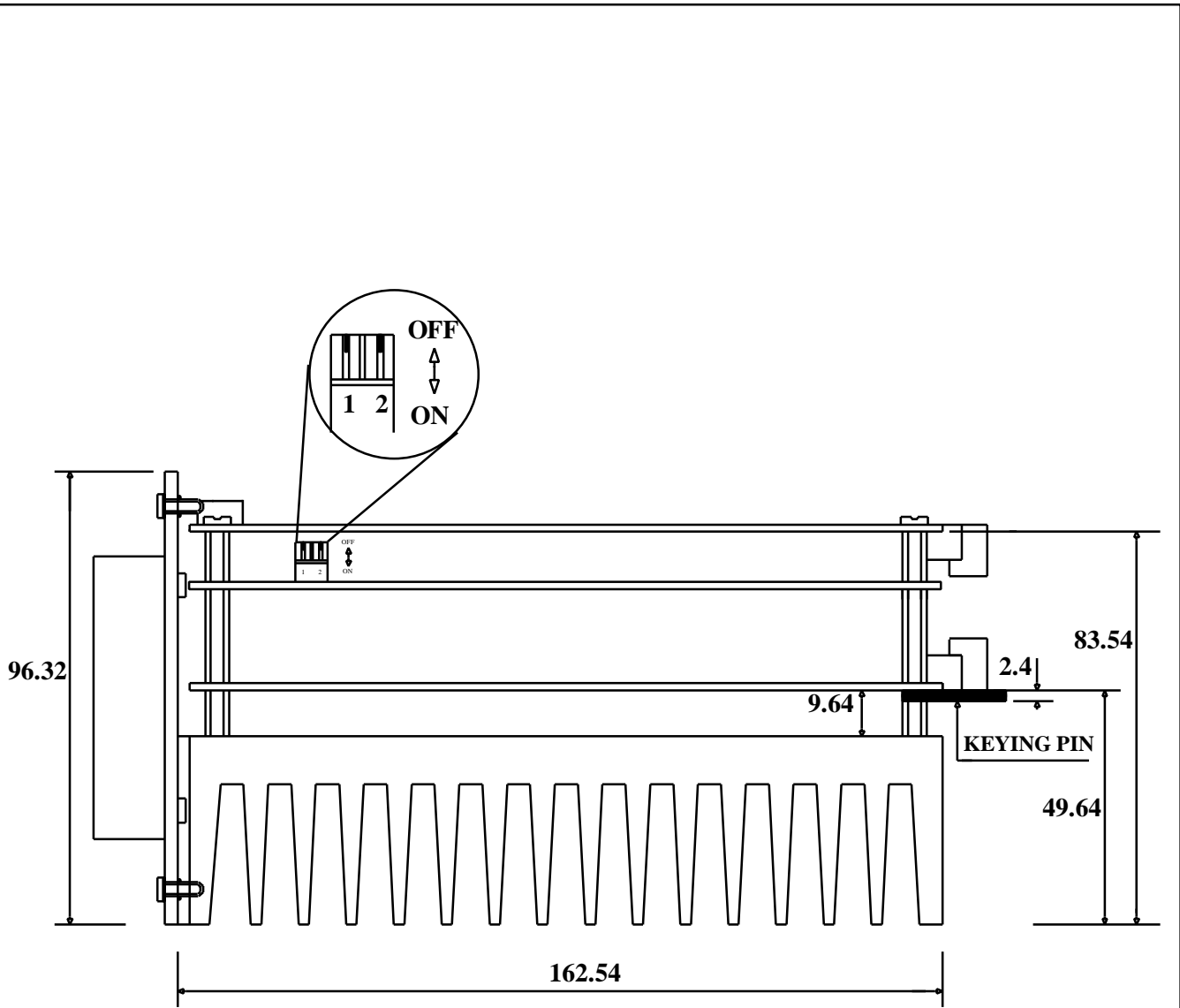

IBP RACK MOUNTING (3U/19T) - SIDE VIEW 1

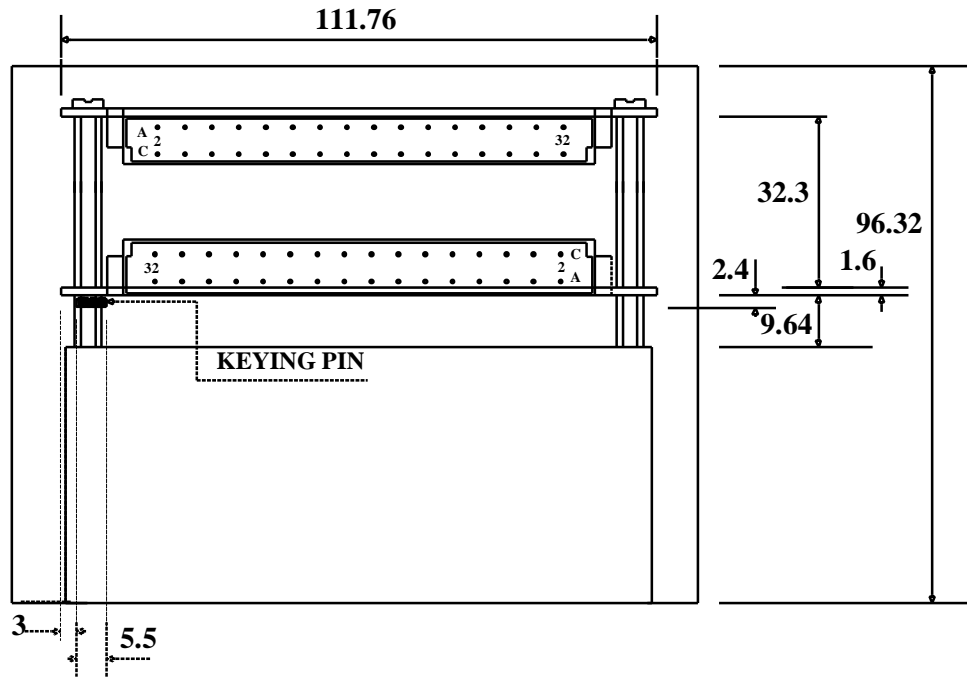

IBP RACK MOUNTING (3U/19T) - SIDE VIEW 2

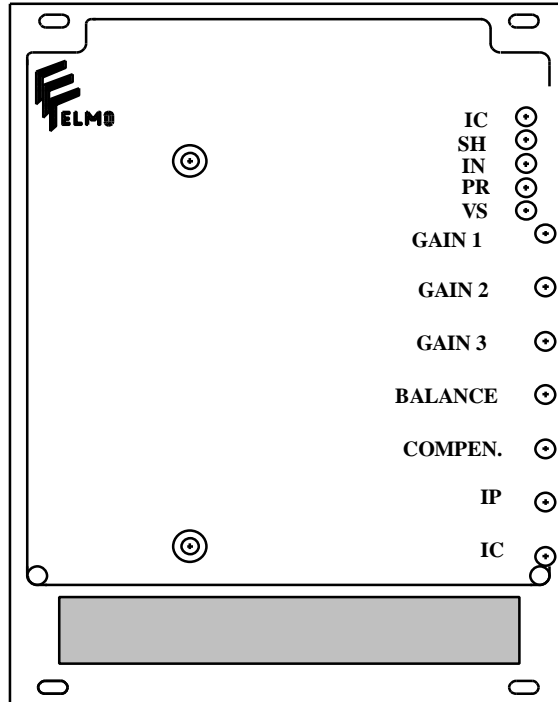

FRONT PANEL FOR IBP 3U/19T

RACK 6U/13T

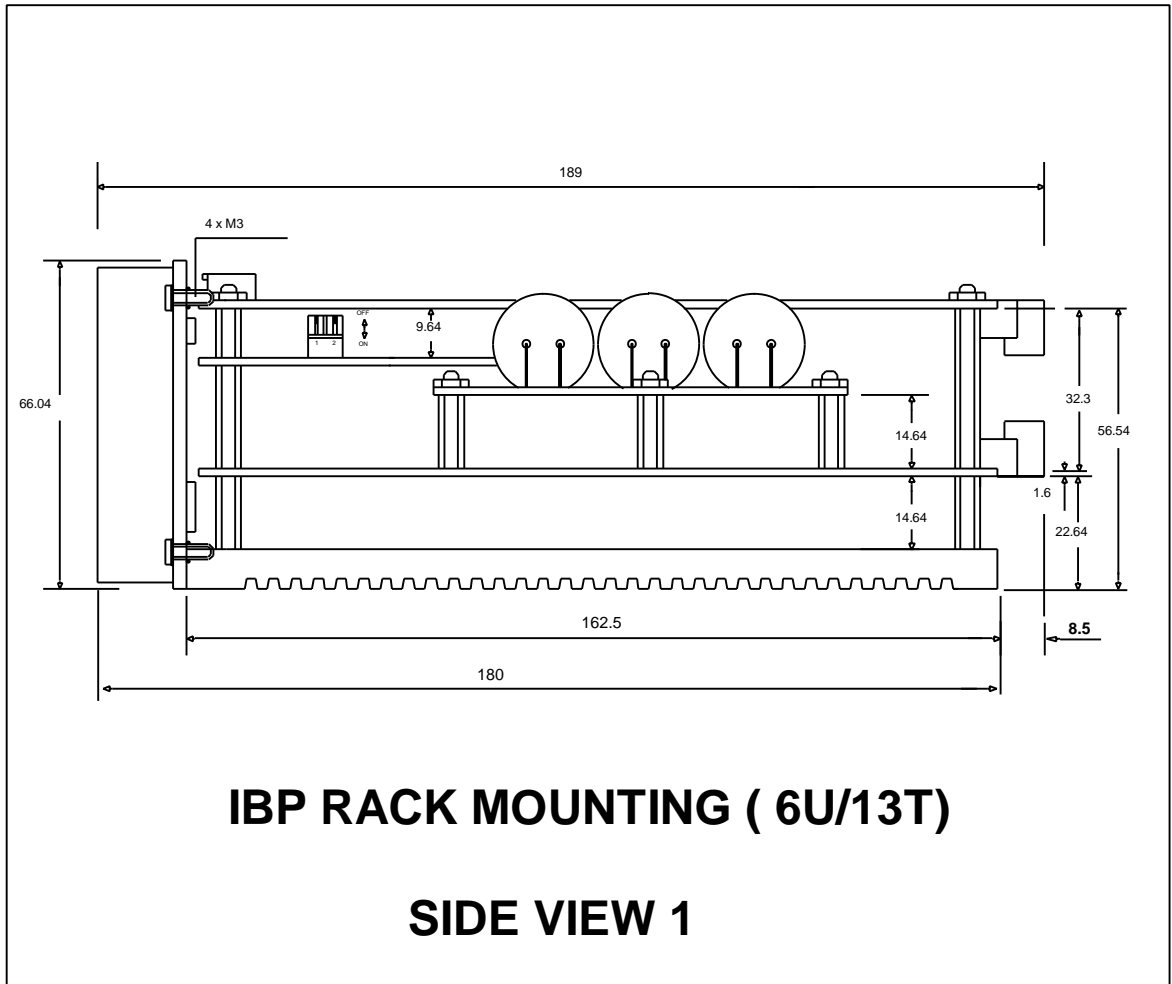

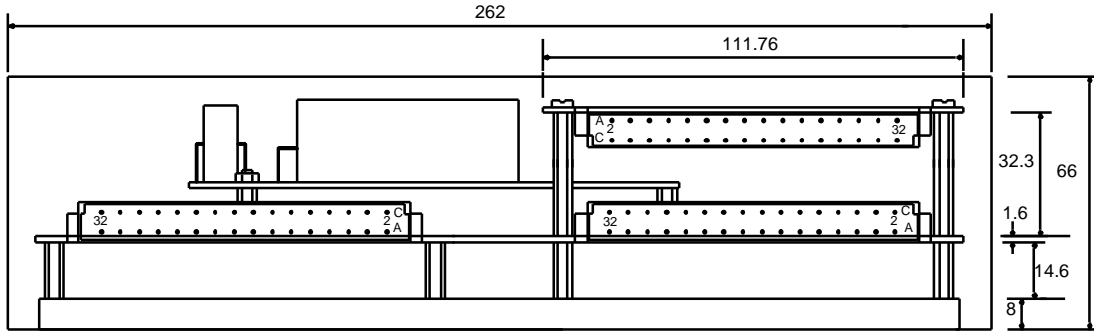

IBP RACK MOUNTING (6U/13T)

SIDE VIEW 2

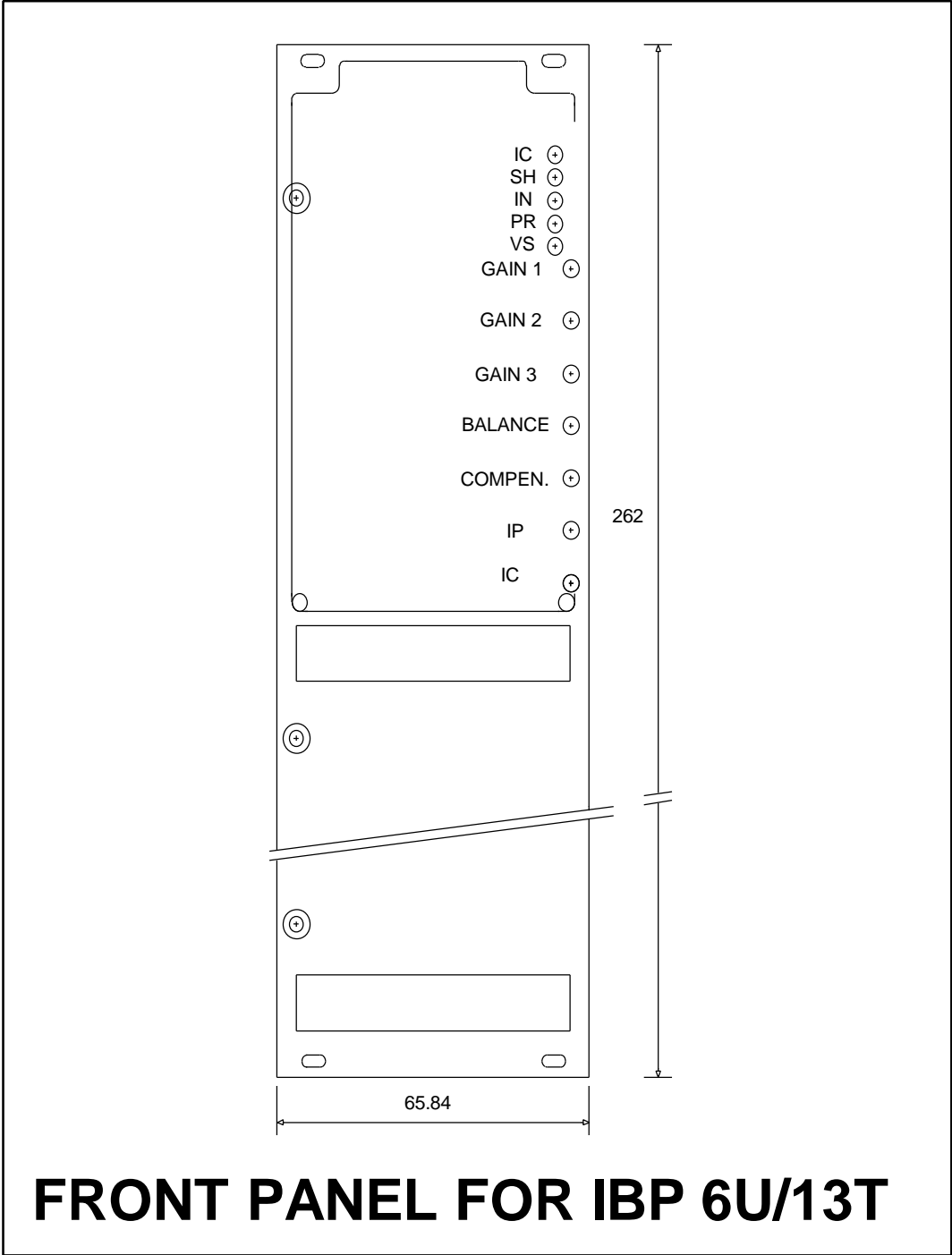

RACK 6U/20T

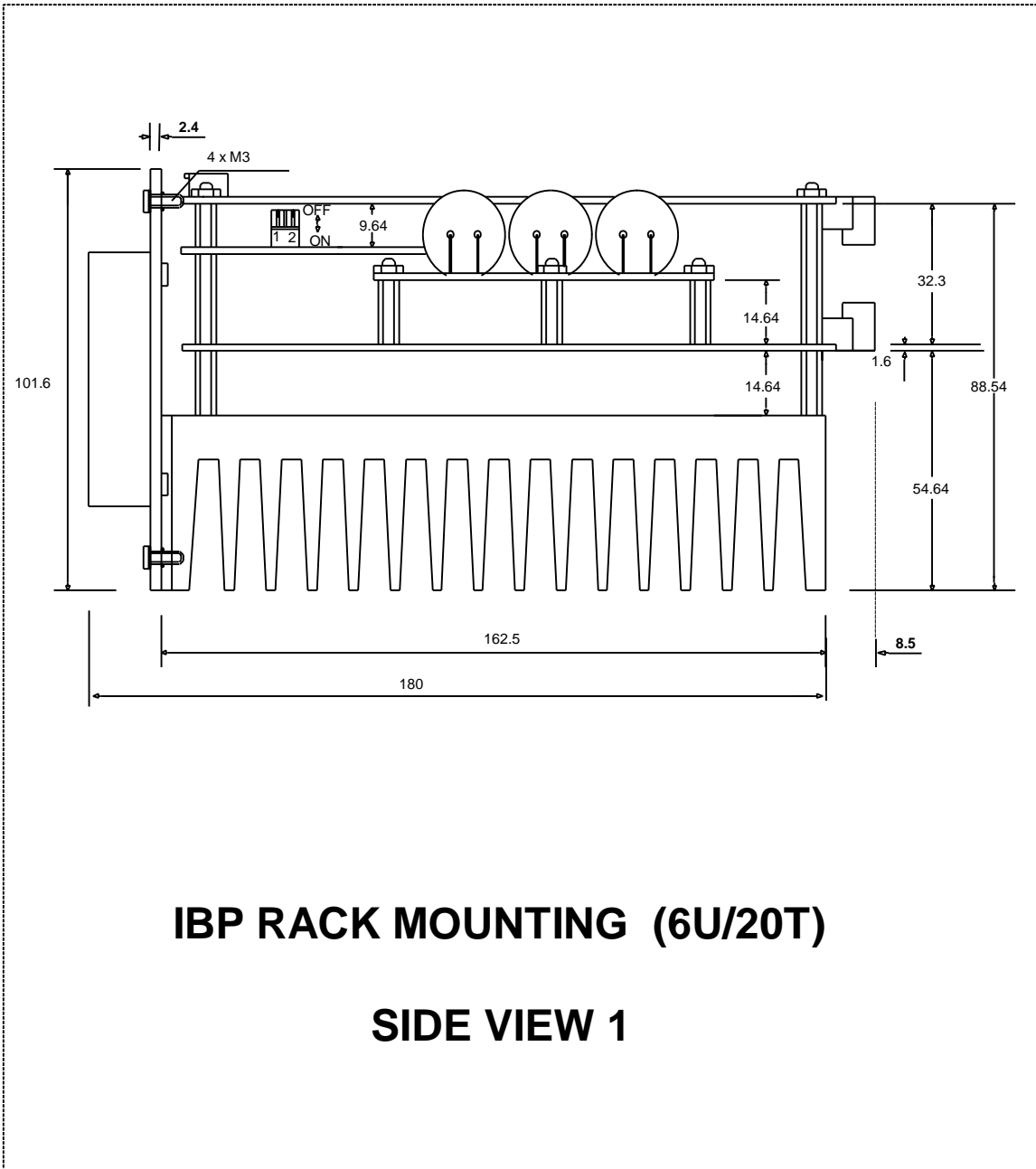

IBP RACK MOUNTING (6U/20T)

SIDE VIEW 1

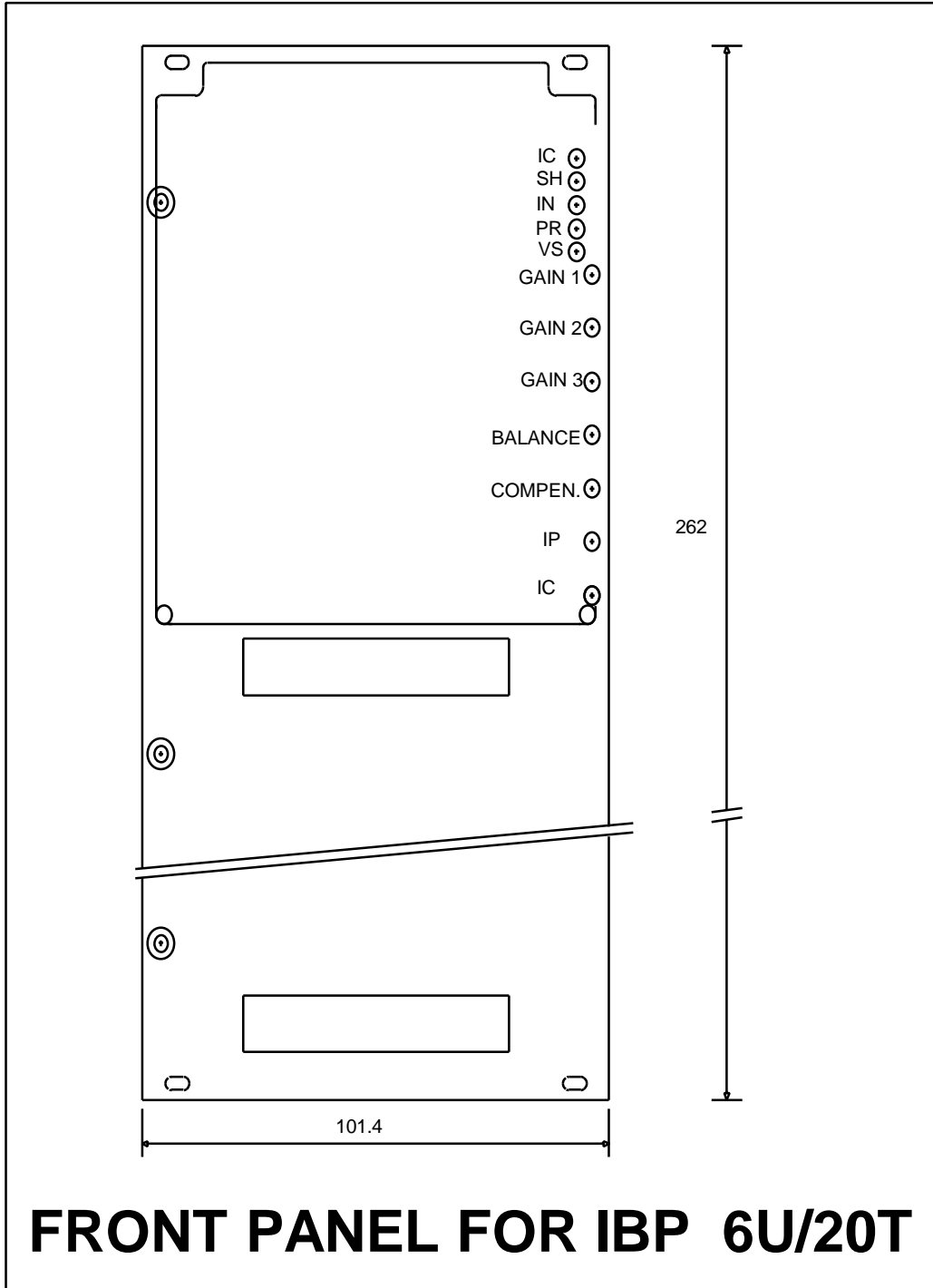

ENC- 3U/...

ENCLOSURE 3U

FRONT VIEW

SIDE VIEW

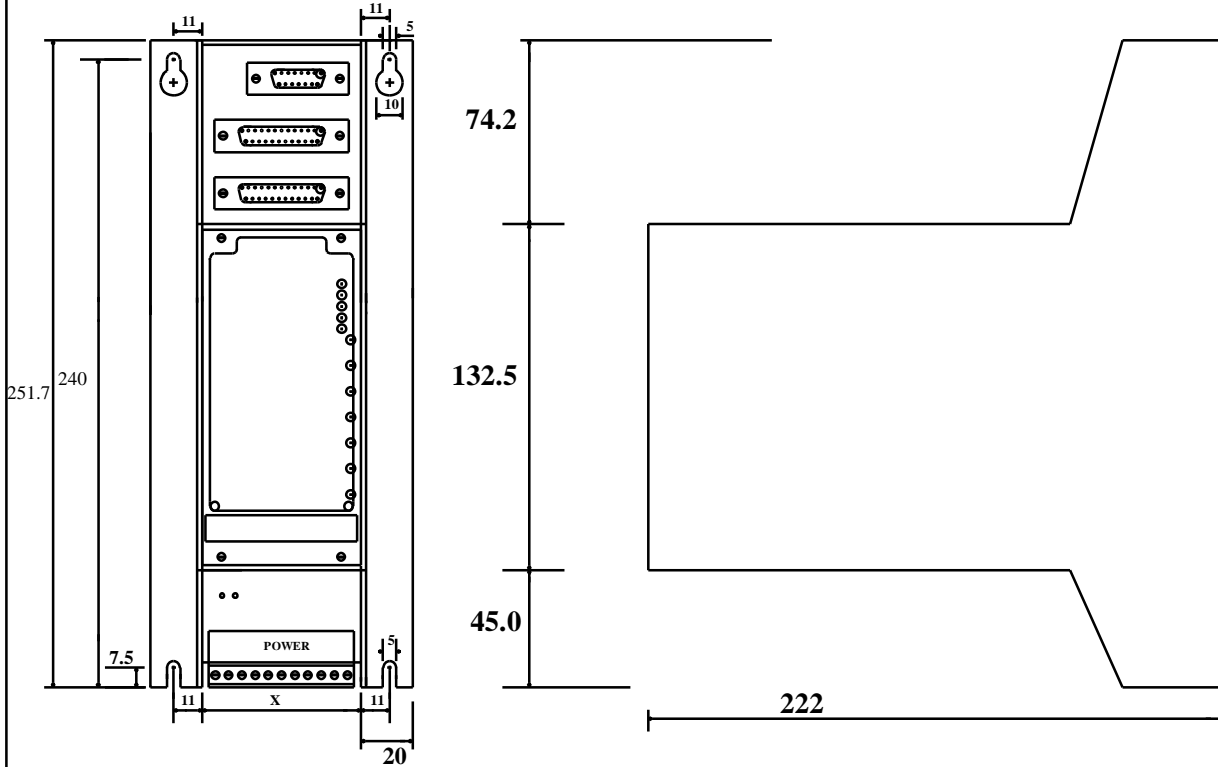

NOTE:

ALL DIMENSIONS ARE IN mm.

Standard Sizes

| | 12T | 16T | 20T | 24T | 36T |
|---|------|------|-------|-------|-------|
| X | 62.0 | 82.3 | 102.7 | 123.0 | 184.0 |

For non-standard sizes:

$$X = 5.08 \times n + 1\text{mm}$$

ENC - 6U/...

ENCLOSURE 6U

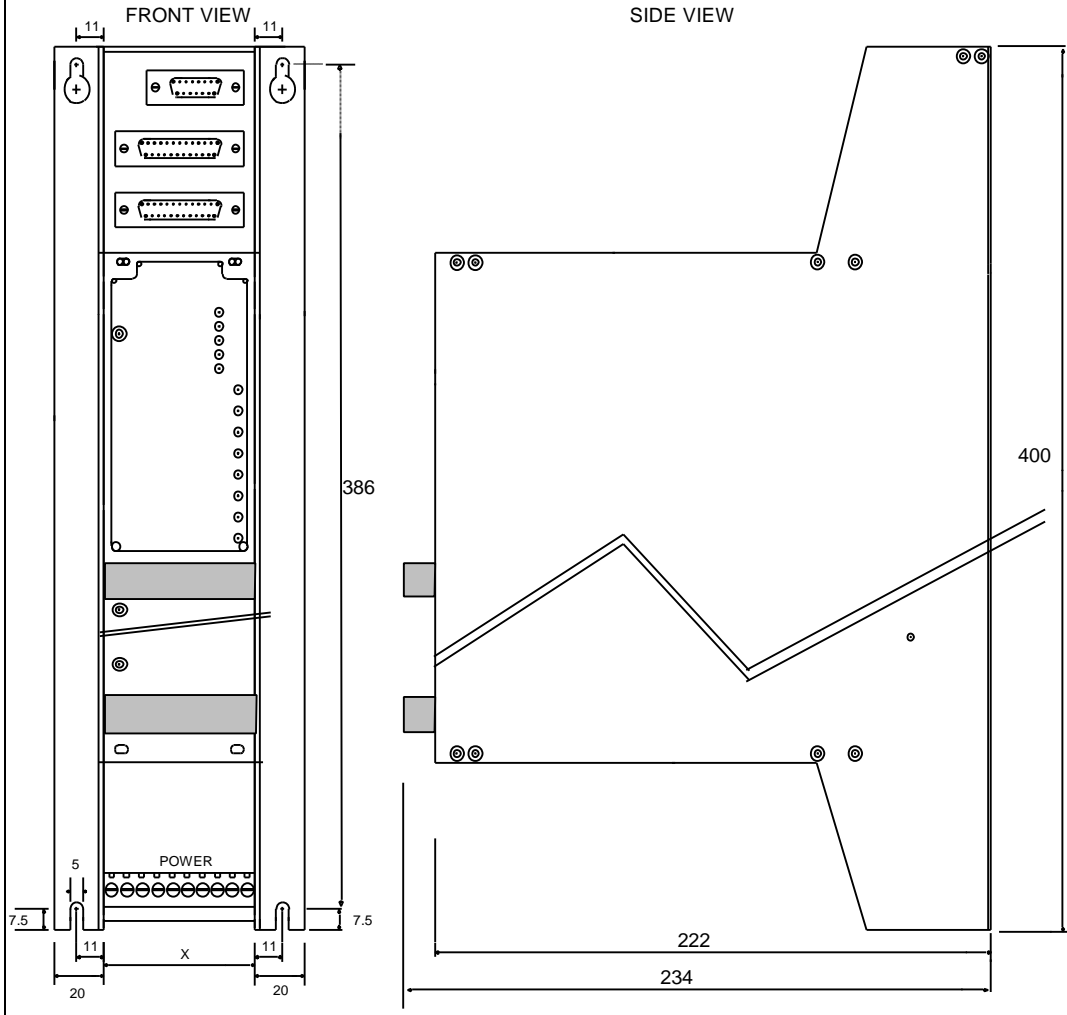

- NOTES:
1. ALL DIMENSIONS ARE IN mm.
 2. $X = n \times 5.08 + 1$, n = number of T

EXTERNAL SHUNT RESISTOR

EXTERNAL SHUNT RESISTOR (ESR)

TOP VIEW

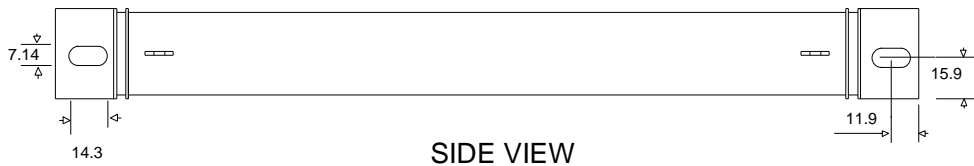

SIDE VIEW

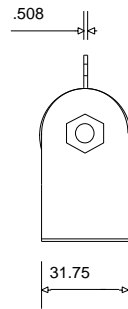

FRONT VIEW

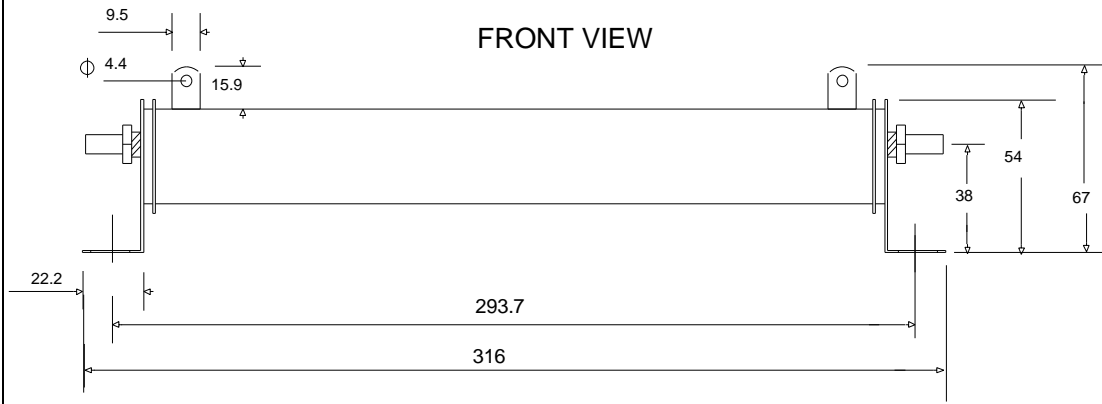

List of ELMO Service Centers**ISRAEL**

Elmo Motion Control LTD
 34 Segula ST.
 Petah-Tikva 49103
 Tel: (03)934-5059
 Fax: (03)934-5126

EUROPE

Elmo Motion Control
 7 Stanserstrasse
 CH-6362 Stansstad
 Switzerland
 Tel: (041)610775
 Fax: (041)610778

U.S.A

Elmo Motion Control INC.
 1200 Woodruff Road, Suite C-22,
 Greenville, SC 29607
 Tel: (803) 288-9316
 Fax: (803) 288-9318

AUSTRIA

Kwapil
 POB 64
 A-1091 Wien
 Tel: (0222) 342597
 Fax: (0222) 311203

BENELUX

Eltromat B.V.
 Looierij 26
 4760 AB Zevenbergen
 The Netherlands
 Tel: (01680) 25925
 Telefax: (01680) 28485

FINLAND

OY Scandrive
Elsankuja 2 K
SF-02231 Espoo
Tel: 358-0-8035044
Fax: 358-0-8035055

FRANCE

A 2 V SA
11-12 Rue Eugene Henaff,
78190 Trappes,
Tel: (1) 30620101
Fax: (1) 30626204

GERMANY

IME GmbH
Brugger str. 8
D-78628 Rottweil
Tel: 0741/22091
Fax: 0741/22060

ITALY

Servotecnica SRL
Viale Lombardia 20
20095 Cusano Milanino (MI)
Tel: (02) 66401010
Fax: (02) 66401020

SWEDEN

Aratron AB
P.O.B 20087,
Kratsbodavagen 50,
S-16120 Bromma
Tel: 8-981875
Fax: 8-984281

UNITED KINGDOM

INMOCO Limited
4 Brunel Close
Drayton Fields
Daventry NN11 5LE
Tel: 0327/300320
Fax: 0327/300319