

**The Gold Distributed Network  
Elmo's Motion Control System Solutions**

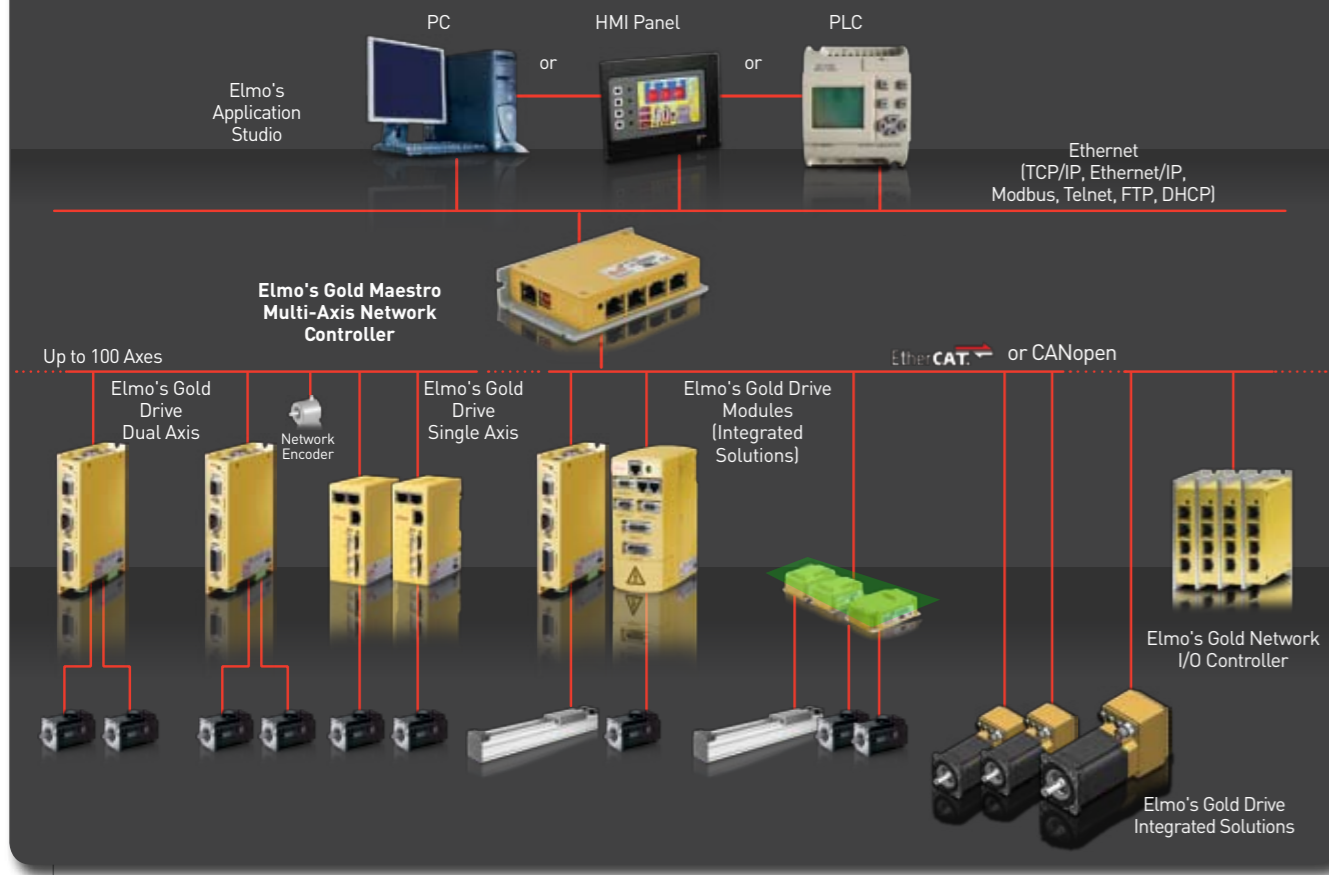

For more information on Elmo:

**Head Office**  
**Elmo Motion Control Ltd.**  
64 Gisin St., P.O. Box 463  
Petach Tikva 49103  
Israel  
Tel: +972 (3) 929-2300  
Fax: +972 (3) 929-2322  
info-il@elmomc.com

**North America**  
**Elmo Motion Control Inc.**  
42 Technology Way, Nashua  
NH 03060  
USA  
Tel: +1 (603) 821-9979  
Fax: +1 (603) 821-9943  
info-us@elmomc.com

**Europe**  
**Elmo Motion Control GmbH**  
Steinkirchring 1  
D-78056,  
Villingen-Schwenningen  
Germany  
Tel: +49 (0) 7720-85 77 60  
Fax: +49 (0) 7720-85 77 70  
info-de@elmomc.com

**Asia**  
**Elmo Motion Control Asia APAC**  
#807, Kofomo Building, 16-3  
Sunae-dong, Bundang-gu,  
Sungnam-si, Kyunggido,  
South Korea  
Tel: +82-31-698-2010  
Fax: +82-31-698-2013  
info-asia@elmomc.com

**The Gold Trombone Part Number**

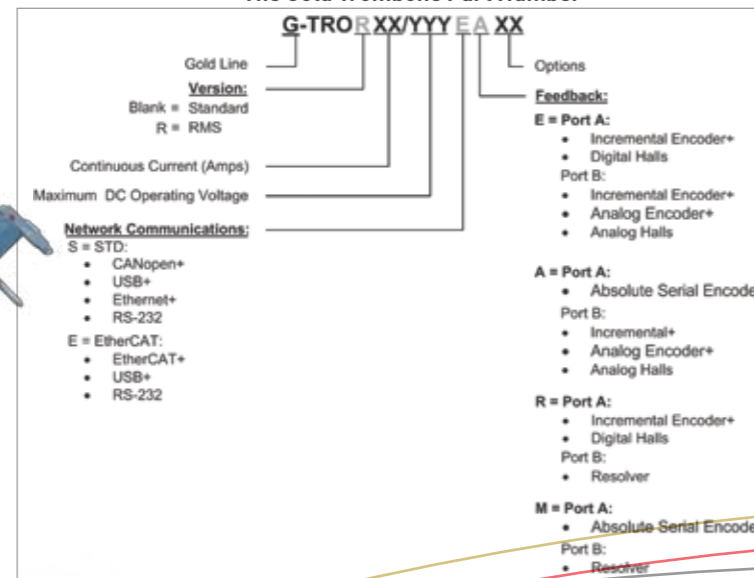

**The Gold Trombone**  
An Ultra-Compact 400 VDC & 800 VDC  
"Direct to Mains" Networking Servo Drive  
Up to 7 kW of Qualitative Power



# The Gold Trombone

An Ultra-Compact 400 VDC & 800 VDC  
"Direct to Mains" Networking Servo Drive  
Up to 7 kW of Qualitative Power

## Offering You Top Servo Solutions

The Gold Trombone – one of Elmo's newest Gold Line intelligent servo drives – is designed to operate "Direct to Mains" from a high voltage DC power supply of up to 400VDC or 800VDC, without the need for a transformer.

The Gold Trombone meets the highest level of motion control application requirements, providing top servo performance, advanced networking, built-in safety and high power density, combined with a fully featured motion controller and local intelligence.

## It's Easy to Implement Challenging Applications

In conjunction with Elmo's Gold Maestro, the ultimate distributed network motion controller, and the other members of Elmo's Gold Line of intelligent servo drives, state-of-the-art solutions for the most challenging multi-axis motion applications can be easily implemented, with a short development cycle while maintaining high performance.

## The Gold Trombone

- "Direct To Mains", no transformer is required.
- DC power of up to 400 VDC & 800 VDC.
- Ideal for any high performance application that requires rapid yet highly accurate movement of an electrical motor.
- Very high power density and on-board intelligence.
- One of the most compact "direct to mains" servo drives on the market

## Intelligence at the Axis Level

The Gold Line of servo drives incorporates Elmo's highly efficient and compact power density design together with the rich feature set of Elmo's proprietary, core motion control technology. The Gold Line solutions enhance servo performance with very high speed intelligent vector control, extremely wide bandwidth, advanced filtering, proprietary power switching technology, cogging and BEMF compensations.



## Ideal, Cost Effective Solutions for your Machinery

The combination of the Gold Line servo drives' unique characteristics, programming flexibility, a wide variety of feedbacks for closed loop operation, and EtherCAT and CANopen distributed networking, makes it an ideal, cost effective solution. The Gold Trombone also meets stringent industrial environmental conditions. A smart built-in power supply allows the Gold Trombone to operate with or without "supply back-up" functionality.



## Gold Line Servo Drive Highlights

### Servo Control

- Advanced and extremely fast vector control algorithm (Current loop bandwidth: 4 kHz).
- Current/Torque sampling rate: up to 25 kHz (40 μs)
- Velocity sampling rate: up to 12.5 kHz (80 μs)
- Position sampling rate: up to 12.5 kHz (80 μs)
- Up to 3 kHz electrical commutation frequency.
- Current close loop bandwidth exceeds 4 kHz.
- Position/Velocity/Acceleration command range – full 32 bit.
- Position over velocity, with full Dual Loop Support.
- Current gain scheduling to compensate for the motor's non-linear characteristics.
- Advanced filtering: Low pass, Notch, General B-Quad.
- Current loop gain scheduling to compensate for bus voltage variations.
- Velocity gain scheduling for ultimate velocity loop performance.
- Gains & filter scheduling vs position for mechanical coupling optimization, speed and position tracking errors.
- High order filters gain scheduling vs speed and position.
- S-curve Profile Smoothing
- Cogging, BEMF and  $\omega \times L$  compensation.
- Dual Loop Operation supported by Auto Tuning.
- Fast, easy and efficient advanced Auto Tuning.
- Incremental Encoder frequency of up to  $60 \times 10^6$  counts/sec.
- Motion profiler numeric range:
  - Position up to  $\pm 2 \times 10^9$  counts
  - Velocity up to  $2 \times 10^9$  counts/sec
  - Acceleration up to  $2 \times 10^9$  counts/sec<sup>2</sup>
- Large selection of feedback sensors.

### Motion Control

- Motion control programming environment
- Motion modes: PTP, PT, PVT, ECAM, Follower.
- Full DS-402 motion mode support, in both the CANopen and Can over EtherCAT protocols, including Cyclic Position/Velocity modes. Fast (Hardware) event capturing inputs, supporting < 1 μs latch latency.
- Fast (hardware) Output Compare, with < 1 μs latency.
- Output compare repetition rate:
  - Fixed Gap: Unlimited.
  - Table based: 4 kHz.
- Motion Commands: Analog, PWM, SW, Pulse and Direction.
- Distributed Motion Control.
- EAS (Elmo Application Studio): An efficient and user friendly Auto Tuner

### Communications

- Fast and efficient EtherCAT and CANopen networking.
- EtherCAT Slave:
  - CoE (Can over EtherCAT)
  - EoE (Ethernet over EtherCAT)
  - FoE (File over EtherCAT) for firmware download
  - Supports Distributed Clock
  - EtherCAT cyclic modes supported down to a cycle time of 250 μs.
  - Dynamic Objects Mapping (future option)
- CANopen (DS-301, DS-305, DS-402)
- Ethernet TCP/IP
  - UDP
  - Telnet
- USB 2.0
- RS-232

### Safety

- IEC 61800-5-2, Safe Torque Off (STO)
- UL508c recognition
- UL60950 compliance
- CE EMC compliance

### Outputs

- Four high voltage outputs (PLC compatible):
  - Conforms to IEC 61131-2
  - Up to 32 VDC
  - High side logic (Source)
  - Opto-isolated
  - Up to 250 mA
  - 500 mA for the brake
  - Short circuit protection
  - Thermal protection.
  - Reverse polarity protection
- Two fast outputs (5V logic)
  - Port C EIA-422 differential output line transmitters
  - Response time < 1 μs
  - $\pm 15$  mA output current.
- The four outputs can be configured to "5V Logic" (available on request)

### Inputs

- 2 STO (Safe Off Torque) inputs PLC level
- 6 Digital – Conforms to PLC Standard.
  - The 6 inputs + 2 STOs can be configured to "5V Logic" (available on request)
- 2 (out of the 6) PLC level fast digital capture data < 5 μs
- 2 Analog inputs  $\pm 10V$
- 2 very fast event capture inputs "5V logic".
  - Via Port A or B
  - EIA-422 Differential input line receiver.
  - Response time < 1 μs

### Feedbacks

- Flexible configurable Port A and Port B feedback input ports. Each port can be programmed to serve as:
- Commutation feedback and/or
  - Velocity feedback and/or
  - Position feedback
- Port A supports any one of the following sensors:
- Incremental Encoder
  - Increment Encoder + Digital Halls
  - Absolute Serial Encoder.
  - Absolute Serial Encoder + Digital Halls (for dual loop).
- Port B supports any one of the following sensors:
- Incremental Encoder
  - Analog Encoder
  - Analog Halls
  - Resolver.
- Port C: Flexible configurable feedback output port
- Encoder Emulation outputs of Port A or Port B or internal variables.
  - Analog Inputs ( $\pm 10V$  ptp). Can also be used for:
    - Velocity Feedback (Tachometer)
    - Position Feedback (Potentiometer).



### Feedback Sensors

- Incremental Quadrature Encoder (with or without commutation halls) up to  $60 \times 10^6$  counts per second (15 MHz on A/B)
- Digital Halls.
  - Up to 3 kHz commutation frequency.
  - "5V logic"
  - Input voltage up to 15 VDC.
- Incremental Encoder + Digital Halls
- Analog Encoders
  - 1 V PTP Sine/Cosine.
  - Sin-Cos Frequency: up to 500 kHz.
  - Internal Interpolation: up to  $\times 8192$ .
  - Automatic correction of amplitude mismatch, phase mismatch, signal offset.
- Analog Halls (commutation & position)
  - One feedback electrical cycle = one motor's electrical cycle.
  - 1 V PTP Sine/Cosine.
  - Sin-Cos Frequency: up to 500 kHz.
  - Internal Interpolation: up to  $\times 8192$ .
  - Automatic correction of amplitude mismatch, phase mismatch, signal offset.

- Absolute Serial (communication) Encoders:
  - NRZ (Panasonic, Tamagawa, Mitutoyo, etc.)
  - EnDAT 2.2
  - BiSS/SSI
  - HiPerface
- Resolver up to 512 rps with 14-bit resolution.
- Tachometer (available on request)
- Potentiometer (On request, contact us)
- The Gold Trombone provides 5 V supply voltage (5 V, 400 mA max) for the encoders' supplies

### Protection

- Built-in Protection & Diagnostics:
- Software error handling
  - Abort
  - Extensive status reporting
  - Protection against:
    - Shorts between motor power outputs and power return
    - Over temperature
    - Over/under voltage
    - Loss of feedback
    - Motor current
    - Current limits
    - Following errors
    - $i^2 \times t$  motor current

### Electrical Specifications

Feature	Units	12/400	R17/400	8/800	R11/800
Minimum supply voltage	VDC	80		200	
Nominal supply voltage	VDC	330		640	
Maximum supply voltage	VDC	400		750	
Maximum cont. electrical output power from the drive	W	Up to 7 kW of continuous qualitative power			
Efficiency at rated conditions	%	> 98			
Auxiliary supply voltage (ext.) option	VDC	16.5 V – 32 V			
Auxiliary Power Supply	VA	≤ 5 VA without external loading ≤ 8 VA with full external loading			
Continuous current limit (Ic) Amplitude of sinusoidal or DC trapezoidal commutation	A	12	17	8	11
Continuous RMS sinusoidal commutation (Ic)	A	2 x Ic	NA	2 x Ic	NA
Weight	g (oz)	315 g (11.1 oz)			
Dimensions	mm (in)	110 x 75 x 30 mm (4.33" x 2.95" x 1.18")			
Mounting Method	A	PCB Mounted			
Digital In / Digital Out / Analog In	A	6 / 2 / 1			

### Dual Loop Options

		Port A				
		Incremental Encoder + Digital Halls	Incremental Encoder	Digital Halls	Absolute Serial Encoder	Absolute Serial Encoder + Digital Halls
Port B	Incremental Encoder	Yes	Yes	Yes	Yes	Yes
	Analog Encoder	Yes	Yes	Yes	Yes	Yes
	Analog Halls	Yes	Yes	Yes	Yes	Yes
	Resolver	Yes	Yes	Yes	Yes	N/A

