

Elmo's **Next Generation** **One Solution One Environment**

Small, Smart & Simple



Elmo's Next Generation

Elmo's **Next Generation** meets the ever-growing demand for an advanced and comprehensive solution for motion control applications that are becoming more complex. The **Next Generation** provides a state-of-the-art answer to the current and future needs of the motion control market.

Equipped with Elmo's powerful core servo and motion control technology, the **Next Generation** provides the highest power and intelligence density and the most efficient networking, while complying with the known standards. This extremely compact solution is an evolutionary achievement unparalleled by any other manufacturer in the industry.

The **Next Generation** delivers optimal results for a wide range of applications, for a variety of challenging industries where system control combined with precision and deterministic operation is paramount, including:

- Robotics
- Semiconductors production
- Avionics
- Machine tools
- Packaging
- Wood processing
- Textiles
- Medical and Pharmaceutical instruments
- Printing/Converting
- Sorting
- Material handling instrumentation
- Defense

The **Next Generation**, the breakthrough solution from Elmo, achieves new levels of motion control efficiency to ensure the most effective implementation of an application that embraces:

- **Global system** - a multiplicity of motion applications in one solution.
- **Top level servo & motion performance**
- **Simplicity** - an application-oriented implementation environment ensures quick and easy implementation for even the most complex applications.
- **Intelligence** - for optimum results, both at the machine motion control level and at each axis
- **"Go Standard"** - Elmo's implementation of the application environment and the communication protocols is fully compliant with the leading standards. The user retains maximum flexibility to add, upgrade, expand and replace any member of the network.
- **Flexibility** - Elmo's compact products can easily be mounted anywhere and offer a broad range of communication hardware configuration possibilities.
- **Robust and Deterministic** - reliable and resilient in the face of changing conditions.

Elmo's technology is a revolutionary force in the motion control market and brings an entirely new perspective to the standard expectations for controller performance and functionality.

Elmo Motion Control is the innovative provider of feature-rich motion control products for machine manufacturers. For more than twenty years, Elmo has been designing, producing and marketing network-based motion controllers, intelligent digital servo drives and highly efficient servo amplifiers for both brush and brushless motors.

Next Generation Architecture

Elmo's **Next Generation** raises the competitive standards in motion control with precise motion control, superior synchronization and deterministic timing and communication, while upholding simplicity, modularity and full compliance with industry standards.

System control and supervision coupled with local axis intelligence and fast response to local motion events are among the outstanding qualities that distinguish Elmo's **Next Generation** solution in the motion control arena.

The **Next Generation's** three-layered architecture distributes intelligence throughout the motion control system: From the programming, development and management PC layer, through the machine motion controller layer and the axis drive layer. Each level of architecture contains peerless, localized logic and management capabilities to fulfill the exacting requirements of your motion control application.

Three Layers for Integrated Motion Control from Top to Bottom, Within a Single Environment

- Elmo Application Studio (The EAS)
- The Network Motion Controller (The Master Drive machine motion controller is one of three configuration options)
- The Intelligent Drive

Elmo Hands One Solution in One Environment to Motion Control Engineers

Using Elmo's **Next Generation** makes it possible to design a project with multiple intelligent system nodes in a unified common programming environment. The **Next Generation's** three interlocking layers offer seamless integration with components from various manufacturers and a single point of contact for technical support.

Elmo Application Studio (The EAS) 1st Layer

The **Elmo Application Studio** is a friendly, easy-to-use application environment. The EAS supports two independent standard programming environments: Both IEC 61131-3 and C programming/ development platforms.

The EAS provides tools to set up the control, motion and communication, as well as tools for advanced tuning, monitoring, recording and logging.

The EAS liberates engineers from investing the majority of resources to deal with the communication and motion networks, and thus empowers them to focus on the application, while maximizing their motion resources and resolving the labor-intensive process of becoming the "expert" in communication and/ or motion control.

With the EAS development environment, an engineer can develop a complete application within a single project that includes global resources that are available to the machine at all levels of operation.

At this layer of the **Next Generation**, the system has access to standard Ethernet and USB, using standard communication protocols such as Ethernet IP/Telnet/Modbus and TCP/IP to communicate with both the machine motion controller and the axis level drives.

The rich communications options supported by the EAS and the modularity inherent in the platform deliver a wide range of functionality. Advanced programming modules offer sophisticated tools that enable tuning the drives according to demanding requirements, configuring the communication protocols and diagnosing and debugging an application while it runs.

The EAS Start Page



The EAS Open a Project Page

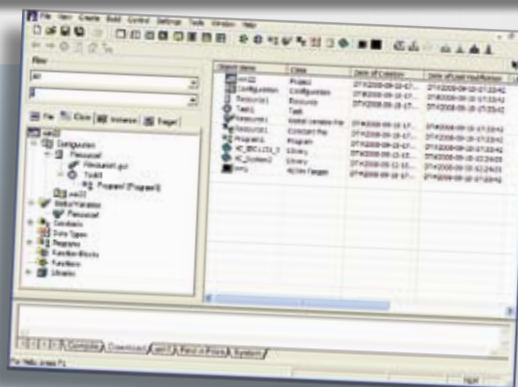

The EAS Advanced Wizard

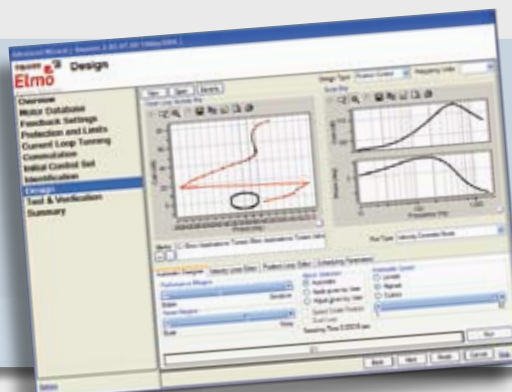

Elmo's Next Generation Solution

One Solution for any Motion Application
One Environment for the Whole Solution

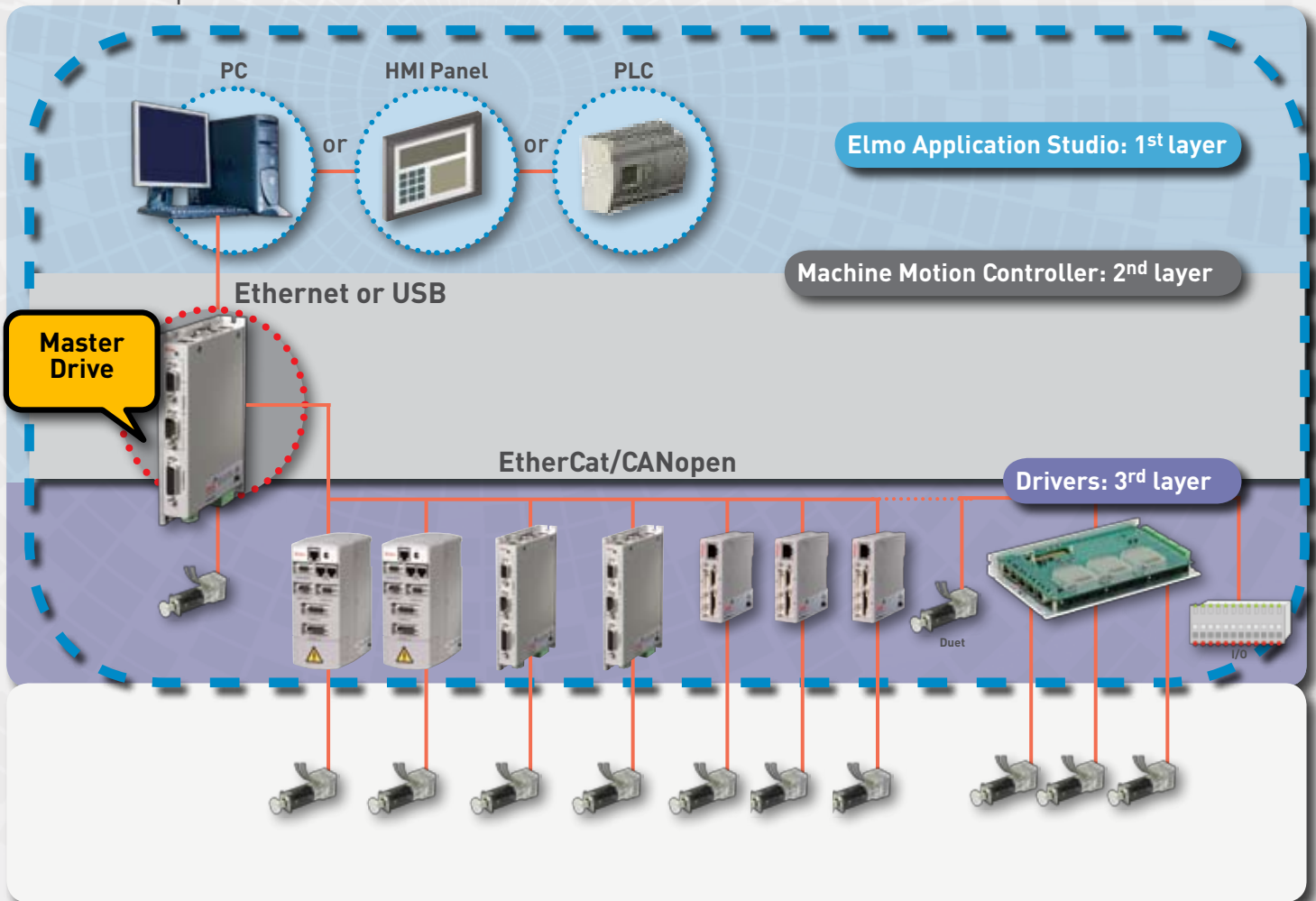

"Go Standard" with Elmo

- IEC 61131-3
- C programming
- Standard communication protocols
- Ready-to-use application templates

The Superior Machine Motion Controller 2nd Layer

The Master Drive – A Drive-Embedded Machine Controller

With Elmo's **Master Drive**, the drive that masters the network, application implementation is simpler and faster. The Master Drive is a super-compact servo drive with advanced capabilities to control all the machine motion over the network. The Master Drive provides an elegant, efficient motion control solution that saves space - no installation, no wiring and no additional power supplies needed. Elmo's machine motion controller is also available as a stand alone unit and as a PCI/ PC card.

This sophisticated, innovative entity adroitly handles:

- Rapid communication with the Elmo Application Studio and end units. EAS data is transmitted via Ethernet or USB. End units, such as servo-drives, I/O cards and other accessories converse over CAN or EtherCAT communication links.
- Precise machine control, such as robust synchronization of up to 16 axes (divided into up to four groups), I/O devices and distributed execution tasks with the machine drive layer.

Elmo's Master Drive machine motion controller is situated with the axis level drives, therefore response and cycle times, as well as communications, are faster, more accurate and more reliable.

The embedded Master Drive is "first among equals" in the drive layer and provides peerless intelligence and fast communication with the Host PC/PLC and the **Next Generation** drive layers. Elmo's innovative approach boosts the intelligence and communication speed to make synchronizing multiple motion axes easy, while reducing the cabling and infrastructure requirements.

Elmo's Next Generation machine motion controller supports IEC61131-3 programming, as well as true C programming and C program execution at the machine motion controller.

Master Drive's Score



The Machine Motion Controller is Available in Three Formats:

1. Master Drive - A Drive Embedded Machine Controller

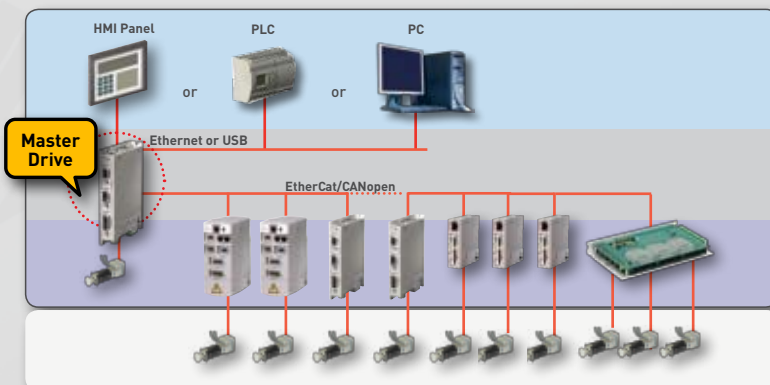

2. Stand Alone Motion Controller

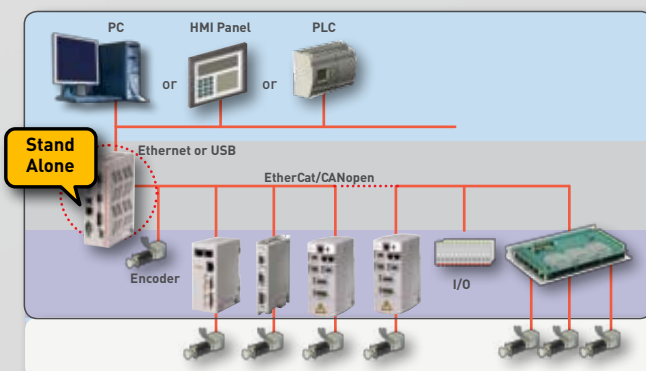

3. Motion Controller Integrated into PCI card

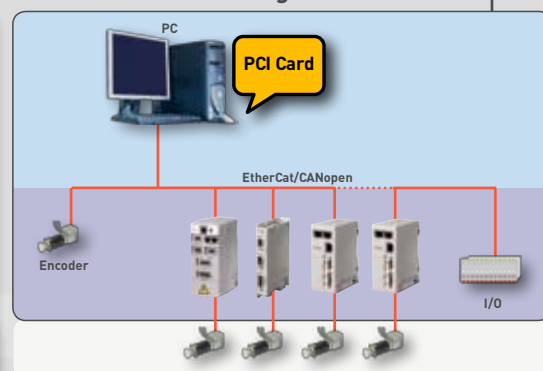

Intelligence at the Axis Level ^{3rd Layer}

With the **Next Generation**, Elmo reaffirms the principle that servo drive performance is essential for the overall result. The **Next Generation** is a significant step forward in the development of Elmo's leading edge servo drives. The evolution of Elmo's **Next Generation** drive layer combines the excellence of the existing servo drive product line with a huge improvement in the motor control and a new emphasis on each drive cooperating as a full partner in a top-level motion network.

The high intelligence built into Elmo's servo drives facilitates the allocation of resource-intensive tasks between the machine motion controller and the drives, thus freeing the system performance from critical communication load and timing issues.

Drive's
Score



Each intelligent, stand alone servo-drive controller can function as a resourceful member of a distributed motion network and enables:

- Multi-tasking programming
- Support for IEC 61131-3 and C programming languages
- Intelligence and fast computing power throughout the motion control system
- Deterministic and faster communication
- Communication and processing load reductions
- The highest power density coupled with top reliability and efficiency

The **Next Generation** is the hot contender in the integrated network-based motion control arena. Elmo's new solution offers three layers that cover all the motion control basics and synergize to provide you with a dynamic solution that is much more than its components. The **Next Generation** includes:

- Top programming platforms, an extensive line-up of versatile templates and tools to create and manage motion applications.
- A wide range of network and automation control protocols.
- Supreme processing power in all three layers to ensure distributed intelligence and independent motion capabilities.

To streamline the design, implementation and management of your motion applications and ensure smooth control for your motion operations, move up to the next level:

Elmo's Next Generation

One Solution for any motion application

One Environment for the whole solution

Elmo's Next Generation Advantages

Elmo Application Studio (The EAS)	
Features	Benefits
<p>Standard development environment and programming languages:</p> <ul style="list-style-type: none"> Windows-based PC development studio IEC 61131-3 compliant C programming 	<p>Unified environment to control all the elements in your motion application.</p> <ul style="list-style-type: none"> Designed for easy, intuitive operation at all levels Uses familiar interfaces, syntax and protocols Design and manage projects on standard platforms Integrated with Elmo's proprietary tools
<ul style="list-style-type: none"> Distributed execution tasks between the Master Drive machine motion controller and drives Multi-tasking programming environment and project execution 	Faster response and cycling time
<ul style="list-style-type: none"> A large selection of completely modular programming resources and tools for: <ul style="list-style-type: none"> Set up Tuning Monitoring Recording and logging 	<ul style="list-style-type: none"> Each module can be used independently You can obtain the modules you need from Elmo as stand-alone program components
Elmo Application Studio Navigation System	Simplifies the programming for the most common motion applications and makes it easy to customize and manage the system to suit your application requirements.
<p>Communication channels and protocols:</p> <ul style="list-style-type: none"> Ethernet 10/100 Base T, USB 2.0 TCP/IP, Telnet 	Greater communication flexibility and compliance.

The Superior Machine Motion Controller	
Features	Benefits
<p>Powerful processing platform that can be incorporated in most Next Generation servo controller drives to create a Master Drive machine motion controller.</p> <ul style="list-style-type: none"> PowerQUICC II Pro Processor 333 MHz Double precision floating point hardware Real Time Linux operating system 	<p>Powerful, programmable, fast, deterministic multi-axis control, embedded in a specialized servo-drive to streamline your logistics.</p> <p>The drive-embedded Master Drive Machine Motion Controller:</p> <ul style="list-style-type: none"> Eliminates the need for a separate controller Enables motion controller integration into projects with high density layout requirements Speeds network communication between motion controller and drives Saves space in the hardware layout: Reduces the amount of system hardware and cabling and infrastructure requirements
<ul style="list-style-type: none"> Full standard implementation of IEC 61131-3 and C programming languages Precise time management mechanisms and advanced control algorithms. 	<p>Superior control and management for:</p> <ul style="list-style-type: none"> Total machine motion and logic control Peripheral components (motion controllers, I/O modules) Executing sequential and deterministic user programs Executing time-based (deterministic) multi-axis motion using motion modes such as ECAM, PVT, 2-3 dimensional spatial trajectory Running and activating deterministic, time-based I/O modules
<p>Support for a wide range of standard environments, communication, channels and protocols:</p> <ul style="list-style-type: none"> Host communications: Ethernet 10/100 Base T, USB 2.0. Supports TCP/IP, Ethernet IP, Telnet and Modbus Drive communications: EtherCAT Master, CAN Support for CANopen and Ethernet over EtherCAT 	<p>Greater communication flexibility and compliance. Standard CANopen or EtherCAT for demanding applications.</p>
<p>Mounting and installation options:</p> <ul style="list-style-type: none"> Stand alone, OEM-oriented packaging PCB mounted component 	<p>Greater hardware packaging flexibility, for more efficient, faster and cost effective installations.</p>

Next Generation Drives	
Features	Benefits
<p>Powerful new processing platform with reduced current, velocity and position loop sample times:</p> <ul style="list-style-type: none"> Current loop performance reduced to 40 µs Velocity and position loop reduced to 80 µs <p>Communication channels:</p> <ul style="list-style-type: none"> TCP/IP and USB protocols for setup and maintenance Ethernet and CAN or EtherCAT(Slave) CANopen (over CAN & EtherCAT): DS402, DS305 & DS301 	<p>The evolution of Elmo's high performance servo-drives brings you an improved processing core and faster communication channels</p> <p>Up to eight times more processing power: Advances in functionality:</p> <ul style="list-style-type: none"> Improved sensor and control algorithm Higher resolution in all aspects (profiler, control...) Faster response time (control, background, I/Os, communication...) Wider range in most of the motion parameters (Speed, Acceleration...) More motion mode options that support PLCopen and time-dependent motion, including PAVT, final speed PTP... Support for a wide range of pure absolute encoders Wider range of feedback options Improved recording: Indications, internal data storage Flexible, standard-compliant, fast communication options Support for CANopen and TCP stacks Hardware time tag for each message in every EtherCAT slave Practical network synchronization jitter over EtherCAT << 1 µs
<p>The servo drive is available as a smart component that can be integrated in the customer's application or as a stand alone device.</p> <p>Extended features available on request:</p> <ul style="list-style-type: none"> Integrated motors and servo drives (Duet products) I/O Cards for I/Os extensions Third party end units, supporting CANopen or EtherCAT 	Configuration flexibility

Head Office

Elmo Motion Control Ltd.
64 Gissin St., P.O. Box 463
Petach Tikva 49103
Israel
Tel: +972 (3) 929-2300
Fax: +972 (3) 929-2322
info-il@elmomc.com

North America

Sales & Technical Support Center

Elmo Motion Control Inc.
42 Technology Way Nashua
NH 03060
U.S.A
Tel: +1 (603) 821-9979
Fax: +1 (603) 821-9943
info-us@elmomc.com

Germany

Sales & Technical Support Center

Elmo Motion Control GmbH
Steinkirchring 1
D-78056, Villingen-Schwenningen
Germany
Tel: +49 (0) 7720-85 77 60
Fax: +49 (0) 7720-85 77 70
info-de@elmomc.com

Asia

Sales & Technical Support Center

Elmo Motion Control APAC
#810, Tower Bldg, 769-10
Jayang-dong, Gwangjin-gu, Seoul
Korea
Tel: +82 (2) 456-3183
Fax: +82 (2) 456-3186
info-asia@elmomc.com

www.elmomc.com