

When Every Movement Counts...

PICCOLO

Servo amplifier for brushless motors

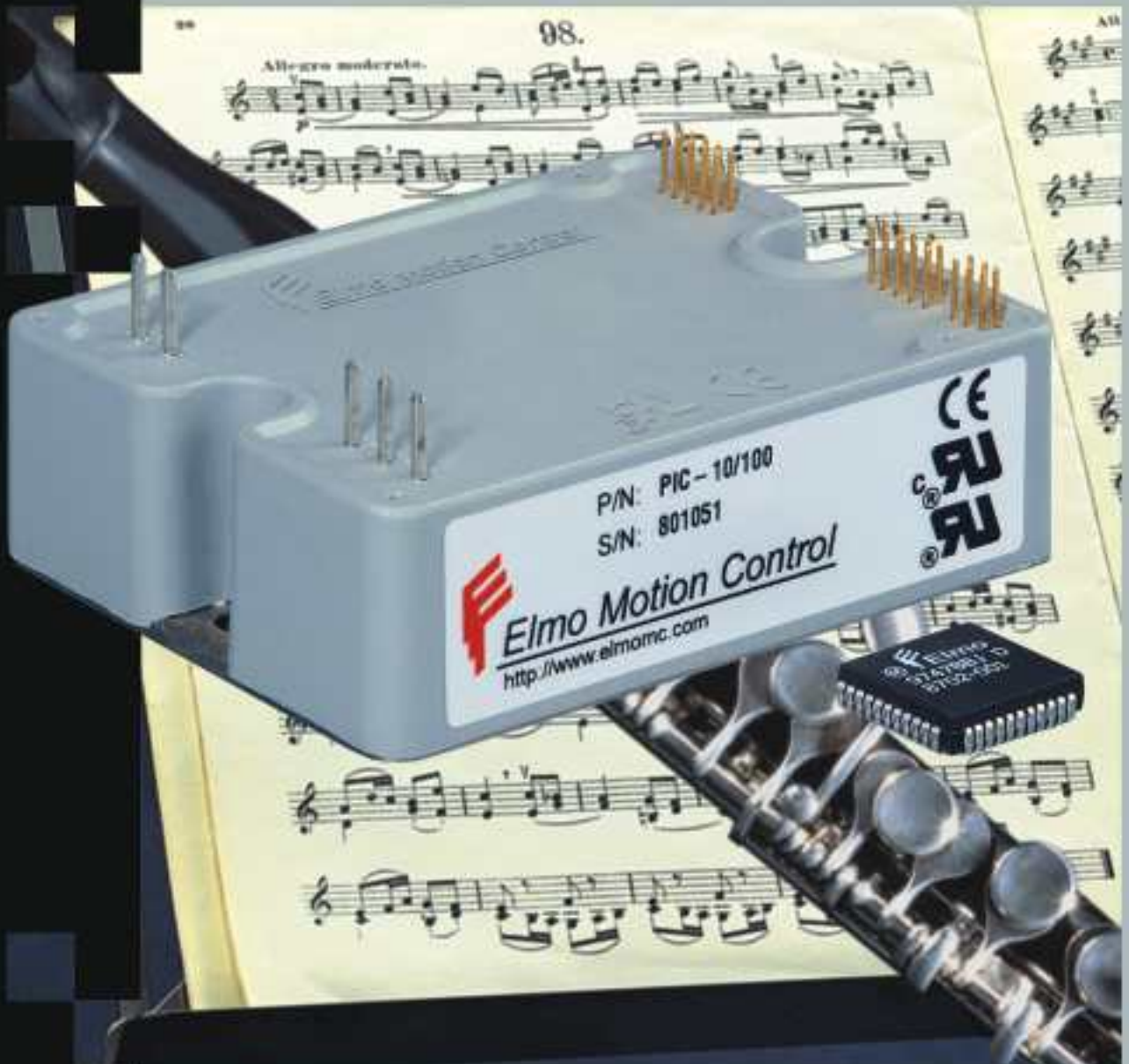

Elmo Motion Control
www.elmomc.com

General Description

The PICCOLO series of miniature servo amplifiers for brushless DC Motors is designed for motion systems where the motor's trapezoidal commutation is performed by the amplifier. The PICCOLO is a trimmerless design for the OEM market and may be mounted directly on the customers PC board as a component. The product meets UL 508c and the relevant CE regulations.

The power stage is implemented on a single ceramic substrate. This design enables very high thermal conductivity, high current carrying capacity, better EMC and good mechanical strength. The control section is implemented by dedicated custom ICs that contribute to higher reliability because fewer components are used and improved performance due to the high level of integration.

Standard Features

- Operation in current mode
- Internal DC to DC converter enables operation from one single supply
- Two differential command reference inputs
- Zero deadband
- Excellent linearity
- External continuous and peak current limit adjustments
- Current feedback multiplier for low current motors
- Remote current gain control
- Enable input
- 3 motor current monitors
- Status indication by 4 open collector opto couplers
- Latch mode of the protective functions
- Ultra-compact size
- Interface via solder pins
- Package: Plated copper base plate, plastic housing, UL94V0 recognized

Optional Features

- High temperature range versions for military and avionics applications are available

Protective Features

- Short between the motor power outputs
- Short between each motor power output and the power input return
- Excess temperature
- Under/Over voltage
- Failure of the internal power supplies

Block Diagram

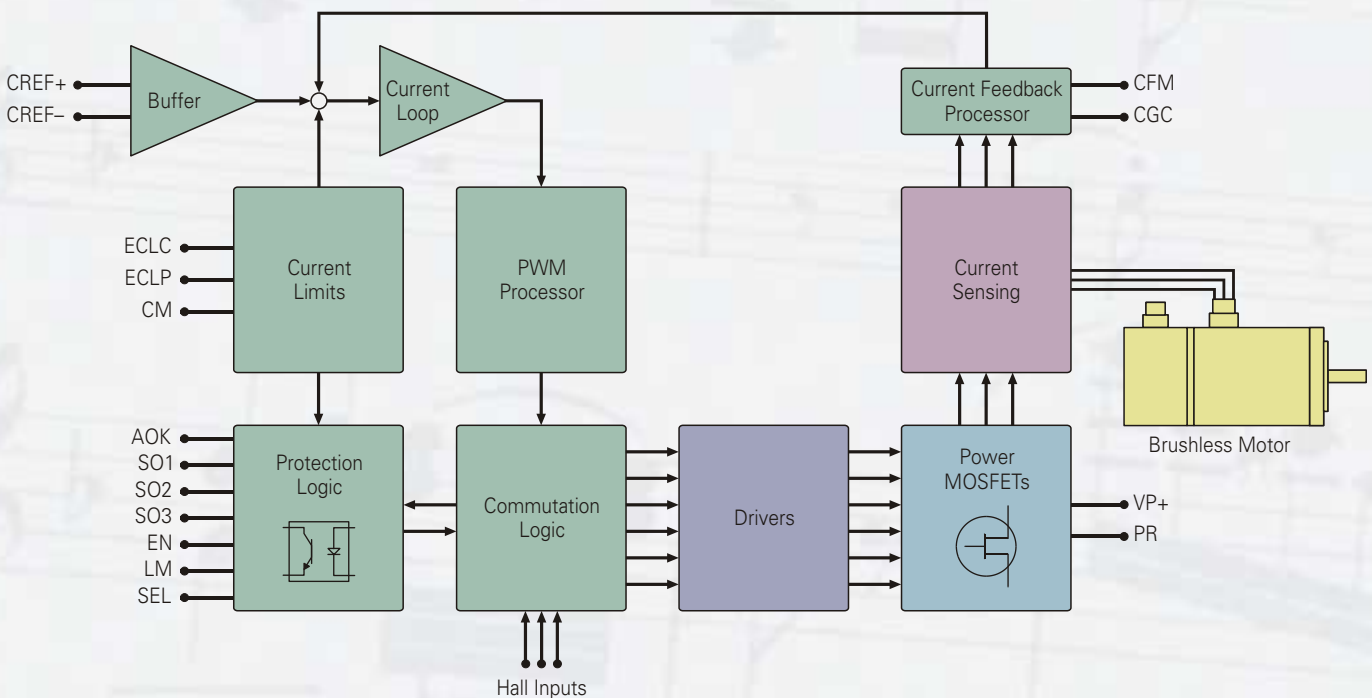

Control Connector J1

Current command input,
External continuous current limit,
External peak current limit,
Current monitor,
Current gain control for low
inductance motors,
Current feedback multiplier for low
current motors

Control Connector J2

Hall sensor format selection,
Latch mode input,
Amplifier enable input,
Amplifier OK indication output,
3 bit status indication output

Power Source

DC power input from a central
isolated power supply or battery
See details on last page

Motor Output

Motor power output phases,
Nominal output current up to 25A,
Peak output current up to 50A

Control Connector J3

Hall sensor connections
Hall sensor supply voltage



Mounting

The unit should be mounted to an external
heat sink for full output power ratings
Max. case temperature 87°C (188°F)

Accessories

PIC-STARTER

The PIC-STARTER is a special interface board designed to facilitate a fast startup and evaluation of the PICCOLO. This add on board includes screw type terminals for all connections, as well as four status LED's and sockets for current limiting and input scaling resistors. DIP switches are provided to enable the user to quickly select amplifier functions. The power pins must be soldered while the signal pins simply plug in. The starter board has the same footprint as the PICCOLO providing the convenience of DIP switches, yet still allowing the user to externally influence all the control functions.



PIC-VELOCITY

The PIC-VELOCITY extends the PICCOLO line by adding a velocity loop daughter board. The PIC-VELOCITY permits operation in current or velocity mode. Velocity mode can utilize either encoder or Hall sensor feedback. The PIC-VELOCITY incorporates forward and reverse limit switch inputs, a full array of diagnostic LED's and additional capacitance on the DC bus. DIP switches are provided for selecting functions such as CGC, CFM, Latch mode, directional limits and amplifier enable. It also includes socketed components for adjusting continuous and peak current limits, command scaling, feedback scaling and velocity loop tuning.



