Flute Installation Guide



April 2008 (Ver. 2.2)



www.elmomc.com

Important Notice

This guide is delivered subject to the following conditions and restrictions:

- This guide contains proprietary information belonging to Elmo Motion Control Ltd. Such information is supplied solely for the purpose of assisting users of the Flute servo amplifier.
- The text and graphics included in this manual are for the purpose of illustration and reference only. The specifications on which they are based are subject to change without notice.
- Information in this document is subject to change without notice. Corporate and individual names and data used in examples herein are fictitious unless otherwise noted.

Doc. No. MAN-FLUIG
Copyright © 2008
Elmo Motion Control Ltd.
All rights reserved.

Flute Catalog Number	<p style="text-align: center;">FLU-XX/YYY</p> <p style="text-align: center;">└───┬───┘</p> <p style="text-align: center;">Continuous Maximum Output Operating Current Voltage</p>
----------------------	--

Revision History

- Ver. 2.2** April 2008 Updated Power Ratings Table in Appendix
- Ver. 2.1** Aug. 2004 50 and 55 VDC models upgraded to 60 VDC models
- Ver. 2.0** May 2003 Manual name revised to *Flute User Guide* and look updated
- Ver. 1.0** May 1999 Initial release of *FLU Series Installation and Operating Manual*

Elmo Motion Control Ltd. 64 Gisin St., P.O. Box 463 Petach Tikva 49103 Israel Tel: +972 (3) 929-2300 Fax: +972 (3) 929-2322 info-il@elmomc.com	Elmo Motion Control Inc. 1 Park Drive, Suite 12 Westford, MA 01886 USA Tel: +1 (978) 399-0034 Fax: +1 (978) 399-0035 info-us@elmomc.com	Elmo Motion Control GmbH Steinkirchring 1 D-78056, Villingen-Schwenningen Germany Tel: +49 (0) 7720-85 77 60 Fax: +49 (0) 7720-85 77 70 info-de@elmomc.com	 www.elmomc.com
--	---	--	---

Contents

Chapter 1: Safety Information	1-1
1.1 Warnings.....	1-2
1.2 Cautions	1-2
1.3 Conformance to Standards.....	1-3
1.4 Warranty Information.....	1-3
Chapter 2: Introduction.....	2-1
2.1 Product Description	2-1
2.2 Standard Features	2-1
2.3 Fault Protection	2-1
2.4 How to Use this Guide	2-3
Chapter 3: Installation	3-1
3.1 Site Requirements.....	3-1
3.2 Unpacking the Amplifier Components.....	3-1
3.3 Flute Dimensions.....	3-2
3.4 Mounting the Flute	3-3
3.4.1 Mounting the Heatsink	3-3
3.4.2 Mounting on the PC Board	3-3
3.5 Wiring the Flute.....	3-4
3.6 Connections	3-4
3.6.1 Pin Functions.....	3-4
3.6.2 Connecting a Non-isolated Flute to an Isolating Power Transformer.....	3-7
3.7 DC Power Supply.....	3-8
Chapter 4: Servo Control Operation	4-1
4.1 Current Command Input.....	4-1
4.2 CFM	4-1
4.3 Current Gain Control (CGC).....	4-2
4.4 External Current Limit - Continuous (ECLC)	4-3
4.4.1 External Voltage.....	4-3
4.4.2 External Resistor	4-3
4.5 External Current Limit - Peak (ECLP).....	4-3
4.5.1 External Voltage.....	4-3
4.5.2 External Resistor	4-4
4.6 Latch Mode (LM).....	4-4
4.7 Amplifier Enable Logic.....	4-4
4.8 Status Indications	4-5
Appendix: Technical Specifications	A-1
A.1 Power Ratings.....	A-1
A.2 Electrical Specifications	A-1
A.3 Mechanical Specifications.....	A-2
A.4 Environmental Conditions	A-2

Chapter 1: Safety Information

In order to achieve the optimum, safe operation of the Flute servo amplifier, it is imperative that you implement the safety procedures included in this user guide. This information is provided to protect you and to keep your work area safe when operating the Flute and accompanying equipment. Read this chapter carefully before you begin the installation process.



Ensure that all system components are connected to earth ground. Electrical safety is provided through a low-resistance earth connection.

Only qualified personnel may install, adjust, maintain and repair the servo amplifier. A “qualified person” has the knowledge and authorization to perform tasks such as transporting, assembling, installing, commissioning and operating motors.





The Flute servo amplifier contains electrostatic-sensitive components that can be damaged if handled incorrectly. To prevent any electrostatic damage, avoid contact with highly insulating materials, such as plastic film and synthetic fabrics. Place the product on a conductive surface and ground yourself in order to discharge any possible static electricity build-up.

To avoid any potential hazards that may cause severe personal injury or damage to the product during operation, keep all covers and cabinet doors shut.



The following safety symbols are used in this manual:

	Warning: This information is needed to avoid a safety hazard, which might cause bodily injury.
	Caution: This information is necessary for preventing damage to the product or to other equipment.
	Note: This is auxiliary information that ensures the correct operation of the equipment.

1.1 Warnings

	<p>Cleaning after soldering</p> <p>To avoid the damage of the product's acrylic coating the Flute must not be cleaned after soldering by dissolving solvents and /or "water" cleaning process. For more details: http://www.elmomc.com/applications/article/Soldering-and-Cleaning_Application-Note.pdf</p>
	<p>To avoid electric arcing and hazards to personnel and electrical contacts, never connect/disconnect the servo amplifier while the power source is on.</p>
	<p>Power cables can carry a high voltage, even when the motor is not in motion. Disconnect the Flute from all voltage sources before it is opened for servicing.</p>
	<p>After shutting off the power and removing the power source from your equipment, wait at least 5 minutes before touching or disconnecting parts of the equipment that are normally loaded with electrical charges (such as capacitors or contacts). Measuring the electrical contact points with a meter before touching the equipment is recommended.</p>

1.2 Cautions

	<p>The Flute servo amplifier contains hot surfaces and electrically-charged components during operation.</p>
	<p>The maximum DC power supply connected to the instrument must comply with the parameters outlined in this guide.</p>

1.3 Conformance to Standards

The Flute servo amplifier has been developed, produced, tested and documented in accordance with the relevant standards. Elmo Motion Control is not responsible for any deviation from the configuration and installation described in this documentation. Furthermore, Elmo is not responsible for the performance of new measurements or ensuring that regulatory requirements are met.

The Flute servo amplifier is intended for incorporation in a machine or end product. The actual end product must comply with all safety aspects of the relevant requirements of the European Safety of Machinery Directive 89/392/EEC as amended, and with those of the most recent versions of standards EN60204-1 and EN292-2 at the least.

According to Annex III of Article 13 of Council Directive 93/68/EEC, amending Council Directive 73/23/EEC concerning electrical equipment designed for use within certain voltage limits, the Flute meets the provisions outlined in Council Directive 73/23/EEC. The party responsible for ensuring that the equipment meet the limits required by EMC regulations is the manufacturer of the end product.

1.4 Warranty Information

The products covered in this manual are warranted to be free of defects in material and workmanship and conform to the specifications stated either within this document or in the product catalog description. All Elmo amplifiers are warranted for a period of 12 months from the time of installation, or 18 months from time of shipment, whichever comes first. No other warranties, expressed or implied — and including a warranty of merchantability and fitness for a particular purpose — extend beyond this warranty.

Chapter 2: Introduction

This user guide is intended for the design engineer who is integrating an Elmo Motion Control Flute servo amplifier into a machine.

2.1 Product Description

The Flute series of miniature servo amplifiers is designed for brushless motors in which sinusoidal commutation is performed by the motion controller. The amplifier accepts two current commands from the motion controller and internally processes the third phase current requirement to produce a balanced three-phase configuration. The basic configuration is a current mode amplifier targeting the OEM market. As such, it has no trimmers and is installed directly on the customer's PCB like any other component. The Flute amplifier meets UL508c and the relevant CE regulations.

The Flute power stage is implemented on a single ceramic substrate. This design enables very high thermal conductivity, high current carrying capacity, improved EMC and good mechanical strength. The control section is implemented by dedicated custom ICs that contribute to higher reliability resulting from fewer components, and enhanced performance due to the amplifier integration.

2.2 Standard Features

- Operation in current mode
- Internal DC-to-DC converter, which allows for operation from a single supply
- Zero deadband
- Excellent linearity
- One differential input
- Motor current monitor
- Current gain change for low inductance motors
- Remote current gain control
- Current feedback multiplier for low current motors
- Status indication and remote control functions by four open collector transistors
- External continuous and peak current-limit adjustments
- Interface via soldering pins
- Package: plated-copper base plate, plastic housing, UL94V0 recognized
- Ultra-compact size

2.3 Fault Protection

Built-in protection against possible fault conditions, including:

- Shorts between the outputs or between each output and the power input/return
- Over-temperature
- Under/over voltage
- Failure of internal power supplies
- Latch mode for each protective feature

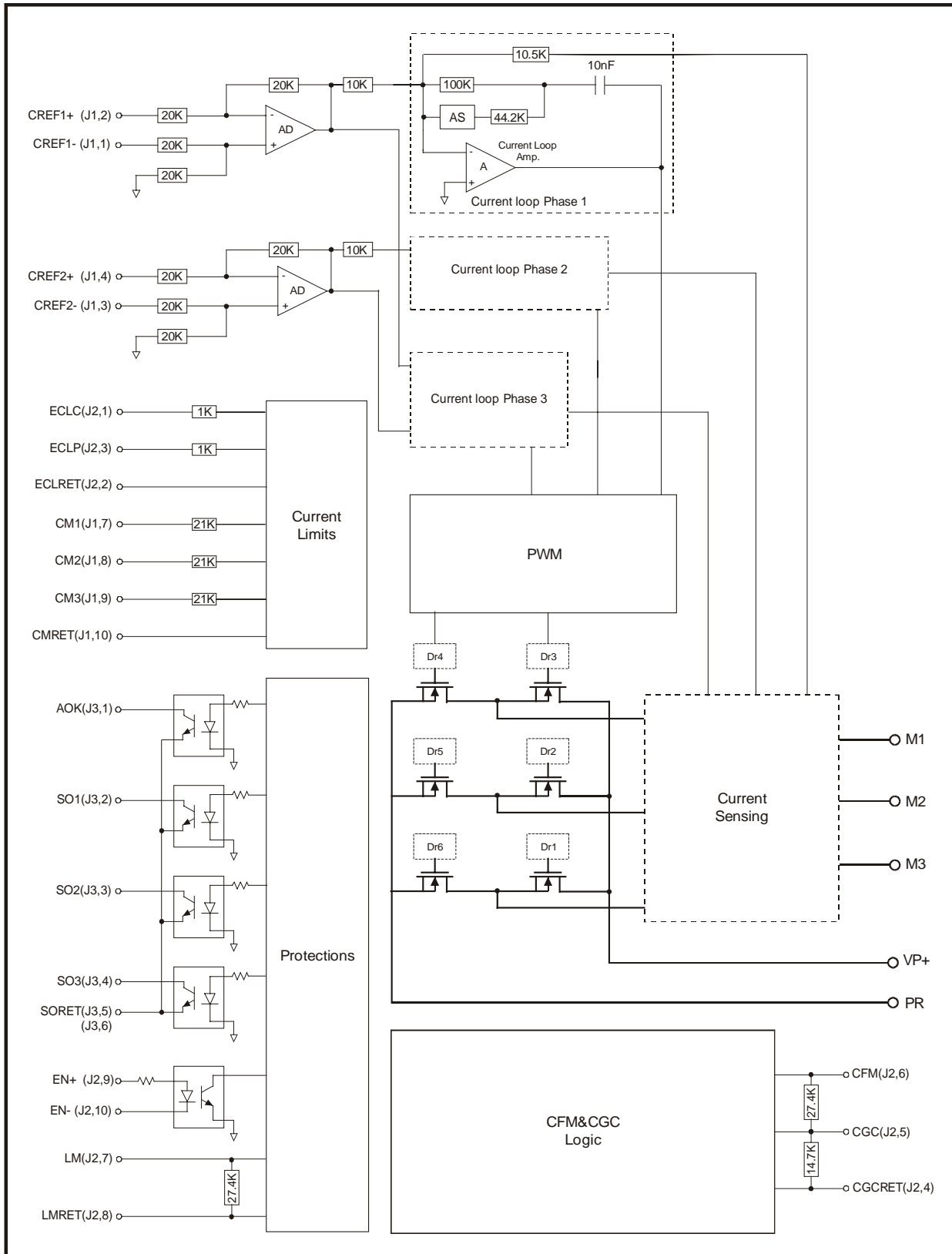

Figure 2-1: Flute Block Diagram

2.4 How to Use this Guide

Installation is the first step in integrating and operating the Elmo Flute servo amplifier. After carefully reading the safety instructions in the first chapter, the following chapters provide you with installation instructions as follows:

[Chapter 3, *Installation*](#), provides step-by-step instructions for unpacking, mounting and connecting the Flute.

[Chapter 4, *Servo Control Operation*](#), explains how to control the operation of the servo amplifier.

The [Appendix, *Technical Specifications*](#), lists all the drive ratings and specifications.

Chapter 3: Installation

3.1 Site Requirements

You can guarantee the safe operation of the Flute by ensuring that it is installed in an appropriate environment.

Feature	Value
Ambient operating temperature	0 °C - 50 °C (32 °F - 122 °F)
Maximum case temperature	87 °C (188 °F)



Note: Models for extended environmental conditions are available.

3.2 Unpacking the Amplifier Components

To unpack the Flute:

Carefully remove the servo amplifier from the box and the Styrofoam.

1. Check the amplifier to ensure that there is no visible damage to the instrument. If any damage has occurred, report immediately to the carrier that delivered your amplifier.
2. To ensure that the Flute you have unpacked is the appropriate type for your requirements, find the part number sticker on the side of the Flute:

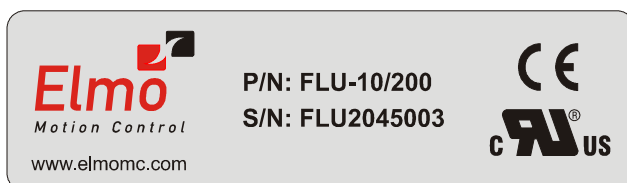

FLU0022A

The P/N number at the top gives the type designation as follows:

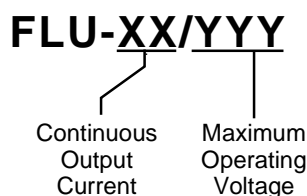

3. Verify that the Flute type is the one that you ordered, and ensure that the voltage meets your specific requirements.

3.3 Flute Dimensions

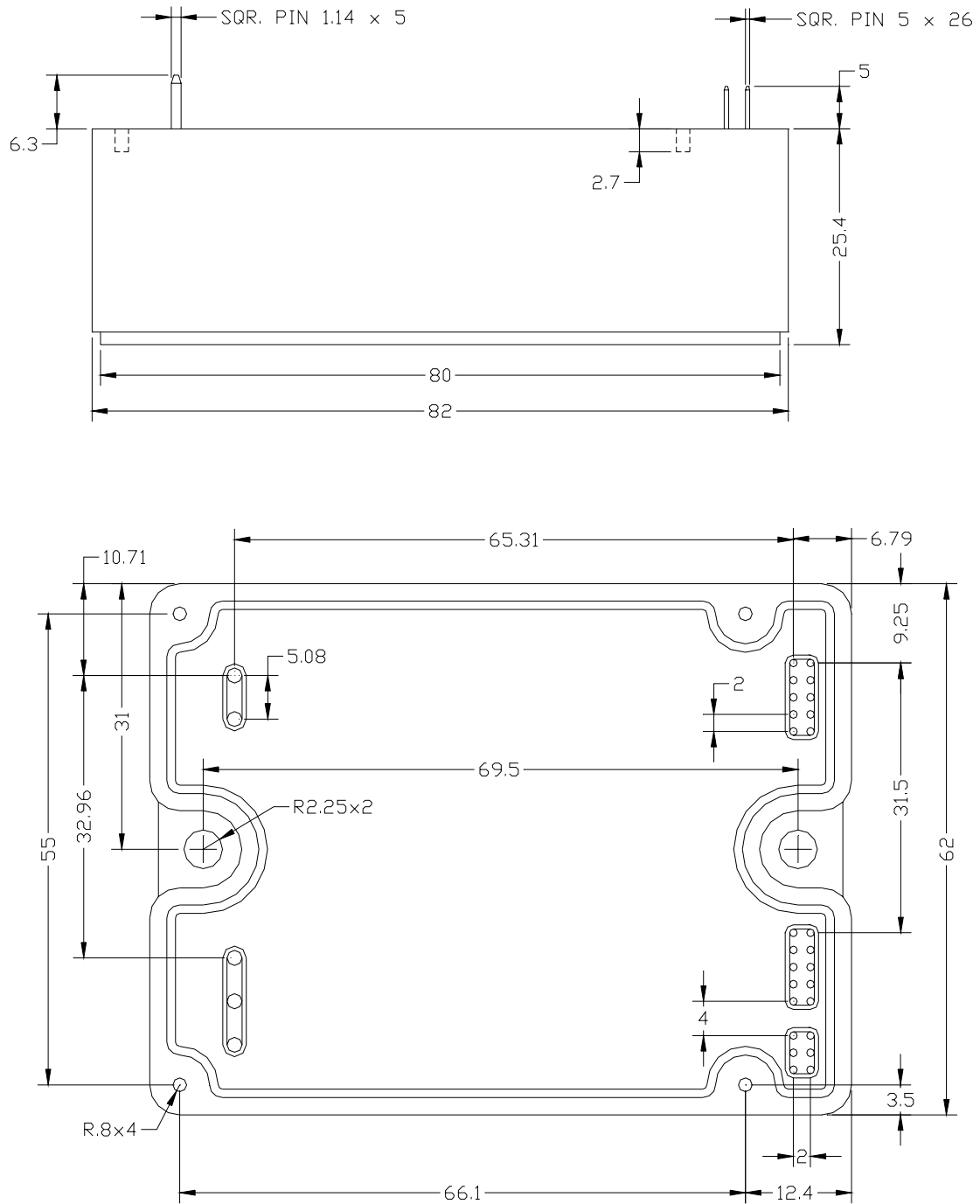

Figure 3-1: Flute Dimensions

3.4 Mounting the Flute

3.4.1 Mounting the Heatsink

The Flute dissipates its heat by natural convection, up to loads of 500 W. For higher output loads, the amplifier should be mounted on an additional heatsink or cooled by fan. There are two 4.5-mm holes in the base plate for mounting an additional heatsink (see Figure 3-1).

3.4.2 Mounting on the PC Board

When mounting the Flute on a PC board, four screws (in addition to the solder pins) may be installed to provide a mechanical connection. It is important to provide a spacer if any components are located above the amplifier. Failure to do so can warp the PC board or puncture the amplifier case. When selecting screws, the following specifications should be used. If a spacer has been added, the screw length must be calculated to penetrate the case by no more than 2.6 mm.

Screw Type: Phillips Pan Head Self-tapping (for plastic) screw – Nickel-plated Steel.
 Meets standards ISO 1478, EN 21478, or DIN 7970.

d	ST2.2
L	4.5*
P	0.8
d _k	4.2
k	1.8
m _≈	2.6
Phillips size	1

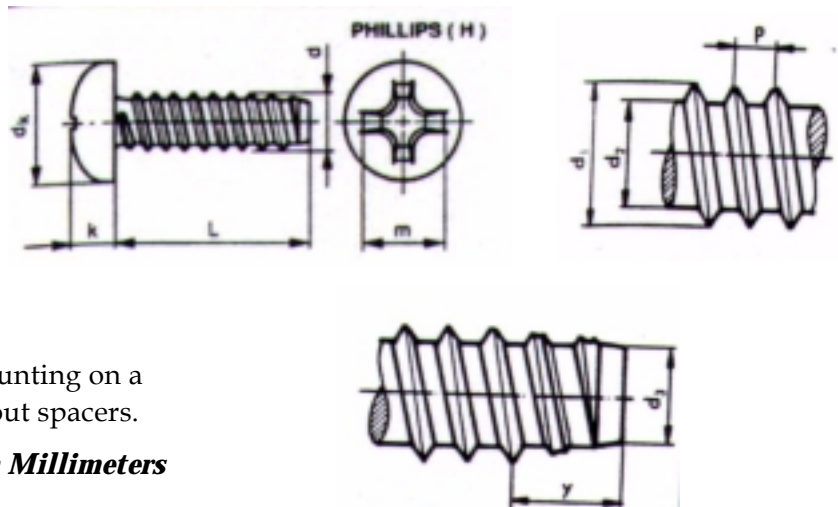

*4.5 mm is typical for mounting on a PC board assembly without spacers.

Table 3-1: Dimensions in Millimeters

Basic Diameter	ISO Nr.	Pitch P	Main Diameter		Minor Diameter		Flat End Diameter	
			D _{1max}	D _{1min}	D _{2max}	D _{2min}	D _{3max}	D _{3min}
ST2.2	2	0.8	2.24	2.1	1.63	1.52	1.47	1.37

Table 3-2: Size Limits for Tapping Screw Thread

3.5 Wiring the Flute

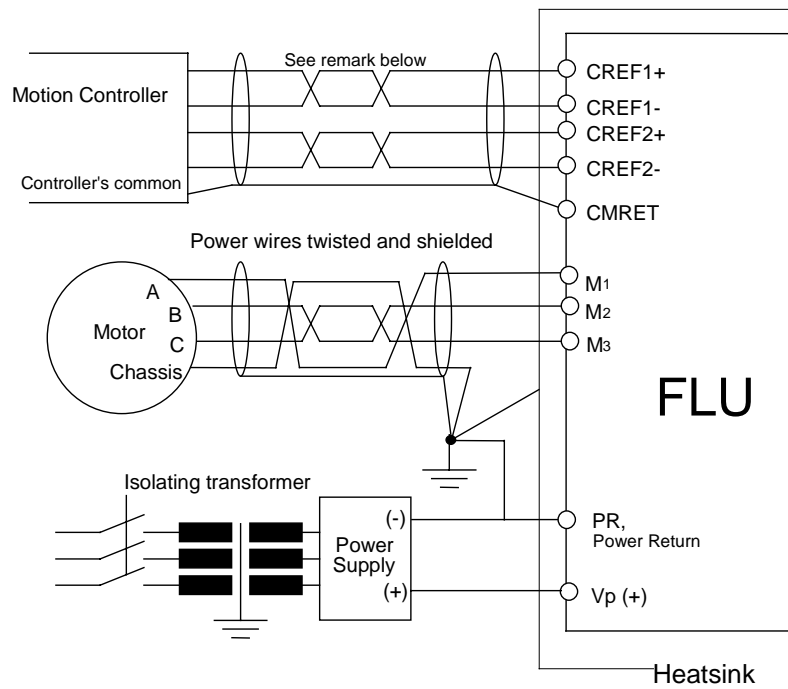

The controller common must be connected to the CMRET whenever the common mode difference is over 6V.

Figure 3-2: Basic Wiring

3.6 Connections

3.6.1 Pin Functions

The Flute connections are described in the following figure and tables.

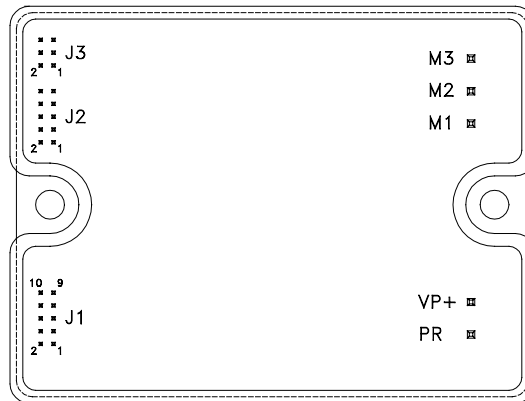

Figure 3-3: Flute Connector Locations

Pin	Function	Remarks
VP+	Positive power input	
PR	Power input return	
M ₁	Motor power output 1	
M ₂	Motor power output 2	
M ₃	Motor power output 3	

Table 3-3: Flute Power Connections

Pin #/ Short Form	Function	Remarks
1 CREF1-	Current command input (-)	Negative input of a differential amplifier: <ul style="list-style-type: none"> ▪ Input operating voltage range: ± 3.75 V ▪ Maximum input voltage: ± 20 V (see section 4.1) ▪ Maximum common mode voltage: ± 6 V (referred to as CMRET) ▪ Differential input impedance: 40 kΩ
2 CREF1+	Current command input (+)	Positive input of a differential amplifier. Specification as for pin J1/1.
3 CREF2-	Current command input (-)	Negative input of a differential amplifier. Specification as for pin J1/1.
4 CREF2+	Current command input (+)	Positive input of a differential amplifier. Specification as for pin J1/1.
5	N/C	
6	N/C	
7 CM1	Current monitor for M1	Analog output with a scale of ± 3.9 V for $\pm I_p$. <ul style="list-style-type: none"> ▪ Output resistance: 21 kΩ
8 CM2	Current monitor for M2	Analog output with a scale of ± 3.9 V for $\pm I_p$. <ul style="list-style-type: none"> ▪ Output resistance: 21 kΩ
9 CM3	Current gain change return	Analog output with a scale of ± 3.9 V for $\pm I_p$. <ul style="list-style-type: none"> ▪ Output resistance: 21 kΩ
10 CMRET	Current monitor return	Return for the current monitor (CM) signals.

Table 3-4: Connector J1

Pin #/ Short Form	Function	Remarks
1 ELCL	External current limit - continuous	External voltage scales down rated value. <ul style="list-style-type: none"> ▪ Voltage range: 0 V to 3.75 V (3.75 V = rated Ic) ▪ Internally limited to rated value
2 ECLRET	Current limits return	Return for current limits signals.
3 ECLP	External current limit - peak	External voltage scales down rated value. <ul style="list-style-type: none"> ▪ Voltage range: 0 V to 3.75 V (3.75 V = rated Ip) ▪ Internally limited to rated value
4 CGCRET	Current gain change return	Return for CGC signal.
5 CGC	Current gain change	Shorting this pin to the CGCRET pin (J2/4) reduces the proportional gain (P) of the current loop by 70%.
6 CFM	Current feedback multiplier	Shorting this pin to pin J2/5 (CGC) multiplies the current feedback signal by 2.
7 LM	Latch mode	Latch mode input.
8 LMRET	Latch mode return	Return for Latch mode (LM).
9 EN+	Enable (+)	Positive voltage input of "Amplifier Enable" function. To enable operation of the amplifier, the opto must be switched on by applying voltage between this pin (+) and pin J2/10 (-). The opto is isolated from the amplifier. See Figure 2-1 . <ul style="list-style-type: none"> ▪ Minimum "On" voltage: 3 V , current consumption 0.6 mA. ▪ Maximum "On" voltage: 15 V , current consumption 5.4 mA.
10 EN-	Enable (-)	Negative voltage input of "Amplifier Enable" function. Opto is isolated from the amplifier. For details, see pin J2/9.

Table 3-5: Connector J2

Pin #/ Short Form	Function	Remarks
1 AOK	Amplifier OK	<p>“Amplifier OK” indication output pin. When the amplifier is at normal operating conditions, this output is in “active low “ state. When a failure occurs, this output is changed to “open” state. Opto isolated, open collector NPN type. See Figure 2-1.</p> <ul style="list-style-type: none"> ▪ Maximum voltage = 30 V ▪ Maximum current = 8 mA. ▪ “On” voltage: $V_{OUT(On)} < 0.8 V$
2 SO1	Status output 1	Status indication output 1. Specification as in pin J3/1.
3 SO2	Status output 2	Status indication output 2. Specification as in pin J3/1.
4 SO3	Status output 3	Status indication output 3. Specification as in pin J3/1.
5 SORET	Status output return	Status output return for AOK, SO1, SO2, SO3. Isolated from power input return. for details, see Figure 2-1 .
6 SORET	Status output return	Status output return for AOK, SO1, SO2, SO3. Isolated from power input return. for details, see Figure 2-1 .

Table 3-6: Connector J3

3.6.2 Connecting a Non-isolated Flute to an Isolating Power Transformer

Be sure to ground:

- DC power common
- Motor chassis
- Amplifier heatsink

Do not ground the control common, which is internally connected to the power common. Grounding the control common will create a ground loop.

3.7 DC Power Supply

The DC power supply can be at any voltage in the range defined in the technical specifications ([Appendix](#) of this guide). The supply source must comply with the safety aspects of the relevant requirements, in accordance with the most recent version of the standard EN60950 or equivalent Low Voltage Directive Standard, all according to the applicable over-voltage category. If the power source to the power supply is the AC line (through a transformer), safety margins must be considered, in order to avoid activating the under/over voltage protection due to line variations and/or voltage drop under load.

In addition to the above, the transformer must comply with the safety aspects of the relevant requirements in accordance with the most recent version of the standard EN60742 (Isolating and Safety Isolating Transformers). The nominal DC bus voltage should be in the following range:

$$1.2 V_{dcmin} < V_{dc} < 0.9 V_{dcmax}$$

where:

V_{dcmin} is the minimum DC bus

V_{dcmax} is the maximum DC bus

The recommended minimum power supply capacitance for single-phase connections is as follows:

Amplifier Voltage Range	50 - 55 V	100 V	200 V
Recommended capacitance	5600 μ F	3300 μ F	1500 μ F

The transformer power should be calculated such that it will be able to deliver power to the amplifier (including peak power) without significant voltage drops.

The power supply should be located as close as possible to the amplifier. The maximum distance is 30 cm (1 foot). While driving high-inertia loads, the power supply must be equipped with a shunt regulator; otherwise, the amplifier will be disabled whenever the capacitors are charged above the maximum voltage.

Chapter 4: Servo Control Operation

4.1 Current Command Input

The Flute has two differential inputs. The input operating voltage range is ± 3.75 V, meaning that a 3.75 V signal will result in a fully rated peak current. The current limit circuits will override this signal if the peak duration exceeds 2.7 seconds and/or the required current exceeds the values set by the ECLC and ECLP signals. If the input command voltage exceeds 3.75 V, input scaling must be implemented by adding a pair of external resistors, according to the following formula:

$$R_{in} (K\Omega) = (5.33 * V_{in}) - 20$$

Be careful not to apply input voltage above the maximum allowed input voltage as this will cause the input operational amplifier to operate beyond its limits (± 20 V) and in extreme cases, may even damage it.

4.2 CFM

The amplifier is equipped with a current feedback multiplier (CFM). Connecting pin J2/6 to J2/5 multiplies the signal of the current feedback by 2 and consequently causes the following changes to occur:

- Current gains are divided by 2.
- Current monitor is multiplied by 2.
- Current limits are divided by 2.

This function should be activated whenever the rated current *and* the peak current of the motor are less than 50% of the amplifier rated continuous and peak limits, respectively.

	Continuous Current limit	Peak Current Limit	Current Gain(A/V)	Current Monitor (V/A)	Differential Input Impedance
Without CFM	Ic	Ip	Ip/3.75	3.9/Ip	40 kΩ
With CFM	Ic/2	Ip/2	Ip/7.5	7.8/Ip	40 kΩ

Table 4-1: CFM Effects

- The default (pin J2/6 left open) is the low current feedback.
- For permanent selection, a simple short is recommended.
- For remote selection, the scheme in [Figure 4-1](#) should be used.

4.3 Current Gain Control (CGC)

The Flute amplifier is equipped with Current Gain Control (CGC) for improved performance of low inductance motors. Connecting pin J2/5 to J2/4 reduces the gain of the current loop, thus enabling the use of low inductance motors without the insertion of an additional inductor. The default (pin J2/5 left open) is high gain.

Shorting this pin to the circuit common pin (J2/4) reduces the proportional gain (P) of the current loop by approx. 70%.

For permanent selection, a simple short is recommended. For remote selection, the following scheme should be used.

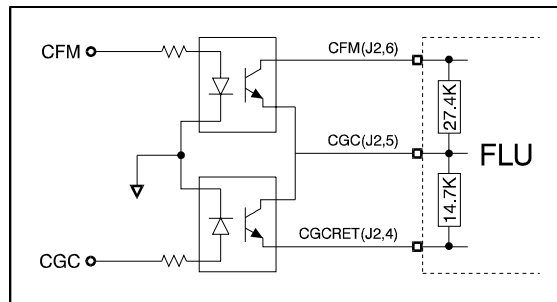

Figure 4-1: CFM and CGC Remote Control

The following table should be used for calculating minimum inductance values.

	Minimum Inductance for High Gain	Minimum Inductance for Low Gain
5/60	$L_{\text{Load (millihenry)}} > 12 \cdot 10^{-3} \cdot V_{\text{supply (Volt)}}$	$L_{\text{Load (millihenry)}} > 4.8 \cdot 10^{-3} \cdot V_{\text{supply (Volt)}}$
10/60	$L_{\text{Load (millihenry)}} > 6 \cdot 10^{-3} \cdot V_{\text{supply (Volt)}}$	$L_{\text{Load (millihenry)}} > 2.4 \cdot 10^{-3} \cdot V_{\text{supply (Volt)}}$
15/60	$L_{\text{Load (millihenry)}} > 4 \cdot 10^{-3} \cdot V_{\text{supply (Volt)}}$	$L_{\text{Load (millihenry)}} > 1.6 \cdot 10^{-3} \cdot V_{\text{supply (Volt)}}$
25/60	$L_{\text{Load (millihenry)}} > 2.4 \cdot 10^{-3} \cdot V_{\text{supply (Volt)}}$	$L_{\text{Load (millihenry)}} > 0.9 \cdot 10^{-3} \cdot V_{\text{supply (Volt)}}$
3/100	$L_{\text{Load (millihenry)}} > 27 \cdot 10^{-3} \cdot V_{\text{supply (Volt)}}$	$L_{\text{Load (millihenry)}} > 6.6 \cdot 10^{-3} \cdot V_{\text{supply (Volt)}}$
10/100	$L_{\text{Load (millihenry)}} > 9 \cdot 10^{-3} \cdot V_{\text{supply (Volt)}}$	$L_{\text{Load (millihenry)}} > 2.2 \cdot 10^{-3} \cdot V_{\text{supply (Volt)}}$
15/100	$L_{\text{Load (millihenry)}} > 6 \cdot 10^{-3} \cdot V_{\text{supply (Volt)}}$	$L_{\text{Load (millihenry)}} > 1.5 \cdot 10^{-3} \cdot V_{\text{supply (Volt)}}$
20/100	$L_{\text{Load (millihenry)}} > 4 \cdot 10^{-3} \cdot V_{\text{supply (Volt)}}$	$L_{\text{Load (millihenry)}} > 1.1 \cdot 10^{-3} \cdot V_{\text{supply (Volt)}}$
2/200	$L_{\text{Load (millihenry)}} > 49.5 \cdot 10^{-3} \cdot V_{\text{supply (Volt)}}$	$L_{\text{Load (millihenry)}} > 12 \cdot 10^{-3} \cdot V_{\text{supply (Volt)}}$
6/200	$L_{\text{Load (millihenry)}} > 16.5 \cdot 10^{-3} \cdot V_{\text{supply (Volt)}}$	$L_{\text{Load (millihenry)}} > 4 \cdot 10^{-3} \cdot V_{\text{supply (Volt)}}$
10/200	$L_{\text{Load (millihenry)}} > 10 \cdot 10^{-3} \cdot V_{\text{supply (Volt)}}$	$L_{\text{Load (millihenry)}} > 2.4 \cdot 10^{-3} \cdot V_{\text{supply (Volt)}}$
15/200	$L_{\text{Load (millihenry)}} > 6.5 \cdot 10^{-3} \cdot V_{\text{supply (Volt)}}$	$L_{\text{Load (millihenry)}} > 1.6 \cdot 10^{-3} \cdot V_{\text{supply (Volt)}}$

Table 4-2: Minimum Inductance Values

4.4 External Current Limit - Continuous (ECLC)

The continuous current limit of the Flute amplifier can be scaled down by an external voltage or by an external resistor connected from pin J2/1 (ECLC) to pin J2/2 (ECLRET).

4.4.1 External Voltage

An external positive voltage (0 to 3.75 V) to terminal J2/1 (ECLC) in reference to terminal J2/2 (ECLRET) will control the continuous current limit from zero to $I_{c(nom)}$.

$$I_{c(new)} = \frac{V_{ECLC}}{3.75V} * I_{c(nom)}$$

- The voltage is internally clamped to 3.75 V whenever the external V_{ECLC} is greater than 3.75 V.
- The external voltage source must be able to source/ sink at least ± 0.4 mA.
- The maximum absolute V_{ECLC} is 12 V.

4.4.2 External Resistor

Connect an external resistor between terminal J2/1 (ECLC) and terminal J2/2 (ECLRET). The resistor value is given by:

$$R_{ECLC} \text{ (Kohm)} = 12.5 * \frac{I_{c(new)}}{I_{c(nom)}} - 1$$

- $0 < R_{ECLC} < 11.4$ K (1/8 Watt)
- At R_{ECLC} greater than 11.4 K, the current limit will be internally clamped to the nominal value.
- $I_{c(nom)}$ is the nominal continuous current limit of the amplifier.

4.5 External Current Limit - Peak (ECLP)

The peak current limit of the Flute amplifier can be scaled down by an external voltage or by an external resistor connected between pin J2/3 (ECLP) and pin J2/2 (ECLRET).

4.5.1 External Voltage

An external positive voltage (0 to 3.75 V) to terminal J2/3 (ECLP) in reference to terminal J2/2 (ECLRET) will control the peak current limit from zero to $I_{p(nom)}$.

$$I_{p(new)} = \frac{V_{ECLP}}{3.75V} * I_{p(nom)}$$

- The voltage is internally clamped to 3.75 V whenever the external V_{ECLP} is higher than 3.75 V.
- The external voltage source must be able to source/sink at least ± 0.4 mA.
- The maximum absolute V_{ECLP} is 12 V.

4.5.2 External Resistor

Connect an external resistor between terminal J2/3 (ECLP) and terminal J2/2 (ECLRET). The resistor value is given by:

$$R_{ECLP} \text{ (Kohm)} = 12.5 * \frac{I_p(\text{new})}{I_p(\text{nom})} - 1$$

- $0 < R_{ECLP} < 11.4 \text{ K (1/8 Watt)}$
- At R_{ECLP} greater than 11.4K, the current limit will be internally clamped to the nominal value.
- $I_{P(\text{nom})}$ is the nominal peak current limit of the amplifier.

4.6 Latch Mode (LM)

By connecting J2/7 to J2/8, the amplifier can be latched to Disable mode whenever a Short or Over Temperature failure occurs. Disabling the amplifier temporarily (removing the power from Enable pins J2/9 and J2/10) resets the latch. Be sure to restore the Enable connection when the reason for the event no longer exists. For permanent selection, a simple short is recommended. For remote selection, use the following scheme.

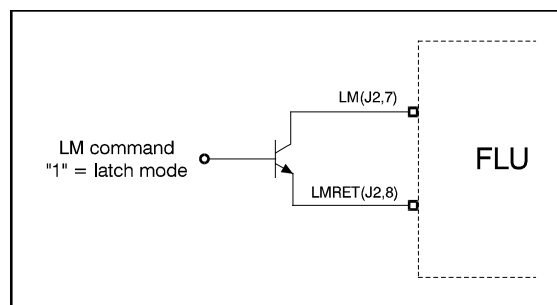

Figure 4-2: LM Remote Control

4.7 Amplifier Enable Logic

Pins J2/9 and J2/10 are the inputs of an opto-coupler, which must be energized to enable operation of the amplifier. If the Enable input is kept high before turning on the amplifier, the amplifier power output will be active immediately upon power on.

4.8 Status Indications

The following table lists the Flute amplifier status indications.

	Function	Latch Option	AOK	SO1	SO2	SO3
1	Amplifier OK (AOK)	N/A	Low	Open collector	Open collector	Open collector
2	External disable	No	Low	Low	Open collector	Low
3	Current limit	No	Low	Open collector	Open collector	Low
4	Short	Yes	Open collector	Low	Open collector	Low
5	Over temperature	Yes	Open collector	Open collector	Low	Low
6	Internal supplies protection	No	Open collector	Low	Low	Open collector
7	Under voltage	No	Open collector	Low	Open collector	Open collector
8	Over voltage	No	Open collector	Open collector	Low	Open collector
9	Shunt*	No	Low	Open collector	Low	Open collector
10	Power Up Reset	No	Open collector	Open collector	Open collector	Open collector

* This indication can be used as a digital input for activating an external shunt regulator.

Table 4-3: Flute Status Indications



Notes:

- **Without latch mode:**
The status indications are reset when the fault disappears.
- **With latch mode:**
The Short and Over Temperature Failure status indications are reset when the enable signal is temporarily removed from the enable input.
- **Multiple faults:**
Only the reading of the first fault is reliable. Additional faults add on to the status outputs and the indication is therefore meaningless.

Appendix: Technical Specifications

A.1 Power Ratings

Feature	Units	5/60	10/60	15/60	25/60	3/100	10/100	15/100	20/100	2/200	6/200	10/200	15/200
Minimum supply voltage	VDC	10				20				40			
Nominal supply voltage	VDC	50				85				170			
Maximum supply voltage	VDC	59				95				195			
Maximum continuous power output	W	240	480	720	1200	260	800	1200	1600	360	960	1600	2400
Efficiency at rated power (at nominal conditions)	%	> 97											
Maximum output voltage		Up to 100% of DC bus voltage											
Amplitude sinusoidal/DC continuous current	A	5	10	15	25	3.3	10	15	20	2.2 5	6	10	15
Peak current limit	A	2 x I _c											
Mounting method		PCB mounted											

A.2 Electrical Specifications

Feature	Details
Switching frequency on the load	32 kHz (±5%)
Current loop bandwidth	Up to 4 kHz
Current step response	< 150 μsec
Peak current duration (full rated peak current)	2.7 sec ±15%
Continuous current limit tolerance	-1% +5%
Peak current limit tolerance	-1% +5%
Current gain linearity	Better than ±1% of rated continuous current

Feature	Details
Current gain accuracy	Better than $\pm 5\%$ for $0.05 I_c < I_{motor} > I_p$
Current monitor accuracy	Better than $\pm 5\%$ for $0.05 I_c < I_{motor} > I_p$

A.3 Mechanical Specifications

Feature	Details
Size	82 x 62 x 25.4 mm (3.228 x 2.440 x 1.000 in)
Weight	250 g (8.8 oz)
Power pin material	Brass with tin plating
Power pin size	1.14 mm (0.45 in) square
Power pin PCB layout	1.8 ± 0.05 mm (0.071 ± 0.002 in)
Signal pin (J1, J2) material	Phosphor bronze with 10μ gold plating
Signal pin (J1, J2) size	0.5 ± 0.1 mm (0.02 ± 0.004 in) square
Signal pin (J1, J2) PCB layout	1 ± 0.05 mm (0.04 ± 0.002 in)

A.4 Environmental Conditions

Feature	Details
Ambient operating temperature	0 °C – 50 °C (32 °F – 122 °F)
Maximum case temperature	87 °C (188 °F)
Storage temperature	-40 ~ 100° C (-40 ~ 212° F)
Operating humidity	90% non-condensing
Maximum operating altitude	Up to 10,000 (30,000)
Storage humidity	98% non-condensing
Protective coating	Applied to all circuits