

# **ISP SERIES OPERATING MANUAL**

Rev 6/95

**ELMO-WARRANTY PERFORMANCE**

The warranty performance covers only ELMO's products and only the elimination of problems that are due to manufacturing defects resulting in impaired function, deficient workmanship or defective material. Specifically excluded from warranty is the elimination of problems which are caused by abuse, damage, neglect, overloading, wrong operation, unauthorized manipulations etc.

The following maximum warranty period applies:

<b>12 months from the time of operational startup but not later than 18 months from shipment by the manufacturing plant.</b>
--

Units repaired under warranty have to be treated as an entity. A breakdown of the repair procedure (for instance of the repair of a unit into repair of cards) is not permissible.

Damage claims, including consequential damages, which exceed the warranty obligation will be rejected in all cases.

If any term or condition in this warranty performance shall be at variance or inconsistent with any provision or condition (whether special or general) contained or referred to in the Terms and Conditions of Sales set out at the back of Elmo's Standard Acknowledge Form, than the later shall prevail and be effective.

## How to use this manual - Flow Chart

The ISP amplifier is designed for OEM applications. It enables the user to adjust the amplifier for various types of motors and to save valuable adjusting time in repetitive applications.

Use the following flow chart in order to determine the chapters that you should read. If you are a new user of the ISP, you should read chapters 1-4 which will familiarize you with the product.

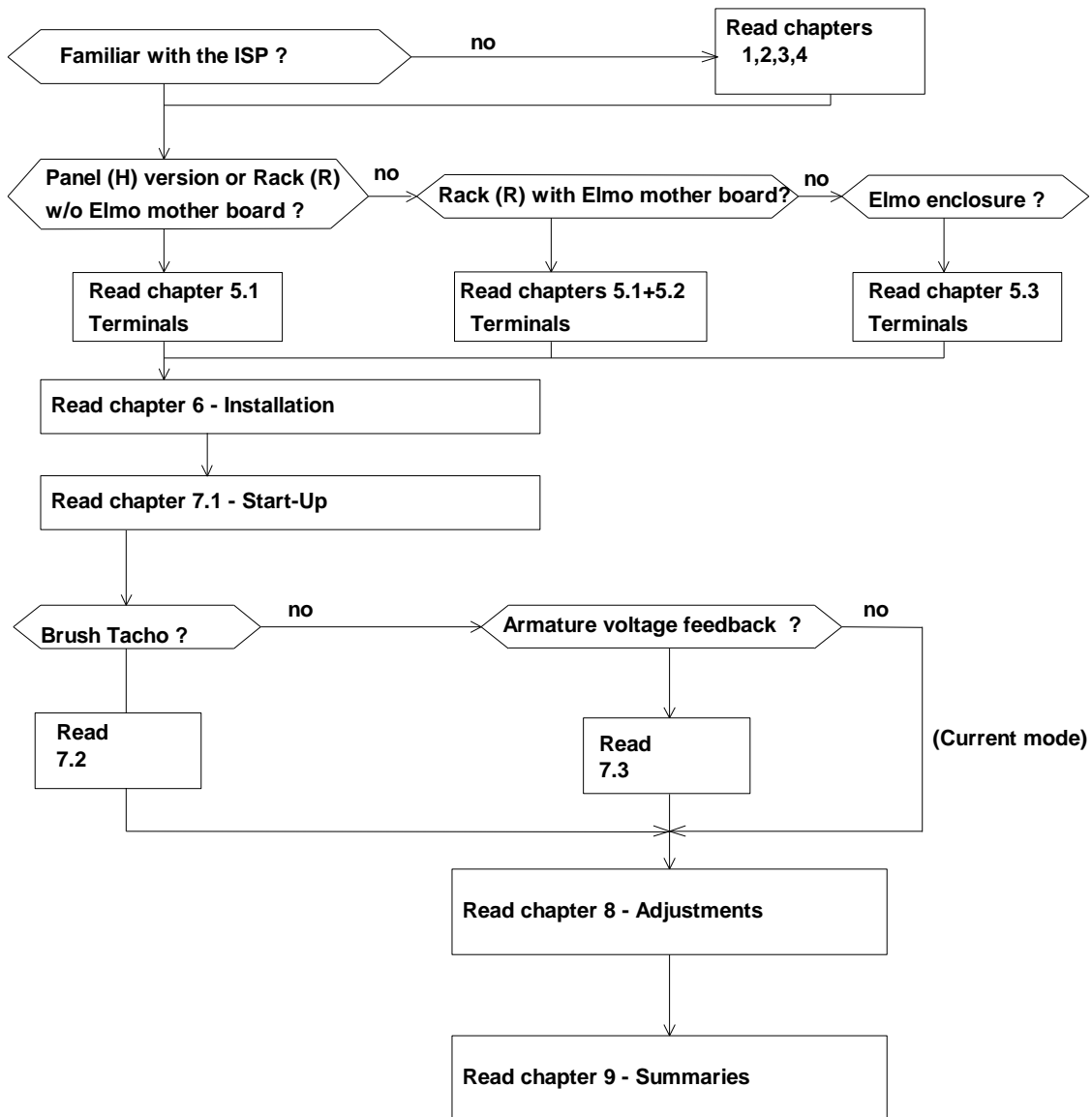

## TABLE OF CONTENTS

1. Description .....	6
2. Type Designation .....	7
3. Technical specifications .....	7
4. Operation of the servo control .....	8
4.1 Inputs.....	8
4.2 Velocity mode.....	9
4.2.1 Velocity control using armature voltage feedback .....	10
4.3 Current mode.....	10
4.4 Current loop.....	11
4.5 Current limits.....	11
4.5.1 Time dependent peak current limit .....	11
4.5.2 Dynamic contouring of continuous and peak current limits	12
4.6 Operation of the shunt regulator.....	13
4.7 Protective functions.....	14
4.7.1 Short circuit protection.....	14
4.7.2 Under/over voltage protection.....	14
4.7.3 Temperature protection.....	14
4.7.4 Insufficient load inductance.....	14
4.7.5 Loss of velocity feedback signal .....	14
4.7.6 Shunt regulator duty cycle.....	14
5. Terminal Description .....	17
5.1 Terminals for Horizontal and Rack mounting versions .....	17
5.2 Mother Board terminals.....	20
5.3 Terminals for ISP mounted in 3U size ENC.....	22
6. Installation procedures .....	26
6.1 Mounting.....	26
6.2 Wiring.....	26
6.3 Load inductance.....	27
6.4 AC power supply.....	27
6.5 Wiring diagrams.....	28
7. Start - Up Procedures .....	33
7.1 Common procedures for all amplifiers types .....	33
7.1.1 Inhibit and CW/CCW logic .....	33
7.1.2 Velocity mode.....	36
7.1.3 Current mode.....	36

7.1.4	Activating the loss of tacho protection (velocity mode only)	37
7.1.5	Latch mode of the protective functions	38
7.1.6	Activating the dynamic contouring of the current limits	38
7.2	Velocity control using tachogenerator feedback	38
7.3	Velocity control using armature voltage feedback	39
8.	Amplifier adjustment and diagnostics	40
8.1	Balance adjustment	40
8.2	Current limit adjustment	40
8.3	Adjusting the motor speed (velocity mode only)	41
8.4	Adjustment of the IxR compensation	41
8.5	Response adjustment (velocity mode only)	42
9.	Tables and Summaries	44
9.1	Adjusting trimmers	44
9.2	LED diagnostics	44
Appendix A	- Response adjustment - current loop	45
Appendix B	- Current limits contour adjustment	47
List of ELMO	Service Centers	77

## **1. Description**

The ISP is an amplifier/power supply package, assembled on a single heatsink with a Eurocard size. The rated output is up to 1500W.

The integrated power supply includes a shunt regulator.

The ISP is available in either panel version or rack version with a 32 poles DIN 41612 connector.

### **Standard features**

- \* Zero deadband.
- \* Excellent linearity.
- \* 2 inputs.
- \* Differential input.
- \* Motor current monitor.
- \* Inhibit/fault indication (free contact relay).
- \* Remote control functions: Inhibit and CW/CCW disable.
- \* Adjustable compensation.
- \* Adjustable continuous and peak current limits.
- \* Dynamic contouring of continuous and peak current limits.
- \* Input balance (offset) adjustment.
- \* Operation in two velocity modes (Tacho or armature voltage feedback) or current mode.
- \* LEDs diagnostics.
- \* Option - Personality board for ease of replacement: the board includes all the adjusting trimmers.

### **Protective functions:**

The following protections cause an inhibit which is either self-restart or latched (for manual reset) selectable by the user:

- \* Under / over voltage.
- \* Short circuit: between outputs or each output to ground.
- \* Low inductance.
- \* RMS current limit.
- \* Loss of tacho feedback.
- \* Over temperature.
- \* Duty cycle limit of the power supply's shunt regulator.

## 2. Type Designation

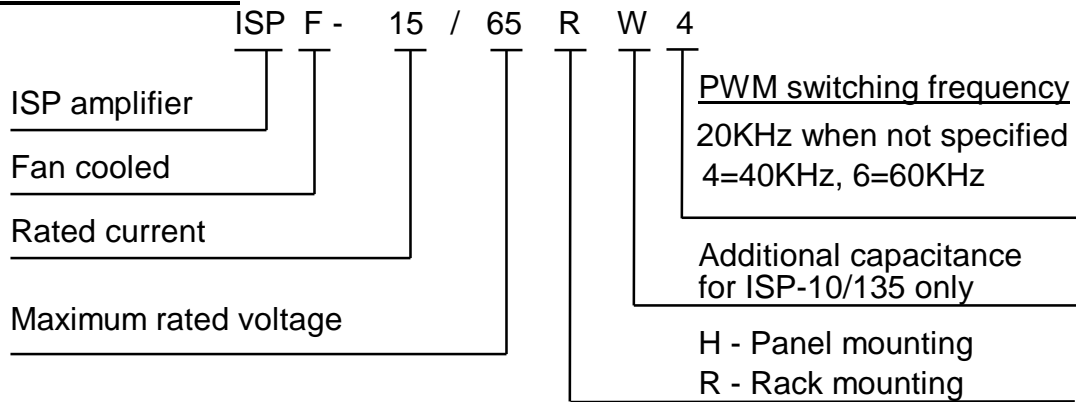

## 3. Technical specifications

Type	AC Supply *	Current limits	Size Panel types	Size Rack	Weight
ISP-8/65	14-65	8/16	SP1	3U/8T	0.7
ISP-15/65	14-65	15/30	SP1	3U/8T	0.7
ISP-5/135	80-135	5/10	SP1	3U/8T	0.7
ISPF-10/135_W	28-135	10/20	SP3	3U/12T	0.8
ISP-10/135_W	28-135	10/20	SP4	3U/19T	1.6

- \* DC output voltage is 130% of AC input voltage.
- \* 20KHz, 40KHz or 60KHz switching frequency.
- \* 2KHz current loop response (minimum)
- \* Outputs voltages of +5V/100mA, +15V/50mA each, for external use.
- \* Efficiency at rated current - 97%.
- \* Drift: 10mV/°C (referred to input)
- \* Operating temperature: 0-50 °C.
- \* Storage temperature: -10 - +70 °C.
- \* The W version includes additional 3000 μF in the bus filter.

---

\* These are the absolute minimum-maximum AC supply voltages under any condition.

## 4. Operation of the servo control

### 4.1 Inputs

The ISP has 3 inputs: 2 single ended inputs (no.1 at terminal 1 and no.2 at terminal 5) and one differential input at terminals 3,4.

The current gain of inputs 1 and 2 (current mode) is given by:

$$G_c = \frac{8 \times I_c \times K_i}{15 + R_i} \quad (\text{A/V})$$

$I_c$  - amplifier rated continuous current.

$R_i$  - input resistor in Kohm.

$R_1$  for input 1

$R_2$  for input 2

$K_i$  - position of wiper of trimming potentiometer

$K_i=0.33$  when trimmer is fully CW.

$K_i=1$  when trimmer is fully CCW.

The current gain of the differential input for  $R_3=R_4$  (current mode) is given by:

$$G_{cd} = \frac{5.33 \times I_c}{R_3} \quad (\text{A/V})$$

$R_3$  in Kohm

The current gain of the single ended inputs in velocity mode is given by (place the appropriate  $G_c$  for each input):

$$G_v = \frac{400 \times I_c \times K_i}{(15+R_i) \times R_6} \quad (\text{A/V})$$

$R_i, R_6$  in Kohm

The current gain of the differential input in velocity mode is given by:

$$G_{vd} = \frac{266 \times I_c}{R_3 \times R_6} \quad (\text{A/V})$$

R3,R6 in Kohm

The maximum input voltage at terminals 1 or 5 is calculated by:

$$V_{in_{max}} = 10 + 0.6R_i \quad (\text{Volts})$$

Ri in Kohm

The maximum input voltage at terminals 3,4 is calculated by:

$$V_{d_{max}} = 10 + R_3 \quad (\text{Volts}),$$

R3=R4 in Kohm

## 4.2 Velocity mode

In this mode op amp U1/A is employed as a high gain error amplifier. The amplifier sums velocity command and the tachogenerator feedback signal, and provides the necessary servo compensation and gain adjustments, resulting in stable, optimum servo operation.

This op amp is configured with two feedback paths:

One, in the form of a resistive T network, controls the DC gain of this amplifier. The equivalent value of a T network is given by:

$$R_f = \frac{10^{10}}{R_6}$$

Resistor R6 is mounted in solderless terminals so it can be changed easily whenever the DC gain of the error amplifier is to be changed. The AC gain is controlled by C1, R5 and COMP trimmer. Maximum AC gain is obtained with COMP trimmer set fully CW. Setting COMP trimmer fully CCW removes AC gain and no lag in response occurs. R5 and C1 are mounted in solderless terminals and can be

easily replaced in cases when COMP trimmer range is not enough to get optimum result.

The output of the error amplifier is:

$$V_o = (V_1 G_{V1} + V_2 G_{V2}) \times \left[ \frac{1 + Sx C1 x R5}{1 + Sx C1 x R5 (1 + Rfx Ki / R5)} \right]$$

$V_1, V_2$ , - Input signals

$G_{V1}, G_{V2}$  - Gain of inputs.

$K_i$  = Position factor of the wiper of COMP trimmer.

Full CW = 0.1

Full CCW = 1

The feedback element must be connected for negative feedback.

The polarity of the ISP servo amplifiers is such that a positive input signal results in a negative voltage at terminal M1 with respect to terminal M2.

#### 4.2.1 Velocity control using armature voltage feedback

By inserting R8 to its solderless terminals, the armature voltage is fed into the error amplifier to be used as a velocity feedback. This feature is useful for all cases when low regulation ratio and low speed accuracy are acceptable.

### 4.3 Current mode

In order to operate the servo amplifier as a current amplifier, the velocity loop should be disabled. This is done by converting the error amplifier into a low gain DC amplifier which has a flat response beyond the desired current bandwidth. In this mode, R6 and C1 have to be removed from the circuit.

#### 4.4 Current loop

Current loop control is obtained by op amp U1/B (Current amplifier) and R7, C2 which form a lag-lead network for current loop. The standard amp is equipped with R7 (100Kohm) and C2 (0.01 $\mu$ F) to get optimum current response for an average motor in this power range. These components are mounted in solderless terminals.

#### 4.5 Current limits

The servo amplifier can operate in the following voltage-current plane:

		+V	
-Ip	-Ic	Ic	Ip
Intermittent zone	Continuous zone	-V	

Ic - Continuous current      Ip - Peak current

Fig. 4.1: Voltage-Current plane

Each amplifier is factory calibrated to have this shape of voltage-current operating area with rated values of continuous and peak current limits. In addition the peak current limit is time dependent as explained in 4.5.1.

##### 4.5.1 Time dependent peak current limit

The peak current is so designed that its duration is a function of the peak amplitude and the motor actual operating current before the peak demand. The maximum peak current is available for 1.6 second. The duration of Ip is given by:

$$T_p = 2.2 \ln \frac{I_p - I_{op}}{I_p - I_c}$$

$I_c$  - Amplifier continuous current rating.

$I_p$  - Peak demanded (not amplifier  $I_p$ )

$I_{op}$  - Actual operating current before the peak demand.

Example:

A motor is driven by an ISP-15/65 amplifier at constant speed and constant current of 5A. What is the maximum possible duration of a 20A peak ?

$$T_p = 2.2 \ln \frac{20 - 5}{20 - 15} = 2.42 \text{ seconds}$$

#### 4.5.2 Dynamic contouring of continuous and peak current limits

Most of the servo motors have reduced continuous current limits at high speeds (Fig. 4.2). This phenomenon is due to commutation limits and iron losses which become significantly high as speed increases and this leads to reduction of the continuous current limit. The ISP amplifiers have the features which enable the user to define the current limit envelope as closely as possible to the motor operating envelope defined by the motor manufacturer.

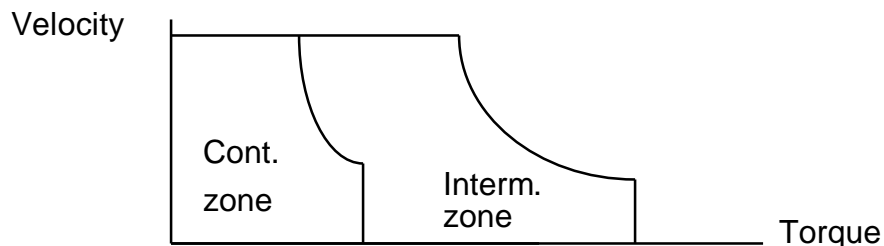

Fig. 4.2:

Typical operating envelope of a brush servo motor

#### 4.6 Operation of the shunt regulator

A shunt regulator is included in the power supply section of the ISP. The shunt regulator is a switching type, wherein dissipative elements (resistors) are switched across the DC bus, whenever the voltage reaches a predetermined level. The function of the shunt regulator is to regulate the voltage of the DC bus during the period of motor deceleration, when there is a net energy outflow from the motor to the amplifier. The amplifier handles this reverse energy just as efficiently as it provides energy to the motor, hence, most of the energy is passed through the amplifier to the power supply, where the returning energy charges the filter capacitors above their normal voltage level, as determined by the AC incoming voltage.

When the capacitors charge-up reaches the predetermined voltage level ( $V_r$ ), the shunt regulator begins its regulating action. The bus is regulated to this range until regeneration ceases.

On multi-axis systems, it is recommended to parallel the DC bus of all the ISPs.

##### SHUNT specifications

Type	Reg. Voltage ( $V_r$ )	Reg. Current (A)
ISP-8/65	91	11
ISP-15/65	91	22
ISP-5/135	191	6
ISPF-10/135_W	191	12
ISP-10/135_W	191	12

## **4.7 Protective functions**

All the protective functions (excluding 4.7.6) activate internal inhibit. There are two modes of resetting the amplifier after the cause of the inhibit disappears: Self Restart and Latch.

- Self restart: The amplifier is inhibited only for the period that the inhibit cause is present.
- Latch: All failures latch the inhibit and only a reset signal will clear the latch.

### **4.7.1 Short circuit protection**

This protection is realized by sensing current in the DC line. Every current peak above a certain value will inhibit the amplifier for a period of approx. 30mS (if in restart mode).

The amplifier is protected against shorts between outputs and either output to ground.

### **4.7.2 Under/over voltage protection**

Whenever the DC bus voltage is under or over the limits indicated in the technical specifications, the amplifiers will be inhibited.

### **4.7.3 Temperature protection**

Temperature sensor is mounted on the heatsink. If, for any reason, the temperature exceeds 85°C the amplifier will be inhibited. The amplifier will restart when the temperature drops below 80°C.

### **4.7.4 Insufficient load inductance**

Whenever the load inductance is too small, the current spikes will be very high. In such cases the amplifier will be disabled.

### **4.7.5 Loss of velocity feedback signal**

If the amplifier loses the velocity feedback signal it will inhibit itself. In the "Self Restart" mode it will restart after a delay of 6-8 seconds.

### **4.7.6 Shunt regulator duty cycle**

Whenever the ratio between "ON" time to "OFF" time of the shunt exceeds 5-10% the shunt will be inhibited.

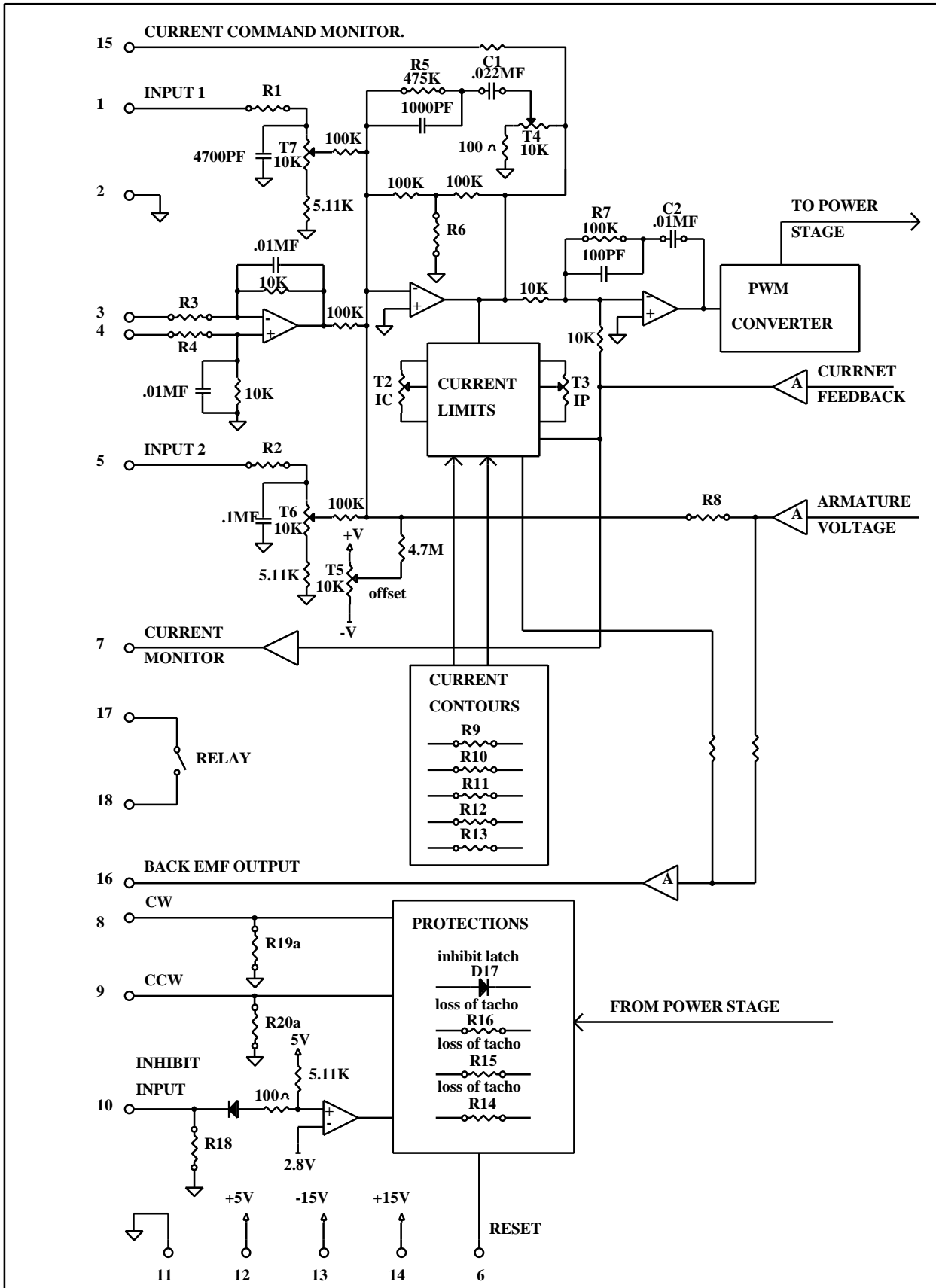

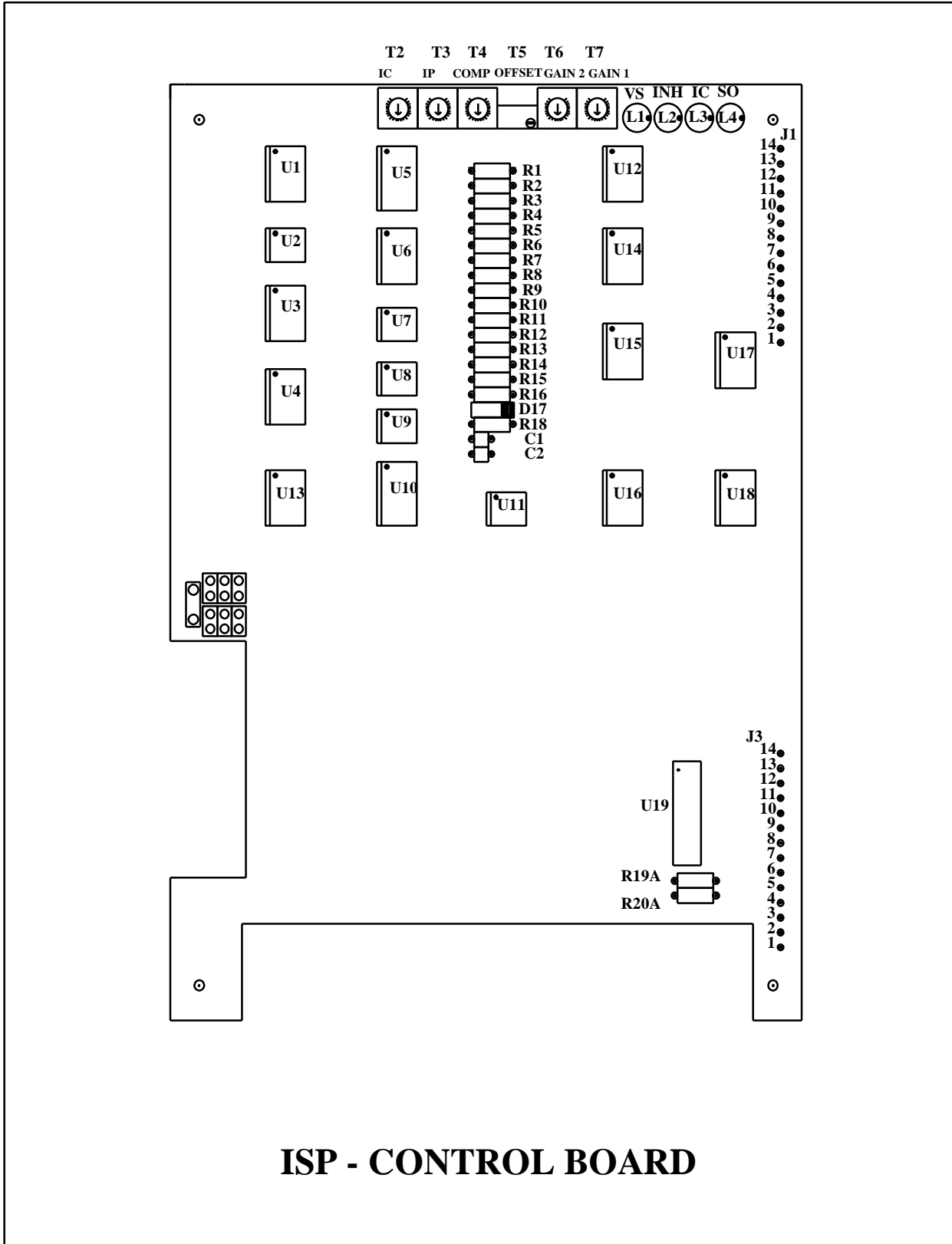

## 5. Terminal Description

### 5.1 Terminals for Horizontal and Rack mounting versions

Power stage

H	R	Function	Remark
AC	2ac,4c	AC input	All pins are shorted on the PCB.
M1	8ac,10a	Armature output	This output will be negative when a positive signal is fed to one of the inputs. All pins are shorted on the PCB.
M2	6ac,4a	Armature output	This output will be positive when a positive signal is fed to one of the inputs. All pins are shorted on the PCB.
AC	12ac,10c	AC input	All pins are shorted on the PCB.

Control stage

H	R	Function	Remark
1	32a	Input 1	For more details see 4.1.
2	32c	Circuit common	
3	30a	Negative differential input	For more details see 4.1.
4	30c	Positive differential input	For more details see 4.1.
5	28a	Input 2	For more details see 4.1.
6	28c	Reset for latch mode	low level input voltage * enables the amplifier (see 7.1.5).
7	26a	Current monitor	Ic Scale is = ----- (A/V) 3.75
8	26c	CW disable	Two modes - see chapter 7.1.1 *

---

\*  $-1V < V_{il} < 1V$  ;  $2V < V_{ih} < 30V$

Source sink capability - 2mA.

## Control stage - Cont.

H	R	Function	Remark
9	24a	CCW disable	Two modes - see chapter 7.1.1 *
10	24c	Inhibit input	Two modes - see chapter 7.1.1 *
11	22a	Circuit common	
12	22c	+5V	100mA
13	20a	-15V	+ 5%, 50mA external load.
14	20c	+15V	+ 5%, 50mA external load.
15	18a	Current command monitor	Ic Scale is = ----- (A/V) 3.75
16	18c	Back EMF output	See Appendix B.
17, 18	16a, 16c	Inhibit output	A potential free relay contact. Closed when amplifier is enabled. Contact rating: 0.5A, 200V, 10W
19	14a	DC power voltage output - common	5A max.
20	14c	DC power voltage output - positive	5A max.

Remark: In the following paragraphs the terminals will be related to all the mounting types as in the the following example:

H-18,R-16c,E-J1/8.

\*  $-1V < V_{il} < 1V$  ;  $2V < V_{ih} < 30V$

Source sink capability - 2mA.

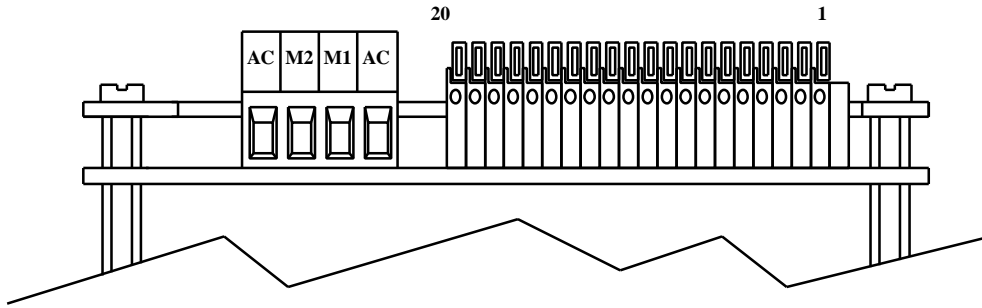

**TERMINALS OF ISP - PANEL VERSION**

## 5.2 Mother Board terminals

The MBA-ISP/N is designed for 19" rack systems. It has screw type terminals for both power and signals with identical designations as in the panel versions except for the following new terminals:

21	Potential free Inhibit Input (+). See 7.1.1.
22	Potential free Inhibit Input (-). See 7.1.1.

The Potential Free Inhibit Input is applicable only when the "inverted inhibit logic" is used (R18 in the amplifier is inserted). An opto-Coupler (IL5) is used to isolate between the Inhibit signal and the amplifier circuit. Activating this opto-coupler is done by inserting R1 on the mother board according to the following relation:

$$R1 = 100 \times V_{inh} \text{ (ohm)}$$

$V_{inh}$  - voltage in the inhibit input.

Standard value is 2.4K (For 24 volts) Source must be capable of source or sink 10mA.

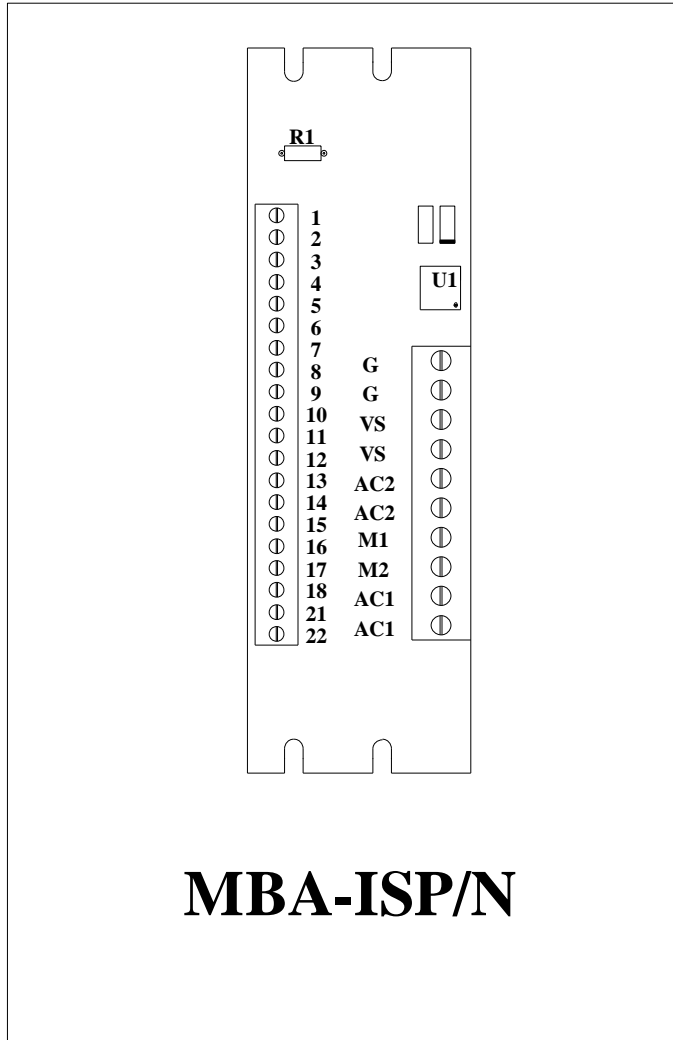

# MBA-ISP/N

### 5.3 Terminals for ISP mounted in 3U size ENC.

The MBA-ISP/3UE is designed for Elmo enclosures. It has screw type terminals for the power and D-type connectors for the signals.

The Potential Free Inhibit Input is applicable only when the "inverted inhibit logic" is used (R18 in the amplifier is inserted). An opto-Coupler (IL5) is used to isolate between the Inhibit signal and the amplifier circuit. Activating this opto-coupler is done by inserting R1 on the mother board according to the following relation:

$$R1 = 100 \times V_{inh} \text{ (ohm)}$$

$V_{inh}$  - voltage in the inhibit input.

Standard value is 2.4K (For 24 volts) Source must be capable of source or sink 10mA.

#### Power Terminals

Terminal	Function	Remark
AC	AC input	
M1	Armature output	This output will be negative when a positive signal is fed to one of the inputs.
M2	Armature output	This output will be positive when a positive signal is fed to one of the inputs.
AC	AC input	
GND	Ground	

## Control connector - J1

Pin	Function	Remark
1	Input 2	For more details see 4.1.
2	Back EMF output	See Appendix B.
3	Input 1	For more details see 4.1.
4	Negative differential input	For more details see 4.1.
5	Positive differential input	For more details see 4.1.
6	Current monitor	$I_c$ Scale is = ----- (A/V) 3.75
7	Current command monitor	$I_c$ Scale is = ----- (A/V) 3.75
8,15	Inhibit output	A potential free relay contact. Closed when amplifier is enabled. Contact rating: 0.5A, 200V, 10W
9,10	Circuit common	
11	+15V	+ 5%, 50mA external load.
12	-15V	+ 5%, 50mA external load.
13	+5V	100mA
14	Circuit common	

## Control connector - J2

Pin	Function	Remark
1	Inhibit input	Potential free inhibit input (-). See 7.1.1 *
2	Inhibit input	Potential free inhibit input (+). See 7.1.1 *
3	Inhibit input	Two modes - see chapter 7.1.1 *
4	CCW disable	Two modes - see chapter 7.1.1 *
5	CW disable	Two modes - see chapter 7.1.1 *
6	Reset for latch mode	low level input voltage * enables the amplifier (see 7.1.5).
7	Back EMF output	See Appendix B.
8	Input 2	For more details see 4.1.
9	-15V	+ 5%, 50mA external load.
10	+15V	+ 5%, 50mA external load.
11,12	Circuit common	
13	+5V	100mA
14,15	Circuit common	

Remark: In the following paragraphs the terminals will be related to all the mounting types as in the the following example:

H-18,R-16c,E-J1/8.

---

\*  $-1V < V_{il} < 1V$  ;  $2V < V_{ih} < 30V$

Source sink capability - 2mA.

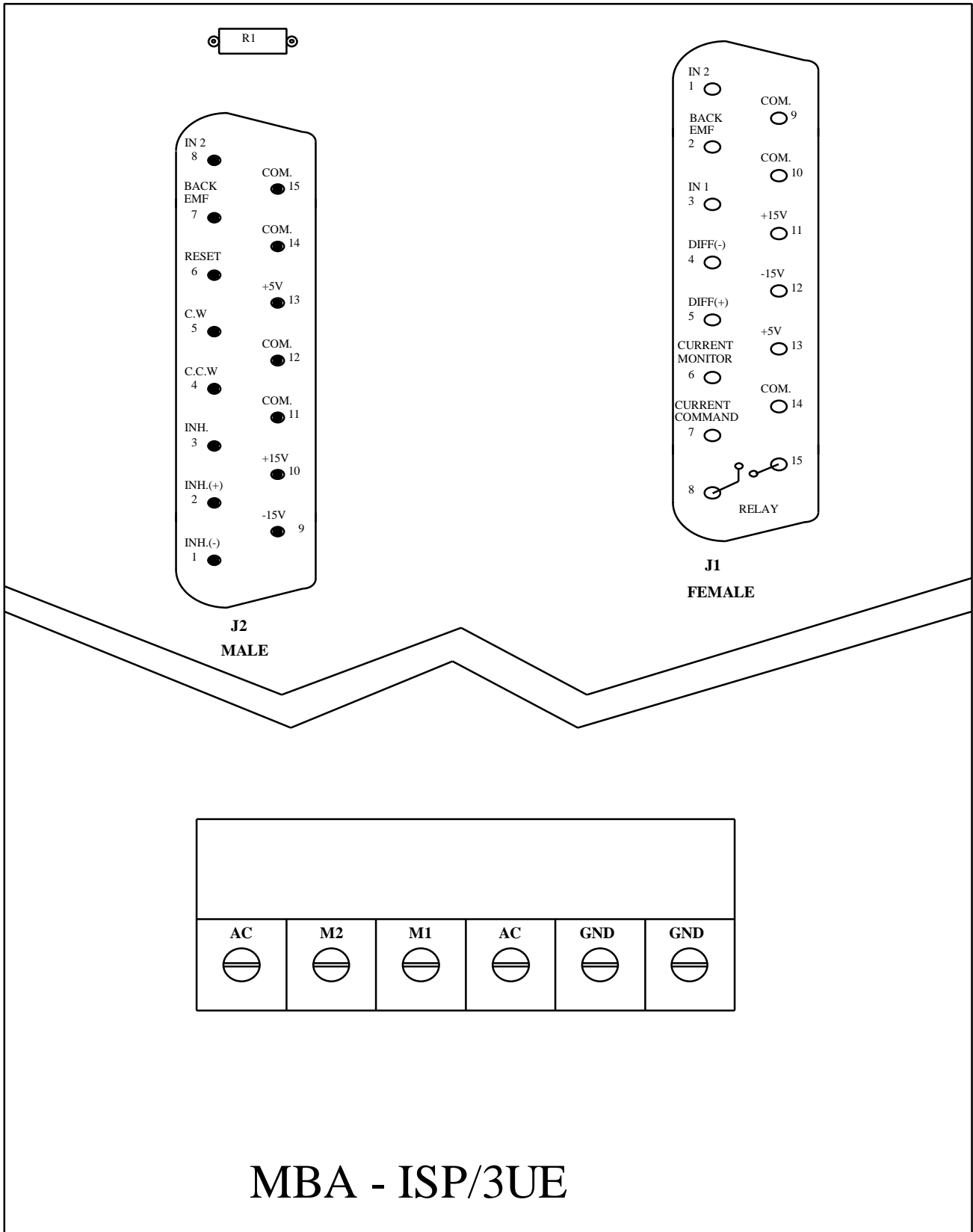

# MBA - ISP/3UE

## **6. Installation procedures**

### **6.1 Mounting**

The ISP series dissipates its heat by natural convection. For optimum dissipation the amplifier should be mounted with the fins vertical.

### **6.2 Wiring**

Proper wiring, grounding and shielding techniques are important in obtaining proper servo operation and performance. Incorrect wiring, grounding or shielding can cause erratic servo performance or even a complete lack of operation.

- a) Keep motor wires as far as possible from the signal level wiring (feedback signals, control signals, etc.).
- b) If additional inductors (chokes) are required, keep the wires between the amplifier and the chokes as short as possible.
- c) Minimize lead lengths as much as is practical.
- d) Use twisted and shielded wires for connecting all signals (command and feedback). Avoid running these wires in close proximity to power leads or other sources of EMI noise.
- e) Use a 4 wires twisted and shielded cable for the motor connection.
- f) Shield must be connected at one end only to avoid ground loops.
- g) All grounded components should be tied together at a single point (star connection). This point should then be tied with a single conductor to an earth ground point.
- h) After wiring is completed, carefully inspect all conditions to ensure tightness, good solder joints etc.

<p>A reliable connection with the spring type connectors is achieved with wires of 0.5mm<sup>2</sup> (AWG 20) stripped to a length of 11mm (.043").</p>
---

### 6.3 Load inductance

The total load inductance must be sufficient to keep the current ripple within the 50% limit (10-20% of rated current is recommended). The armature current ripple ( $I_r$ ) can be calculated by using the following equation:

$$I_r = \frac{0.5 \times V_s}{f \times L} \quad (\text{A})$$

$L$  - load inductance in mH.

$V_s$  - Voltage of the DC supply in Volts.

$f$  - Switching frequency in KHz.

If motor inductance does not exceed this value, a choke should be added (on the motor branch) summing together the required inductance

$$L_{ch} = L - L_{arm}$$

$L_{ch}$  - Choke inductance

$L_{arm}$  - Armature inductance

### 6.4 AC power supply

AC power supply can be at any voltage in the range defined within the technical specifications (chapter 3). However, if the power source to the power supply is the AC line (through a transformer), safety margins have to be considered to avoid activating the under/over voltage protection due to line variations and/or voltage drop under load.

The nominal DC bus voltage should be in the following range:

$$1.2V_{dcmin} < V_{dc} < 0.9V_{dcmax}$$

$V_{dcmin}$  - Minimum DC bus in the table of chapter 3

$V_{dcmax}$  - Maximum DC bus in the table of chapter 3

6.5 Wiring diagrams

# MOTOR WIRING

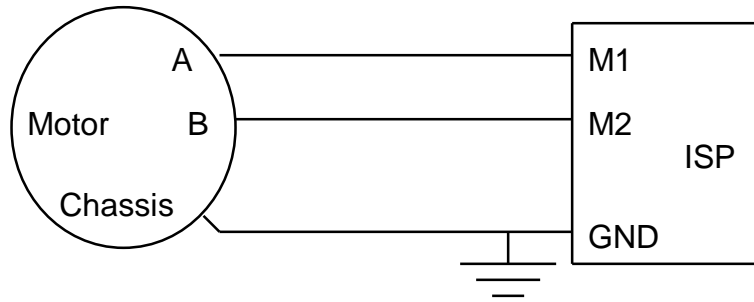

Minimum acceptance

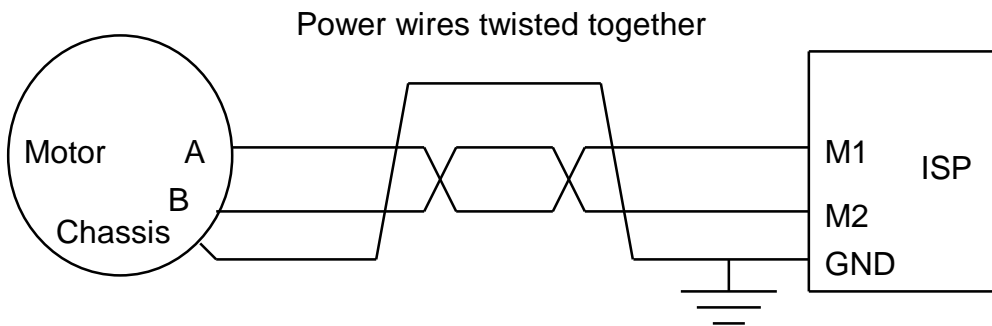
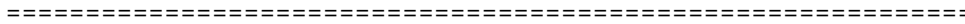

Acceptable for most applications

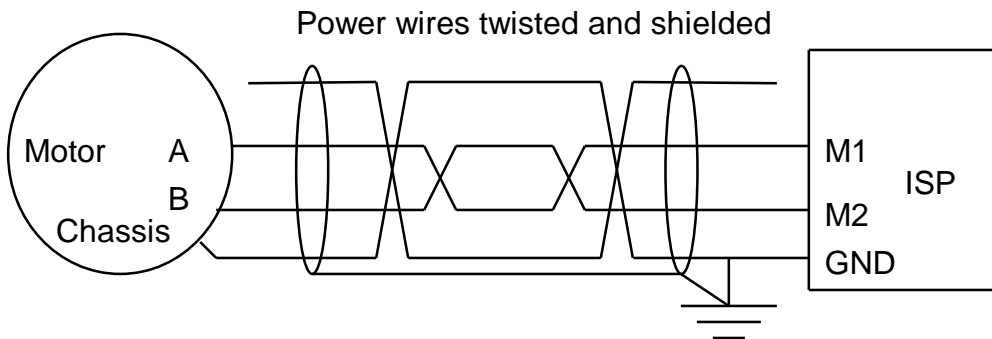
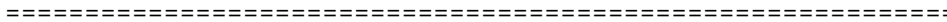

Optimum wiring, minimum RFI

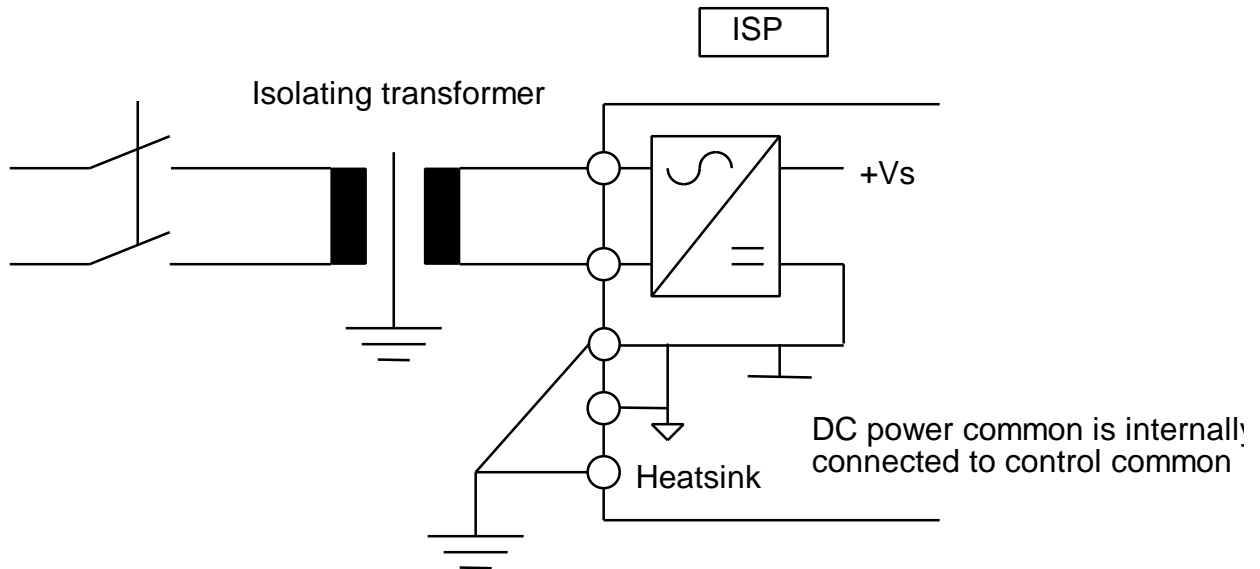

### Guide lines for connecting a non isolated amplifier with an isolating power transformer

#### Ground:

DC power common

Motor chassis

Amplifier's heat sink

#### Do not ground:

Control common - It is internally connected to the power common. Grounding the control common will create a ground loop.

#### Caution:

- If source of motor command is grounded, use amplifier's differential input. Otherwise, ground loop is created.

## SINGLE PHASE TRANSFORMER

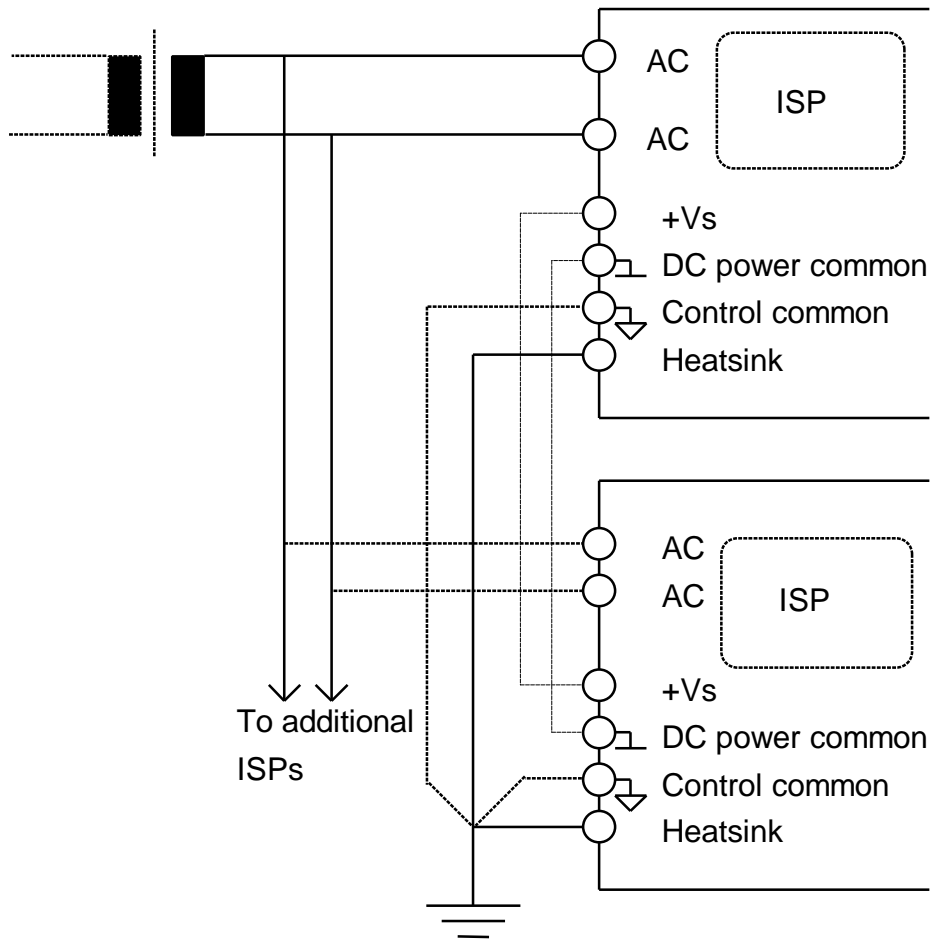
CONNECTING MORE THAN ONE ISP

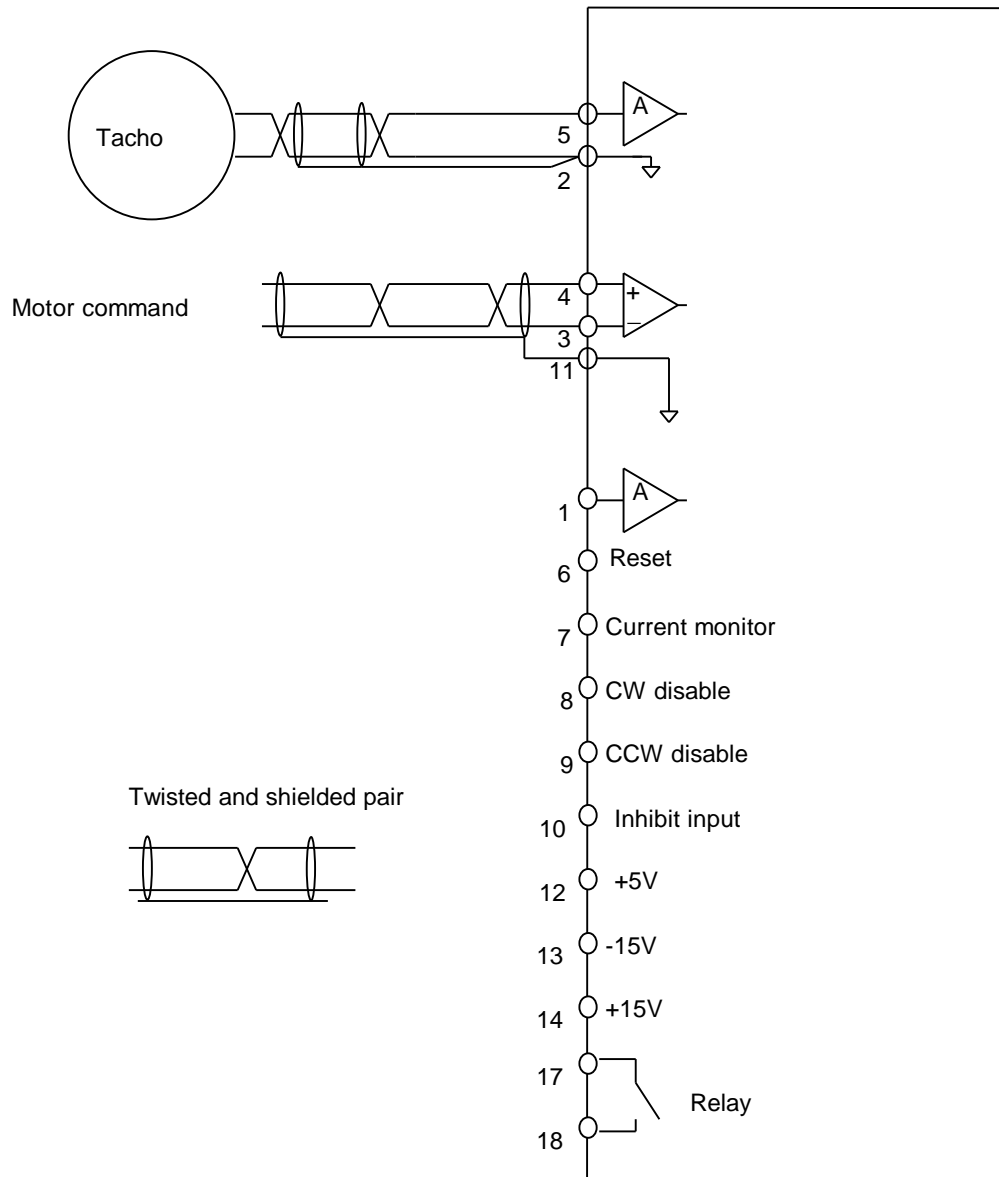

## ISP CONTROL CONNECTIONS

## TACHOGENERATOR FEEDBACK

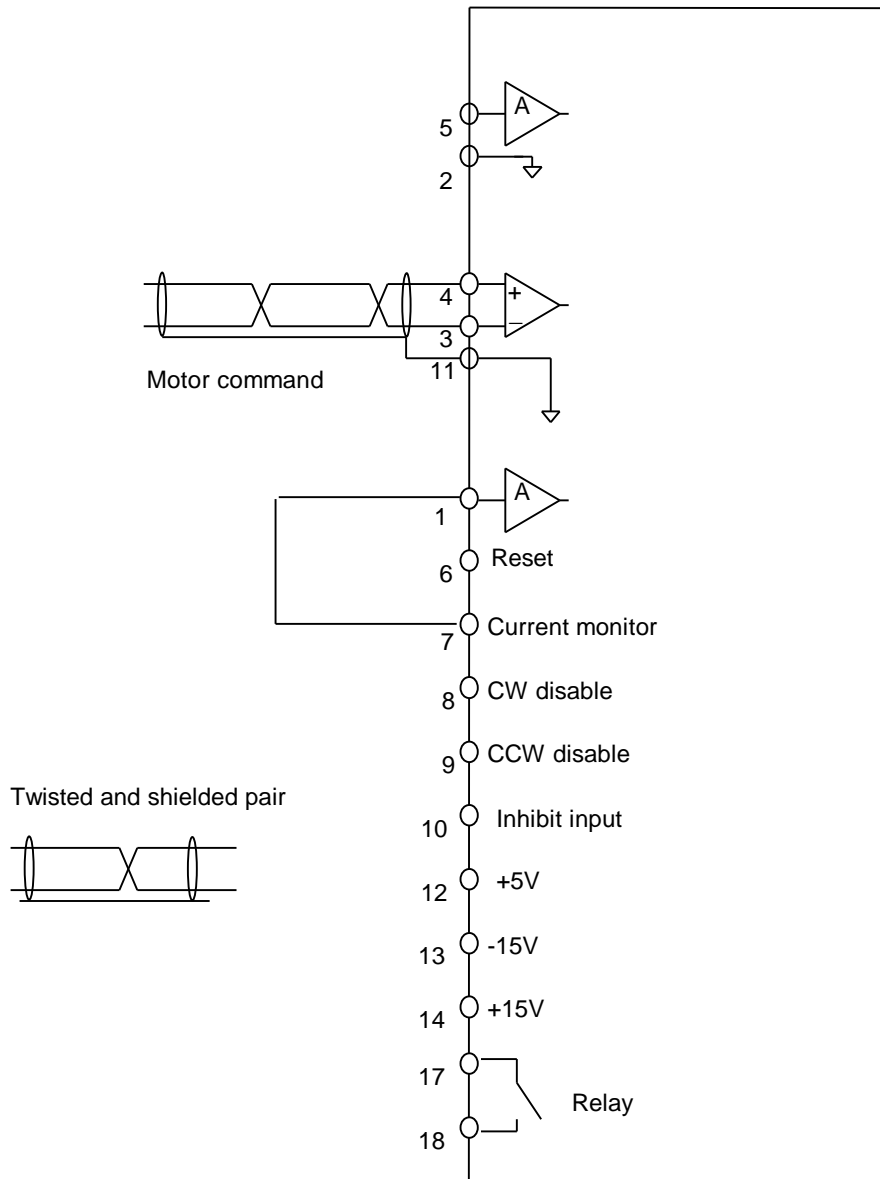

## ISP CONTROL CONNECTIONS

### ARMATURE VOLTAGE FEEDBACK

## 7. Start - Up Procedures

All the operations of this chapter do not require power on the unit. The steps of paragraph 7.1 must be performed before proceeding to the appropriate feedback sensor section.

### 7.1 Common procedures for all amplifiers types

#### 7.1.1 Inhibit and CW/CCW logic

Select the desired Inhibit and CW/CCW logic you need:

##### a) Disable by Low

Inhibit/CW/CCW functions will be activated by connecting their inputs to a low level signal. If no signal is applied to these inputs the amplifier will be enabled upon power on.

For this logic, R18 (for Inhibit), R19a (for CW), R20a (for CCW) should not be installed.

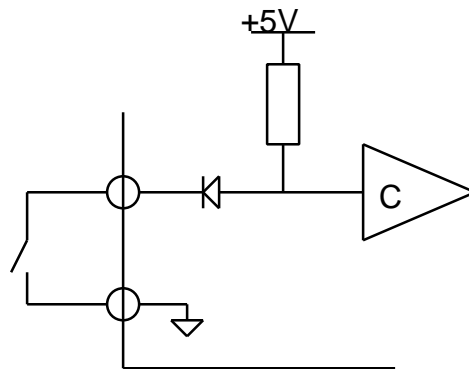

ISP DISABLED BY ACTIVE LOW OR CLOSED CONTACT

$$-1V \leq V_{il} < 1V$$

$$2V \leq V_{ih} < 30V$$

### b) Enable by High

Inhibit/CW/CCW functions will be de-activated by connecting their inputs to a high level signal. If no signal is applied to these inputs the amplifier will be disabled upon power on.

For this logic insert 3.6Kohm (+10%) resistors for R18 (Inhibit), R19a (CW), R20a (CCW). The power of these resistors is calculated according to:

$$P_{min} = V^2 / 1500 \text{ (Watt)}$$

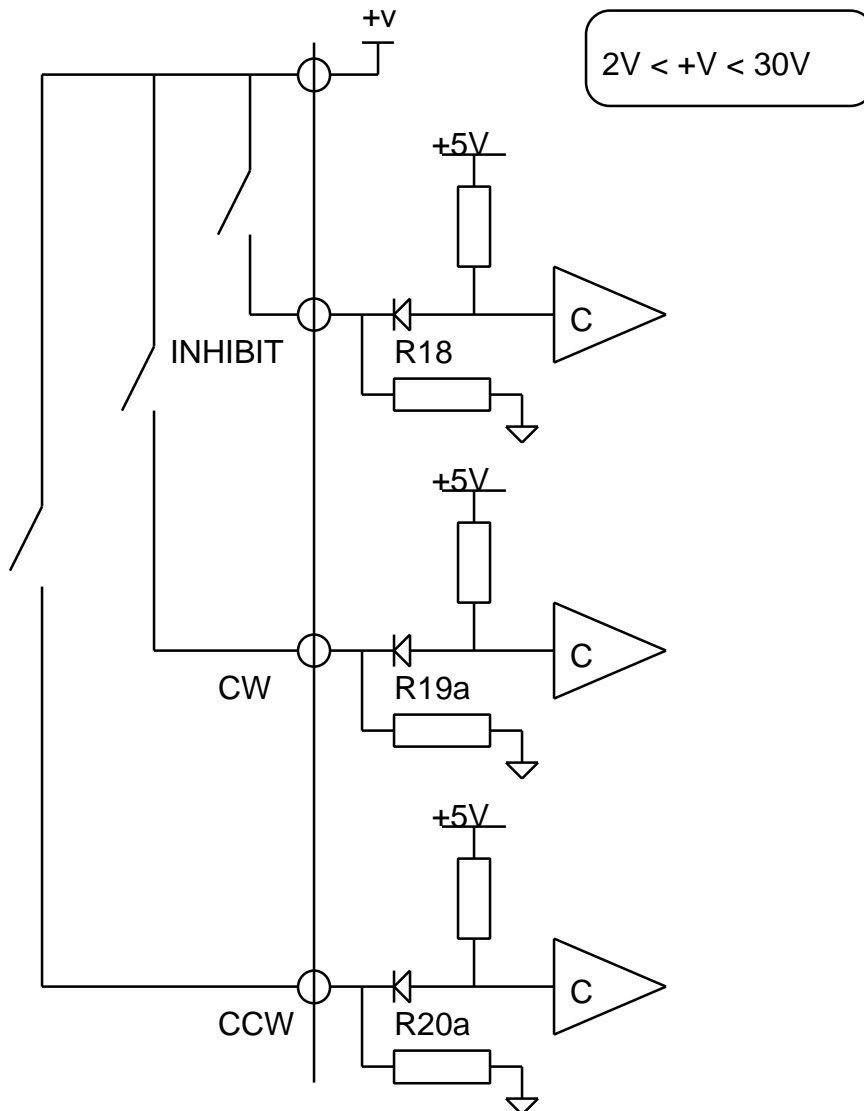

ISP ENABLED BY ACTIVE HIGH OR CLOSED CONTACT

## OPTO-ISOLATED INHIBIT

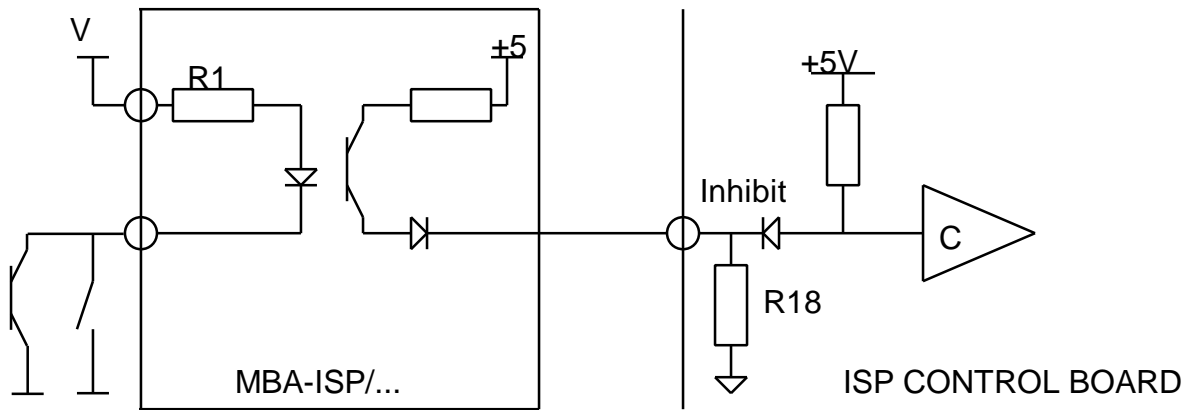

ISP ENABLED BY ACTIVE LOW OR CLOSED CONTACT

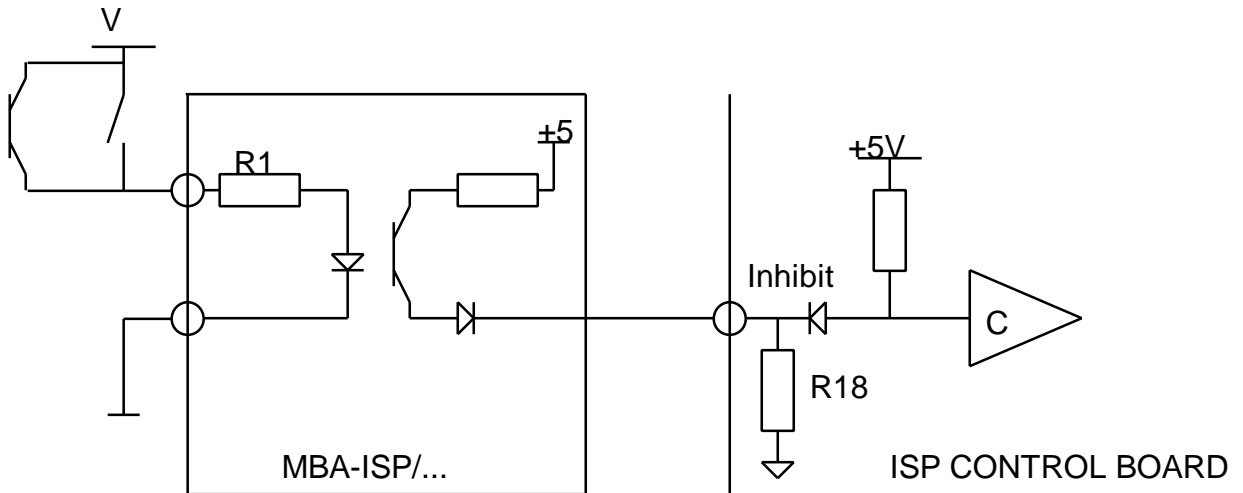

ISP ENABLED BY ACTIVE HIGH OR CLOSED CONTACT

$$R1 = 100 \times V \quad (\text{ohm})$$

V - Voltage at the inhibit input.

Standard value is 2.4K (for 24V). Source must be capable to source or sink 10mA.

### 7.1.2 Velocity mode

To operate in velocity mode the velocity loop should be enabled by converting the error amplifier to a high gain PI amplifier.

**Make sure that: R6 (30ohm), R5 (475Kohm) and C1 (0.022  $\mu$ F), in solderless terminals, are installed on the board.**

### 7.1.3 Current mode

#### a) Converting the amplifier into current mode

To operate in current mode the velocity loop should be disabled by converting the error amplifier to a low gain proportional amplifier.

- Remove R6 (in solderless terminals).
- Remove C1 (in solderless terminals).

In addition, you must make sure that the velocity feedback signal is not entering the error amplifier. If a tachogenerator is used, make sure that it is not connected to the amplifier.

#### b) Selecting the reference signal gain

The ISP has 2 single ended inputs (terminals H-1,R-32a,E-J1/3 and H-5,R-28a,E-J1/1) and a differential input (terminals H-3,R-30a,E-J1/4, and H-4,R-30c,E-J1/5).

**The standard procedure recommends to use the differential input for the reference signal.**

Following are the input maximum voltage and impedance with the standard values of input resistors:

INPUT - RESISTOR	STANDARD VALUE	MAX. VOLTAGE	Current Gain(A/V) (in current mode)	INPUT IMPEDANCE
Input 1 - R1	2.49Kohm	11V	0.46xIc	17.5 Kohm
Input 2 - R2	15Kohm	19V	0.27xIc	30Kohm
Differential - R3,4	20Kohm	30V	0.27xIc	30 Kohm

**See chapter 4.1 for calculation of other values**

#### 7.1.4 Activating the loss of tacho protection (velocity mode only)

Activating the loss of tacho protection is done by installing R14 (different value for 65V or 135V amplifiers), R15, and R16 as follows:

$$R14_{(65V)} = \frac{1530}{V_{am}} \quad (\text{Kohm})$$

$$R14_{(135V)} = \frac{2730}{V_{am}} \quad (\text{Kohm})$$

$$R15 = \frac{100 \times V_{am}}{I_p \times R_m} \quad (\text{Kohm})$$

$$R16 \leq 10 \text{ ohm}$$

$V_{am}$  - Armature voltage at maximum application speed.

$I_p$  - Amplifiers' rated peak current limit.

$R_m$  - Total ohmic resistance of motor.

R9 should be calculated and inserted according to the tacho voltage at maximum application velocity ( $V_{tm}$ ):

**For  $V_{tm} > 7.5V$ :**

insert R9 = 301Kohm.

**For  $V_{tm} < 7.5V$ :**

$$R9 = \frac{2250}{V_{tm}} \quad (\text{Kohm})$$

### 7.1.5 Latch mode of the protective functions

Self Restart(D17 removed): The amplifier is inhibited only for the period that the inhibit cause is present.

Latch (D17 - inserted): Failures 4.7.1-5 latch the Inhibit and the diagnostic LED. For restart (after clearing the failure source), reset has to be performed by connecting the reset input to the circuit common.

### 7.1.6 Activating the dynamic contouring of the current limits

If you do not use this feature make sure that R11 and R13 are not installed on the board.

If you want to activate this function refer to appendix B.

## 7.2 Velocity control using tachogenerator feedback

When using tacho feedback, it is recommended to use the single ended input no.2 for the tacho signal and to use the differential input for the reference signal in order to reduce common mode noises.

R2,R3 and R4 are calculated and inserted for two tacho voltage ranges:

#### For $V_{tm} > 7.5V$

$$R3 = R4 = 1.33 \times V_{dm} \quad (\text{Kohm})$$

$V_{dm}$  - maximum reference voltage at the differential input.

$$R2 = 2 \times V_{tm} - 15 \quad (\text{kohm})$$

$V_{tm}$  - Voltage generated by the tacho at maximum velocity.

#### For $V_{tm} < 7.5V$

$$R3 = R4 = 10 \times V_{dm} / V_{tm} \quad (\text{Kohm})$$

$V_{dm}$  - maximum reference voltage at the differential input.

$V_{tm}$  - Voltage generated by the tacho at maximum velocity.

$$R2 = 470 \text{ Ohm}$$

### 7.3 Velocity control using armature voltage feedback

The reference signal should be connected to the differential input and R3,R4 should be calculated and inserted according to:

$$R3 = R4 = 1.33xVdm \quad (\text{Kohm})$$

Vdm - maximum reference voltage at the differential input.

The armature voltage feedback will enter the error amplifier by inserting R8, calculated for the two voltage types as follows:

**For ISP-X/65:**

$$R8_{(65V)} = 1.3xVam \quad (\text{Kohm})$$

Vam - armature voltage at maximum application speed

**For ISP-X/135:**

$$R8_{(135V)} = 0.73xVam \quad (\text{Kohm})$$

Vam - armature voltage at maximum application speed

**IxR compensation**

In order to improve the speed stability in various load conditions, an IxR compensation is required. This is achieved by:

- Connect the Current Feedback Monitor (terminal H-7,R-26a,E-J1/6) to input 1 (terminal H-1,R-32a,E-J1/3).
- Rotate T7 to max. CCW position (minimum IxR compensation).
- Insert R1 as follows:

$$R1 = \frac{3 \times Vam}{Rm \times Ip} \quad (\text{Kohm})$$

Vam - Armature voltage at maximum application speed.

Ip - Amplifiers' rated peak current limit.

Rm - Total ohmic resistance of motor.

## **8. Amplifier adjustment and diagnostics**

### **Important remarks:**

A. If all the previous steps were accomplished you may now turn on the power and continue with the following adjustments. You may omit the step for current mode or velocity mode according to your application.

B. In some applications, especially those where the motor electrical parameters (total inductance and resistance in the armature circuit) are much smaller or larger than normally encountered, the current loop response should be optimized before proceeding with the following steps - See Appendix A.

### **8.1 Balance adjustment**

If the motor is rotating with the command signal at zero voltage, a balance adjustment will be necessary. Turn the balance trimmer (T5) as required until the motor stops. As a rule, have the command signal connected and set to zero when balancing the amplifier. This way, any offset in the command signal will be canceled.

### **8.2 Current limit adjustment**

The amplifiers' current limits can be adjusted without the need for loading. Disconnect motor leads and connect a voltmeter between the Current Command Monitor (terminal H-15,R-18a,E-J1/7) and the circuit common. Apply maximum input voltage to one of the inputs to cause an error at the error amplifier (input gain trimmer should be fully CW). In order to adjust the continuous limit - turn T3 (Ip) fully CCW to disable Ip, then use T2 (Ic) to adjust the continuous limit by monitoring the meter readout. Full CW rotation of T2 will result in rated current limit. After adjusting the continuous limit, turn T3 up to the desired peak level.

The current monitor range is up to 7.5V and its scale depends on the amplifier rated continuous current (Ic) and is given by:

	Ic
Current monitor scale (A/V) :	-----
	3.75

### 8.3 Adjusting the motor speed (velocity mode only)

Adjusting the speed is done by adjusting the input gain trimmer of the tacho feedback:

- Increasing/decreasing the feedback gain will decrease/increase the speed.

It is also possible to increase/decrease the command gain (change the fix resistors of the differential amplifier) in order to increase/decrease the speed.

Best performance is achieved when the feedback gain is as close as possible to its maximum value. Therefore, the final adjustment should yield with Ki of the tacho input trimmer over 0.8.

### 8.4 Adjustment of the IxR compensation

If you do not use this feature, skip this chapter.

After following all the instructions in 7.3, you may improve the speed stability in various load conditions by performing the following procedure:

- a. Run motor at 2/3 of nominal speed.
- b. Apply nominal load.
- c. Increase IxR compensation (CW rotation of gain 1 - trimmer T7) until motor's speed reaches the no load speed.
- d. Notice that a high compensation may result in unstable operation of the amplifier.

Reducing the DC and AC gains of the error amplifier by increasing C1 and R5 is recommended. The final values depend on the type of motor and mechanical load, so optimum results will be achieved by the empirical method.

### 8.5 Response adjustment (velocity mode only)

In most applications optimum response is achieved by adjusting the compensation (COMP) trimmer. Adjustment procedure is as follows:

- Provide the amplifier with a low frequency, bi-directional square wave velocity command (A 0.5Hz, 2.0V waveform is often employed)
- Apply power to the amplifier, and while monitoring the tachometer signal, gradually adjust the COMP trimmer from the CCW toward the CW position. Optimum response (critically-damped) should be achieved at some position before reaching full CW on T4. Fig 8.1 illustrates the types of waveforms observed for various setting o T4.

In some applications, especially those where the load inertia is much smaller or larger than normally encountered, the standard compensation components values of 0.022 $\mu$ F for C1 and 470Kohm for R5 may not allow an optimum setting of the COMP trimmer T4. In fact, the velocity loop may be unstable for any setting of T4.

In these cases different values for C1 and R5 must be chosen. The following procedure can be used to select these values:

- Short circuit C1 with a short jumper wire.
- Replace R5 with a decade resistance box. Initially set the box resistance at 20Kohm.
- Set T4, the COMP trimmer to approximately midrange.
- Input a 0.5Hz, 2V bi-directional square wave velocity command signal to the amplifier.
- Apply power, and while monitoring the tachometer signal, gradually increase the value of the box resistance until optimum response a depicted in Fig 8.1 is achieved.
- Substitute the closest standard value discrete resistor for R6 and remove the decade resistance box.
- Remove the shorting jumper across C1, and again check the response using the squarewave test signal. If near optimum result are obtained, trim the response using the COMP trimmer T4 for the optimum.

- If the previous step does not yield satisfactory results, if unacceptable overshooting has been noted, substitute a larger value than  $0.022\pi F$ ; or, if the response is overdamped substitute a smaller value than  $0.022\pi F$ . Repetition of this procedure should yield an optimum choice for  $C1$ .



Reference input signal

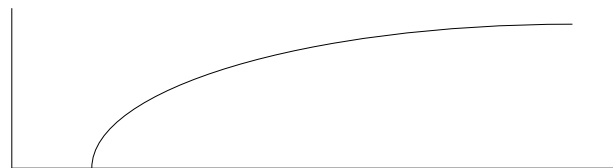

Overdamped: T4 too far CW



Critically damped: T4 optimum

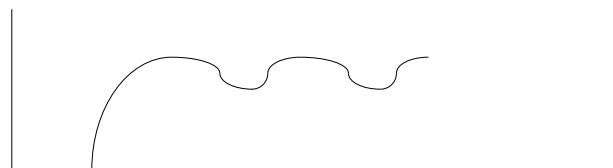

Underdamped: T4 too far CCW

Fig. 8.1

Typical velocity response waveforms

## **9. Tables and Summaries**

### **9.1 Adjusting trimmers**

Six trimmers are installed on the ISP board with the following functions:

- T7 (Gain 1) - CW rotation increases input 1 gain.
- T6 (Gain 2) - CW rotation increases input 2 gain.
- T5 (Balance) - see 8.1.
- T4 (compensation) - See 8.6.
- T3 (Ip) - CW rotation increases peak current limit (see 8.2).
- T2 (Ic) - CW rotation increases continuous current limit (see 8.2)

### **9.2 LED diagnostics**

Four LEDs are installed on the ISP with the following designations: Ic, In, Vs, SO. Under normal operation only Vs should illuminate (Vs indicates the existence of supply voltages). The following table represents the faults indications of the LEDs:

	1	2	3
Ic		X	
In	X		
Vs	X	X	X
SO			X

X - Illuminated LED

1. One or more of: external inhibit, under/over voltage, short circuit, excess temperature, loss of tacho or insufficient load inductance.
2. Continuous current limit.
3. The shunt is "ON".

## Appendix A - Response adjustment - current loop

In most applications it is not necessary to adjust the current loop to achieve the optimum response. When there are extreme electrical parameters in the armature circuit (inductance and resistance) the standard components values of 0.01 $\mu$ F for C2 and 100Kohm for R7 may not yield with the optimum response. The current loop should be optimized as follows:

- Turn the amplifier to a current amplifier by removing C1 and R6.
- Provide the amplifier with a bi-directional square wave current command (100-200Hz, 2.0V waveform is often employed).
- Apply power to the amplifier, and monitor the load current either by a current probe or by the current monitor.

If the current response is not critically damped, use the following procedure

- Short circuit C2 with a short jumper wire.
- Replace R7 with a decade resistance box. Initially set the box resistance at 10Kohm.
- Apply the square wave test signal to the amplifier input.
- Apply power, and while monitoring the load current, gradually increase the value of the box resistance until optimum response as depicted in Fig A-1 is achieved.
- Substitute the closest standard value discrete resistor for R7 and remove the decade resistance box.
- Remove the shorting jumper across C2, and again check the response using the square wave test signal.
- If the previous step does not yield satisfactory results, if unacceptable overshooting has been noted, substitute a larger value than 0.01  $\mu$ F; or, if the response is overdamped, substitute smaller value than 0.01  $\mu$ F. Repetition of this procedure should yield an optimum choice for C2.

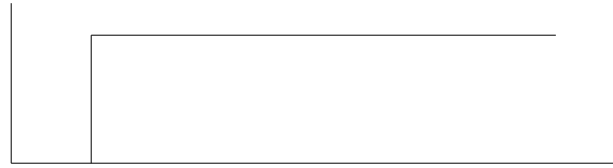

Reference input signal

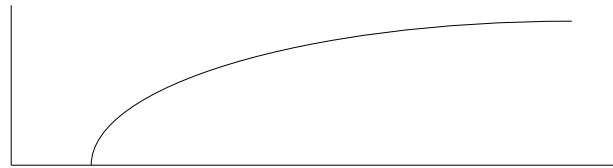

C2 too large / R7 too small



Critically damped

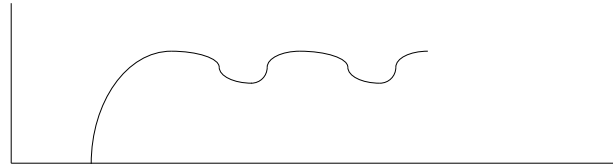

C2 too small / R7 too large

Fig. A-1

Typical current response waveforms

## Appendix B - Current limits contour adjustment

The amplifier can be configured to have either continuous current limit or peak current limit or both which depend on motor velocity feedback. This function is enabled by calculating and inserting R11, R13.

The continuous current limit is speed dependent when R11 is inserted.

The peak current limit is speed dependent when R13 is inserted.

The general shape of the operating envelope is given in fig. B-1

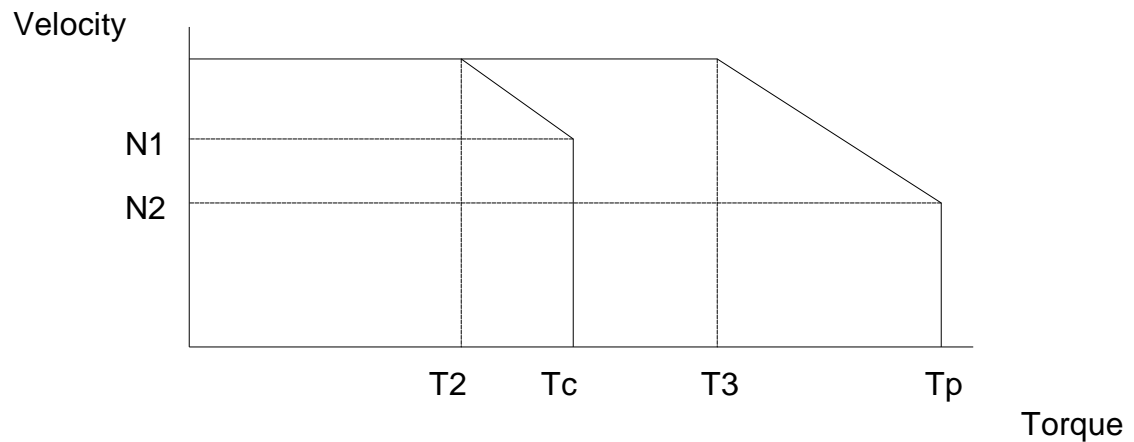

Tc - Max continuous torque up to velocity N1

T2 - Continuous torque at max velocity (Nmax).

Tp - Max peak torque up to velocity N2.

T3 - Peak torque at maximum velocity.

Fig. B-1: Current limits contour

The user should derive the relations  $r1=N1/Nmax$ ,  $r2=T2/Tc$ ,  $s1=N2/Nmax$  and  $s2=T3/Tp$  from the motor data sheet.

R11 and R10 (for continuous limit) and/or R13/R12 (for peak limit) should be installed according to the following relations:

Continuous current limit contouring:

$$R_{11} = 18.3 \frac{1 - r_1}{1 - r_2} \quad (\text{Kohm})$$

$$R_{10} = 36.6 \frac{R_{11}}{R_{11} + 20r_1} \quad (\text{Kohm})$$

Peak current limit contouring:

$$R_{13} = 18.3 \frac{1 - s_1}{1 - s_2} \quad (\text{Kohm})$$

$$R_{12} = 36.6 \frac{R_{13}}{R_{13} + 20s_1} \quad (\text{Kohm})$$

#### **Dynamic contouring with armature voltage feedback**

- IxR compensation must be activated as in 7.3
- Connect the Back EMF (terminal H-16,R-18c,E-J2/7) to input 2 (terminal H-5,R-28a,E-J2/8).
- Remove R31.
- Insert R2 = 470 Ohm
- Insert R9 = 301 Kohm
- Calculate and insert R14 as in 7.1.4.

# **DIMENSIONAL DRAWINGS**

---

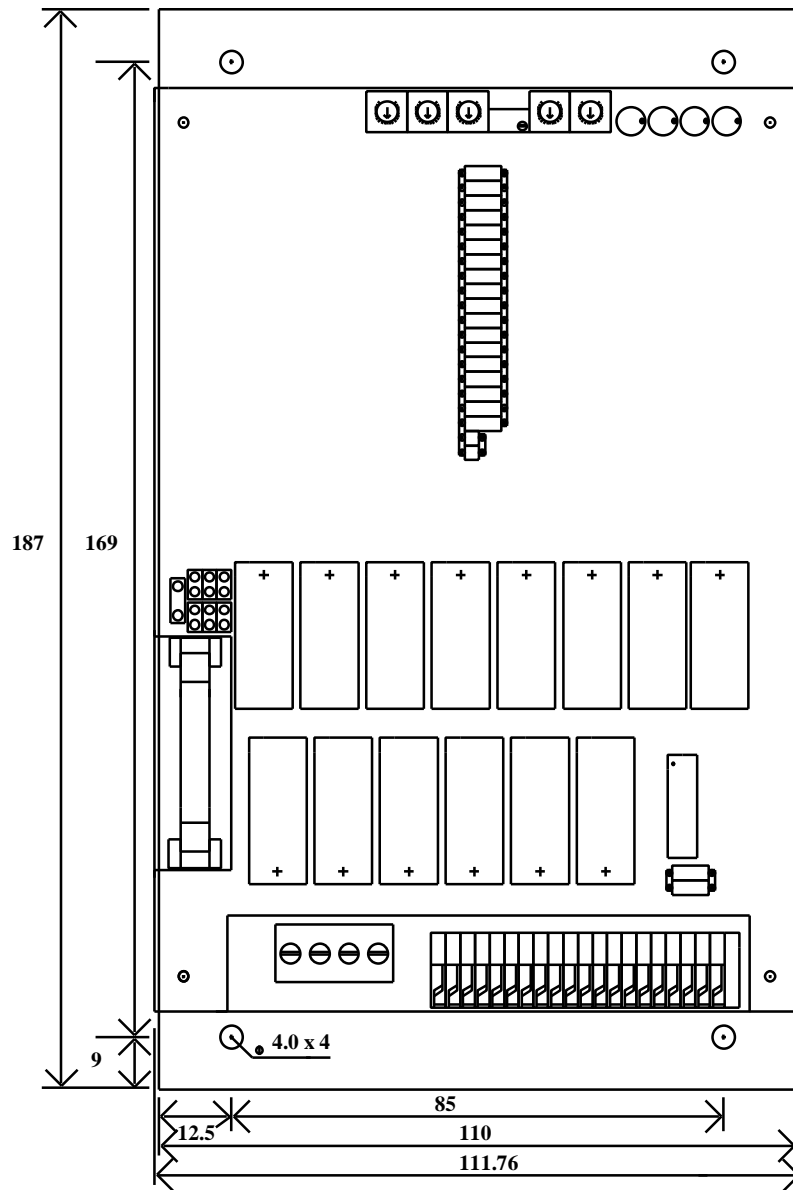

**SP1 - TOP VIEW**

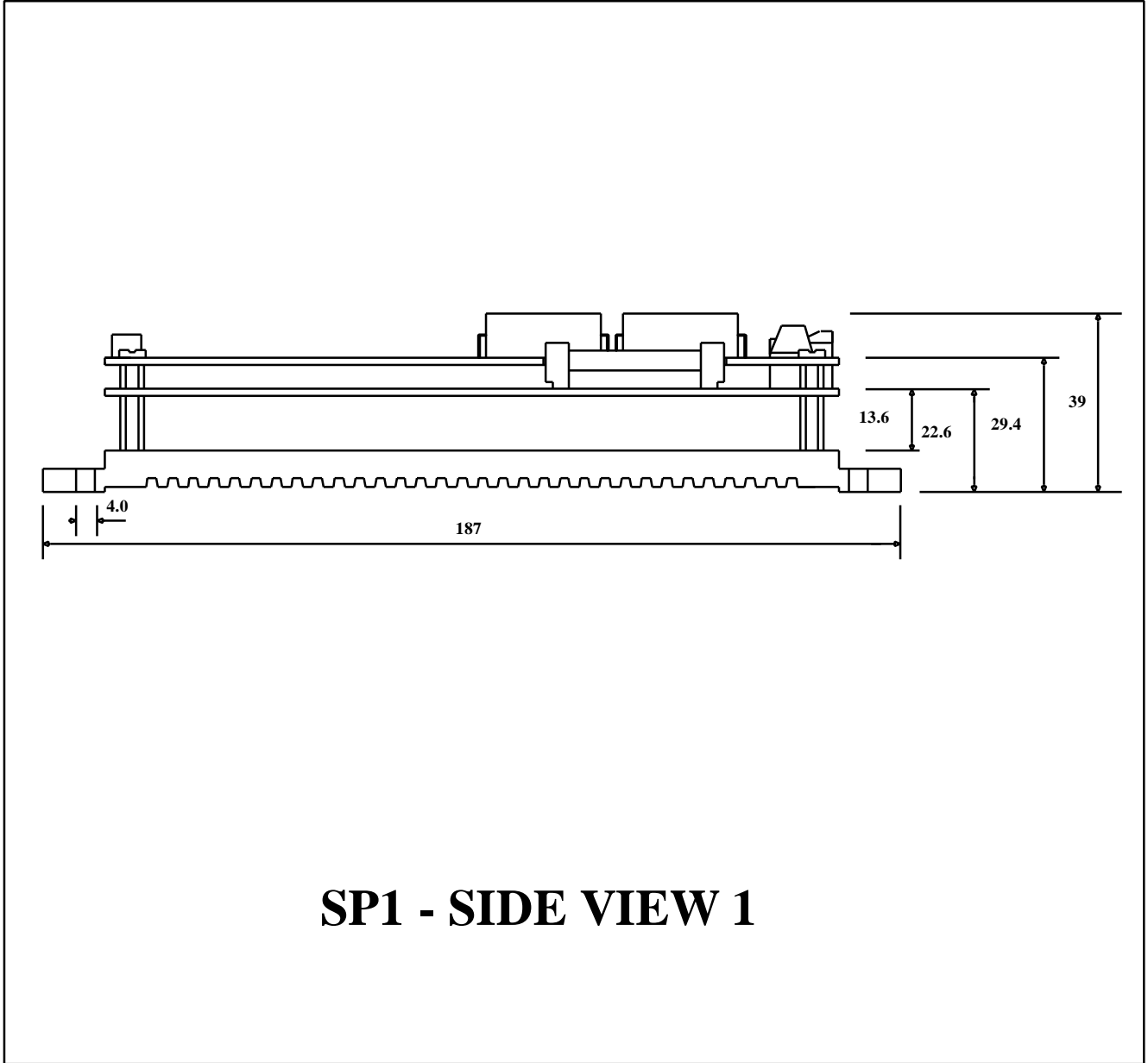

**SP1 - SIDE VIEW 1**

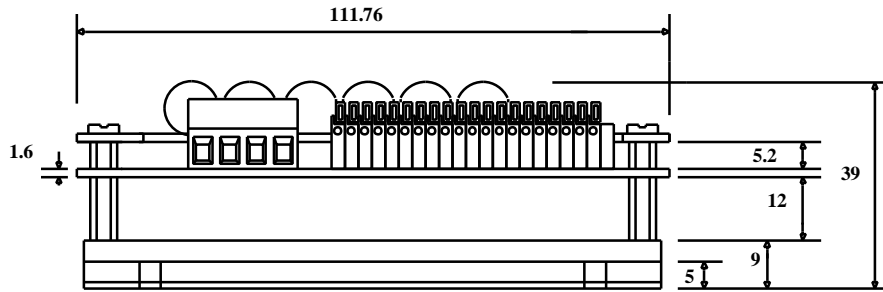

**SP1 - SIDE VIEW 2**

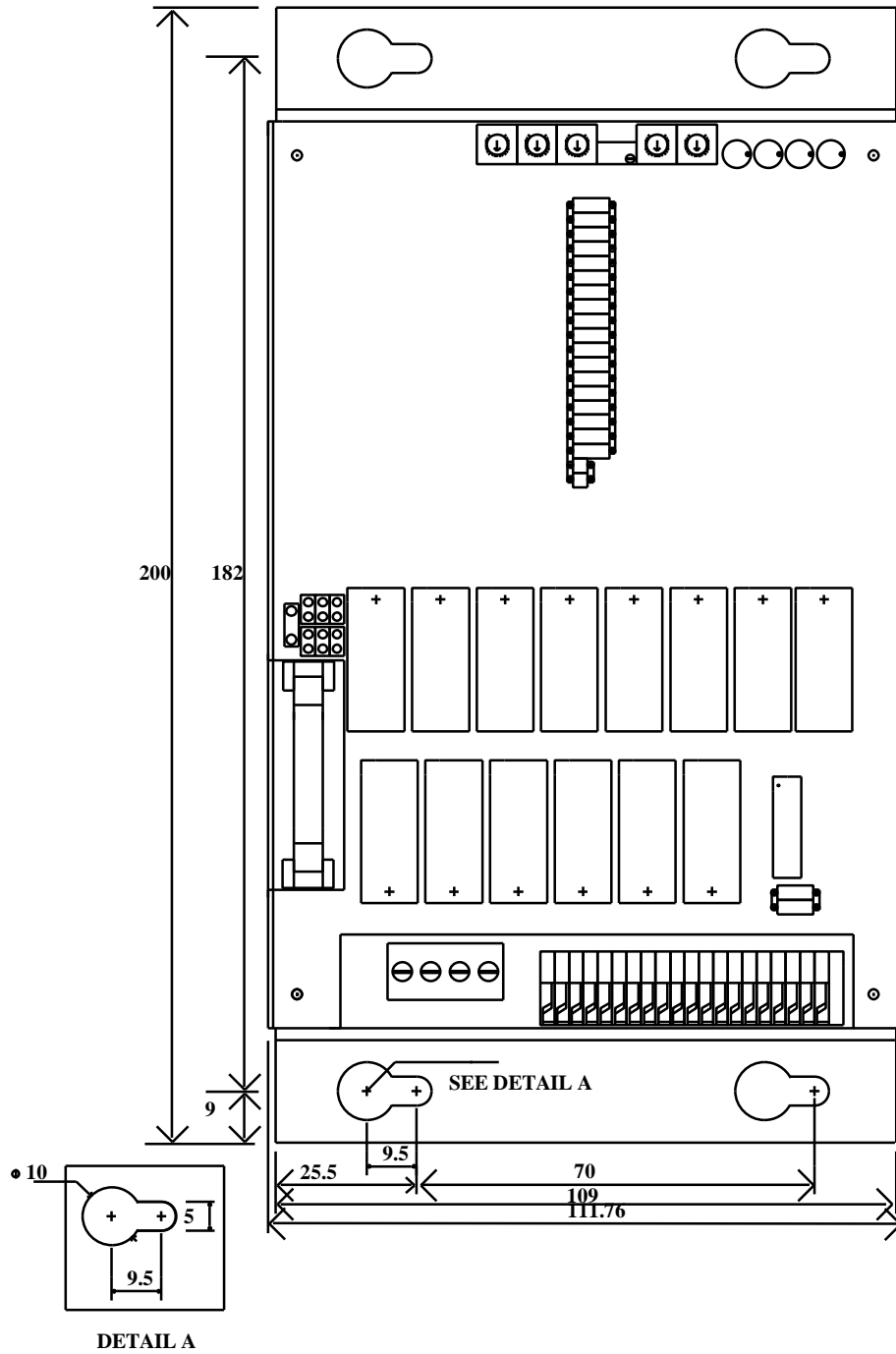

**SP2 - TOP VIEW**

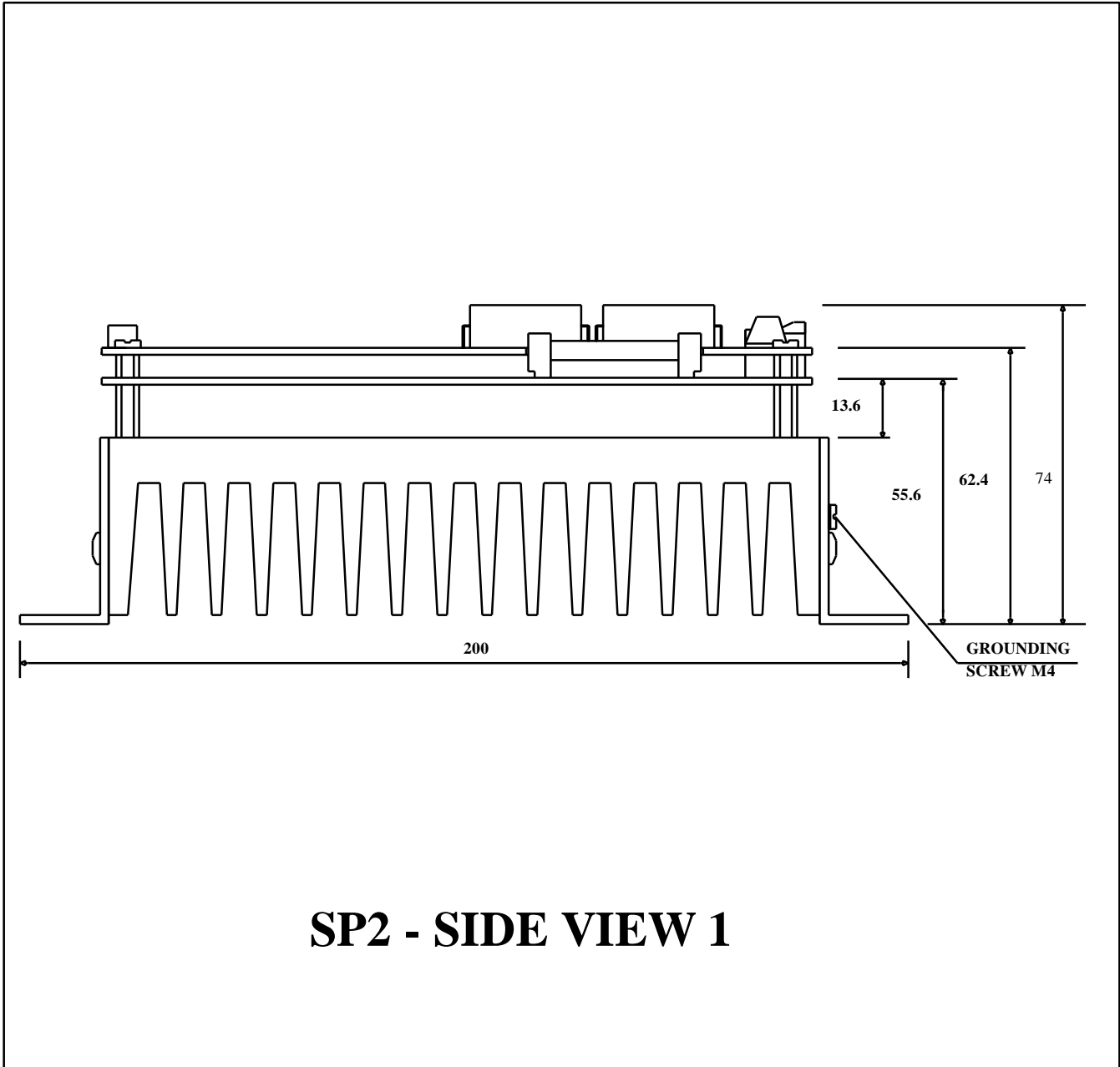

**SP2 - SIDE VIEW 1**

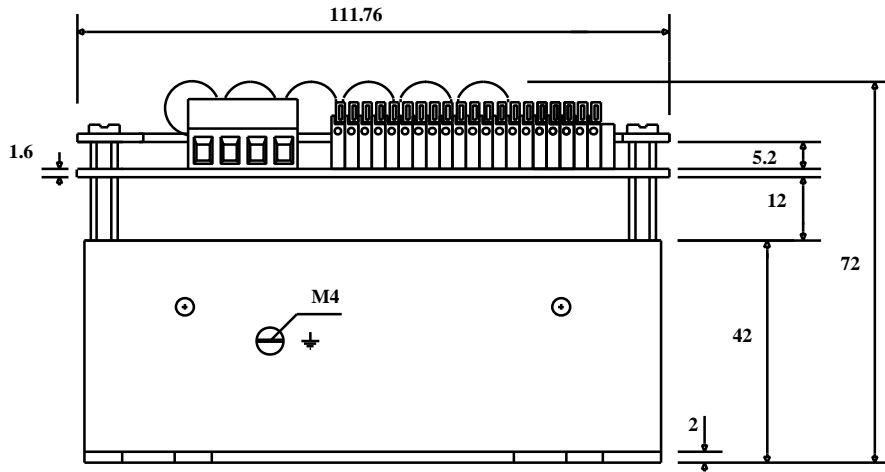

**SP2 - SIDE VIEW 2**

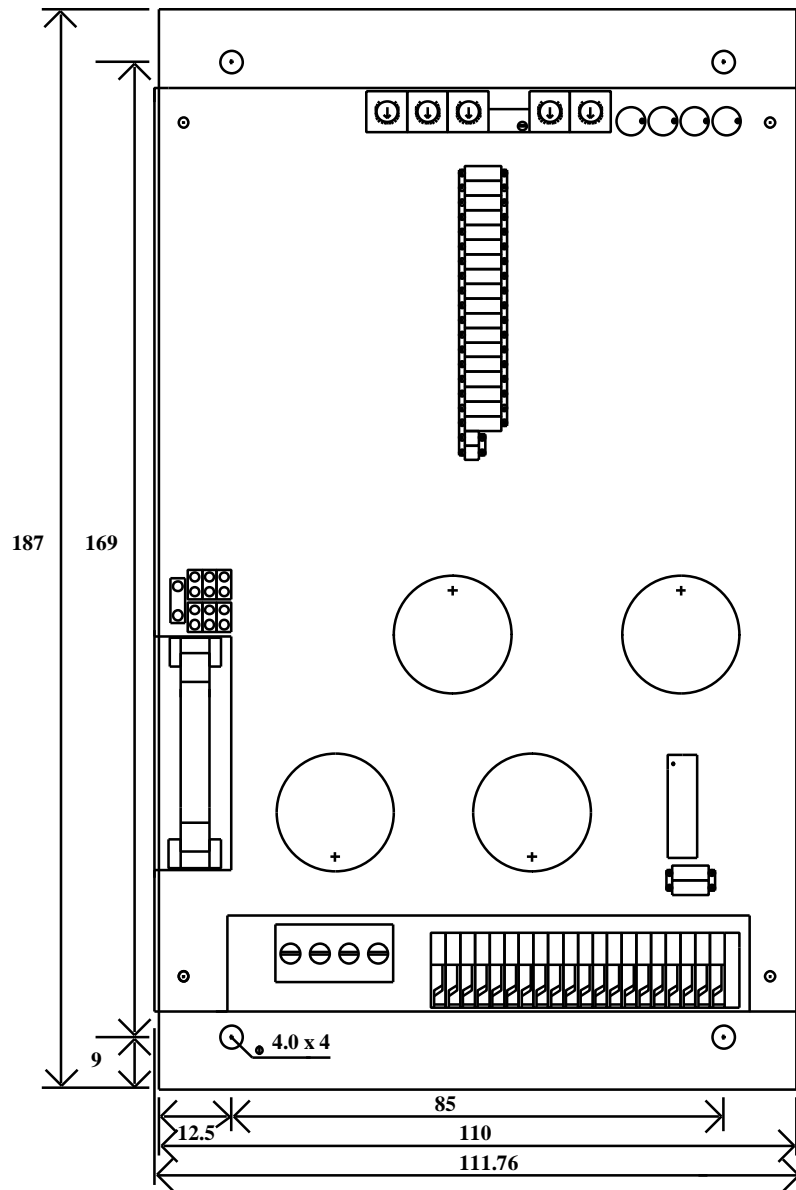

**SP3 - TOP VIEW**

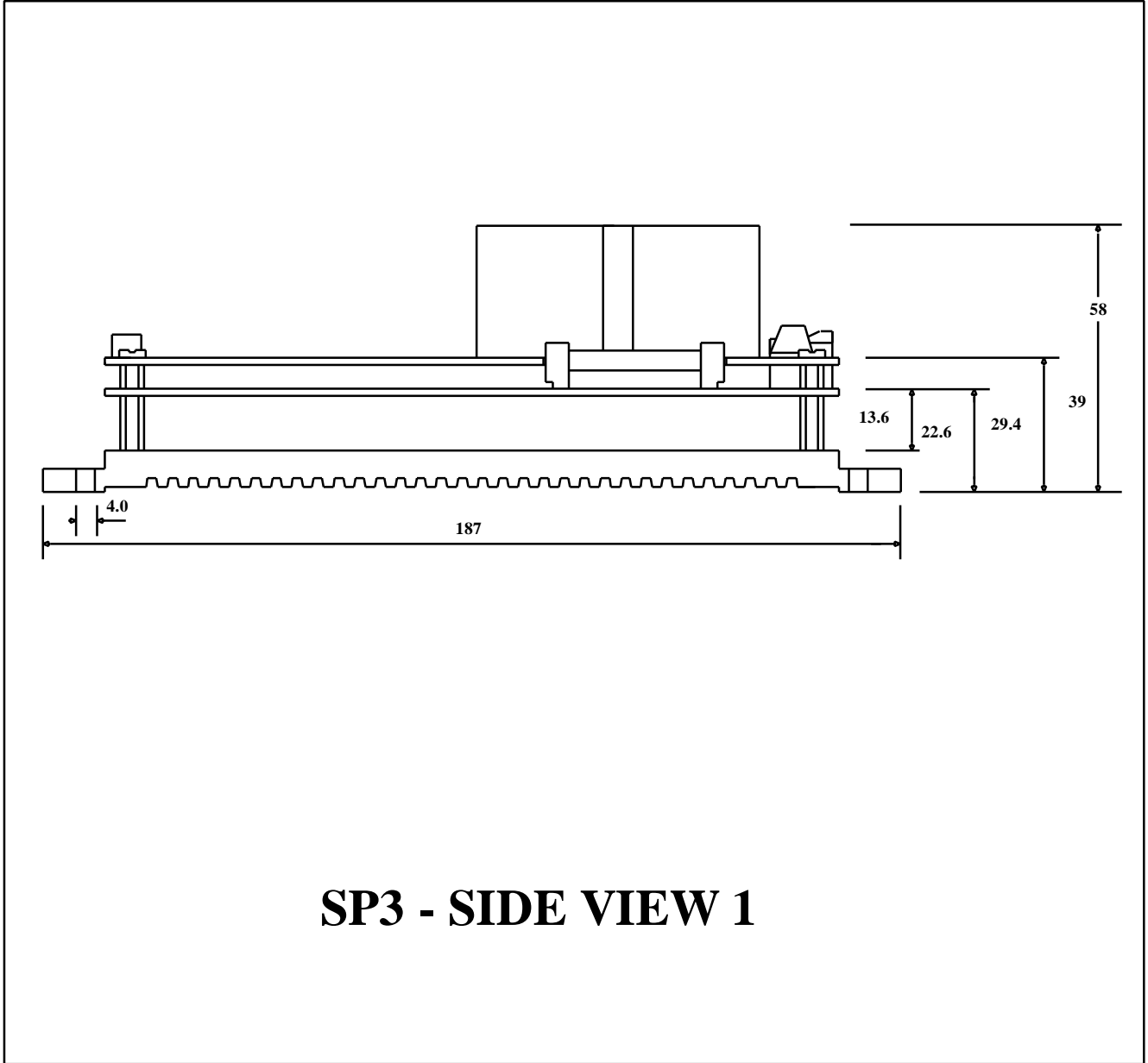

**SP3 - SIDE VIEW 1**

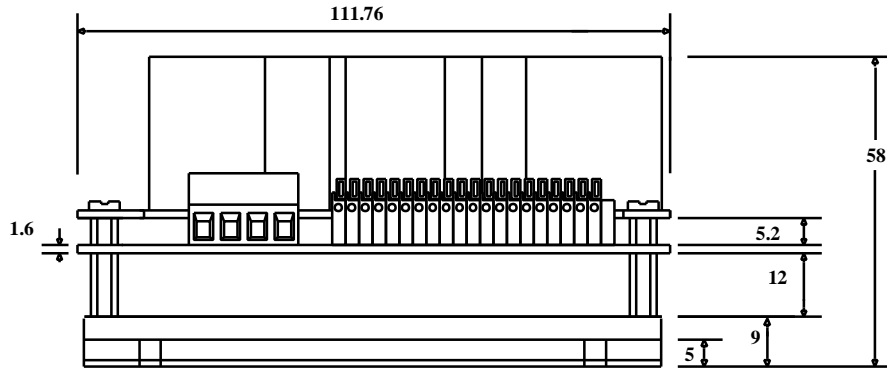

**SP3 - SIDE VIEW 2**

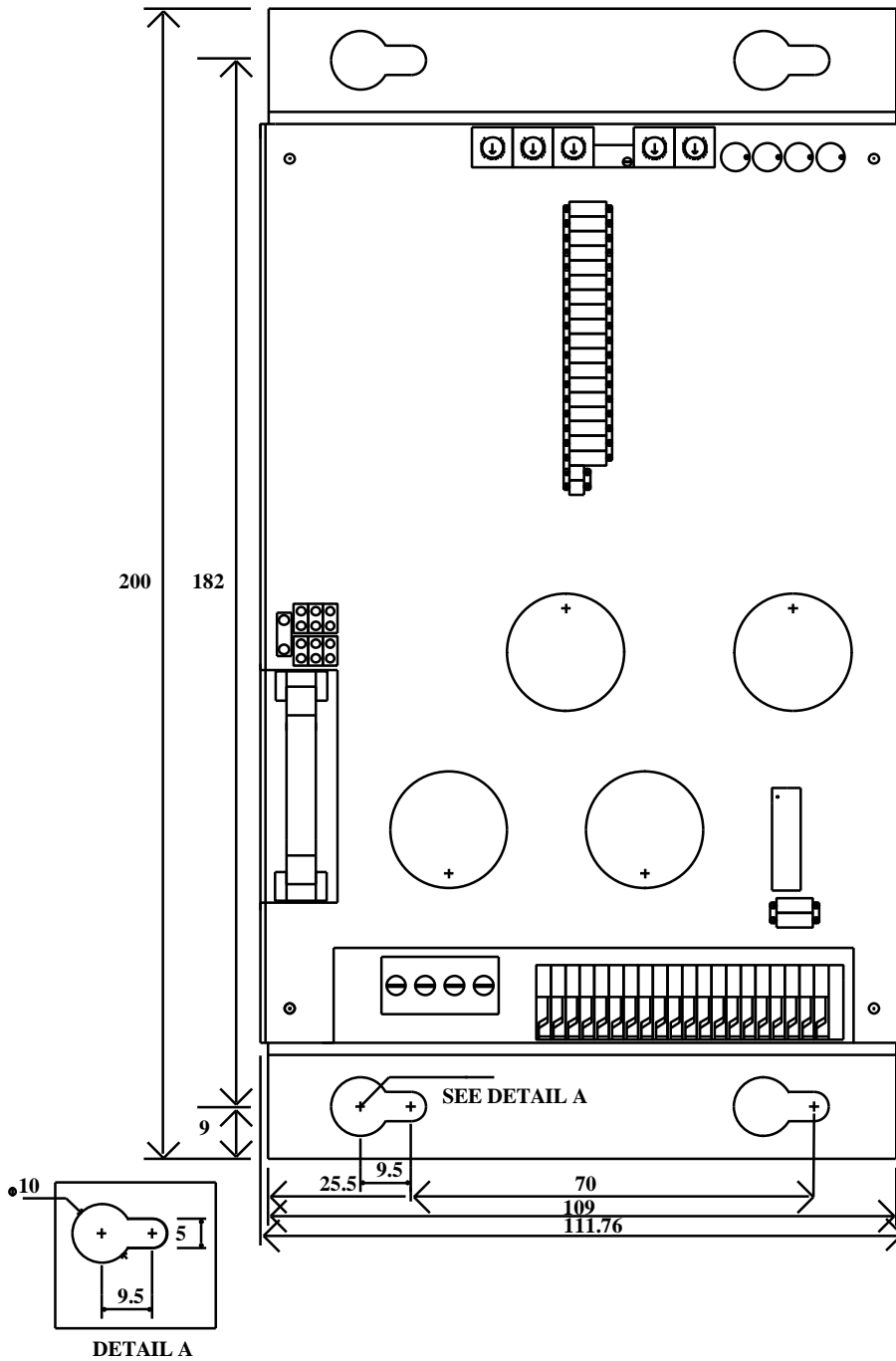

**SP4 - TOP VIEW**

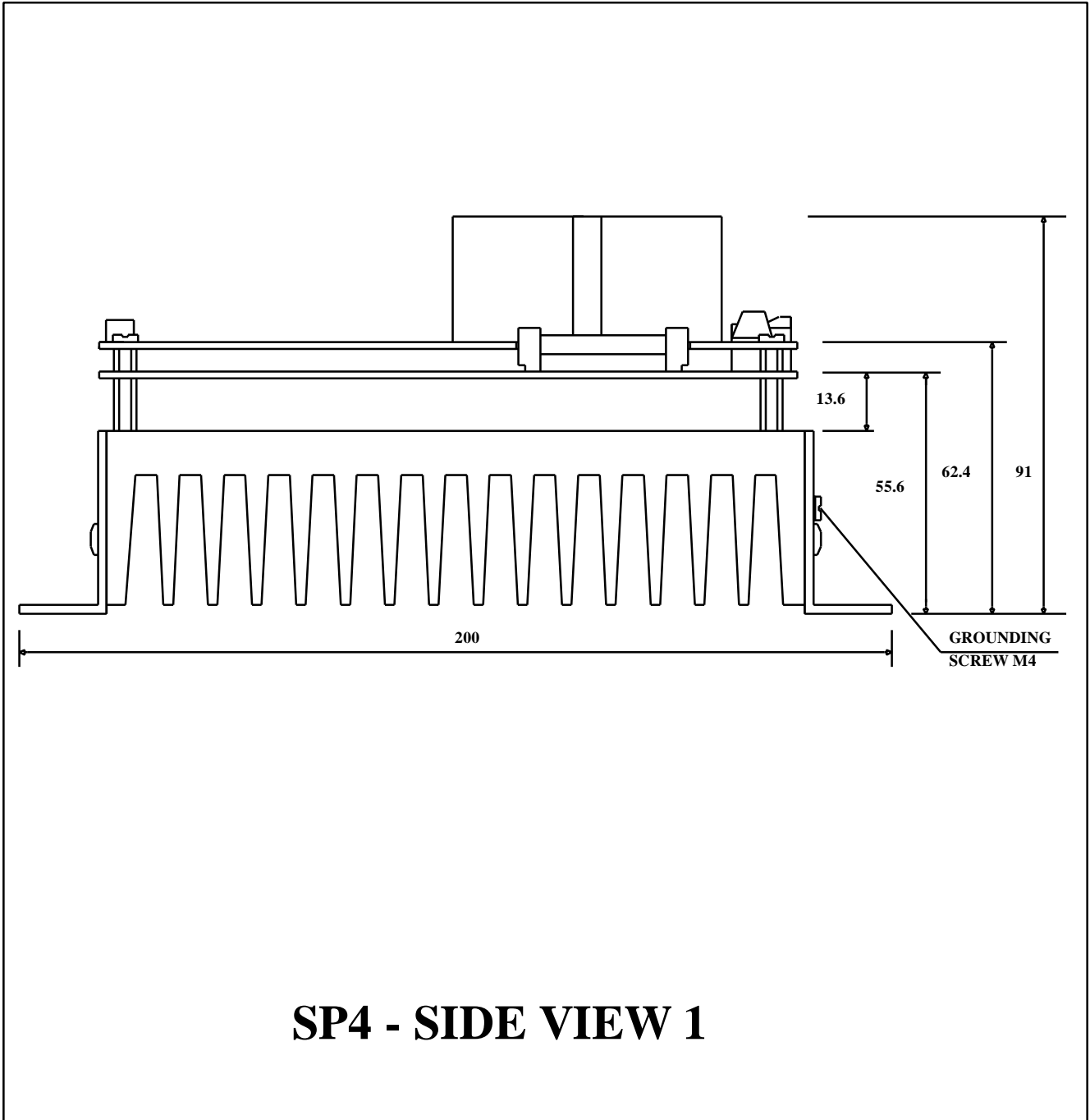



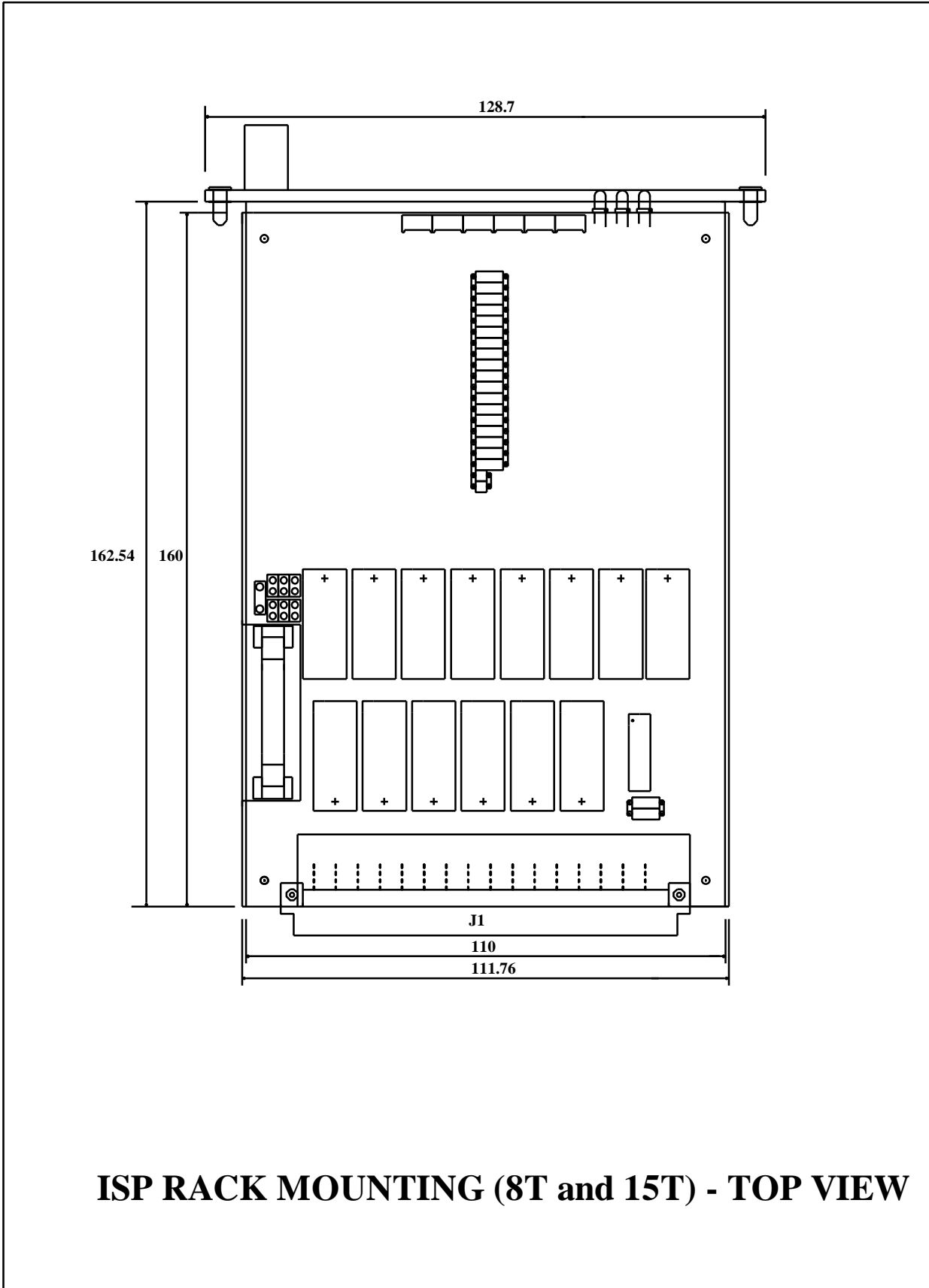

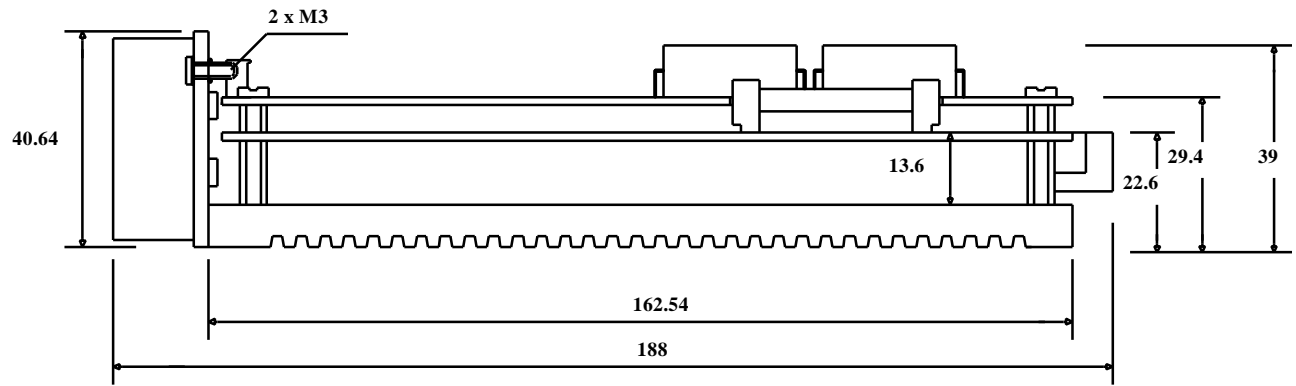

**ISP RACK MOUNTING (3U/8T) - SIDE VIEW 1**

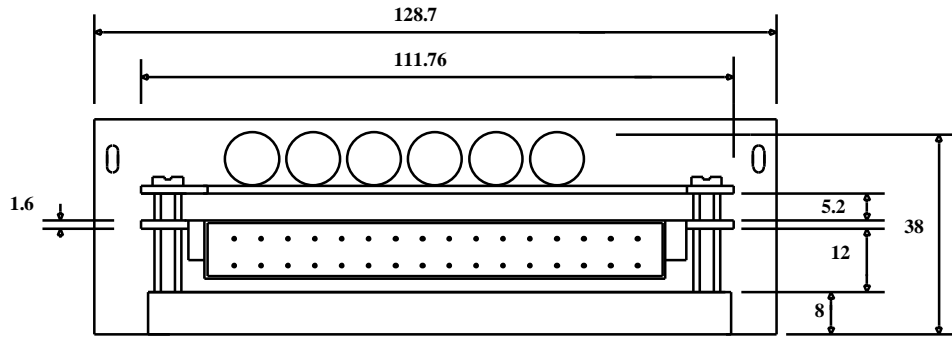

**ISP RACK MOUNTING (3U/8T) - SIDE VIEW 2**

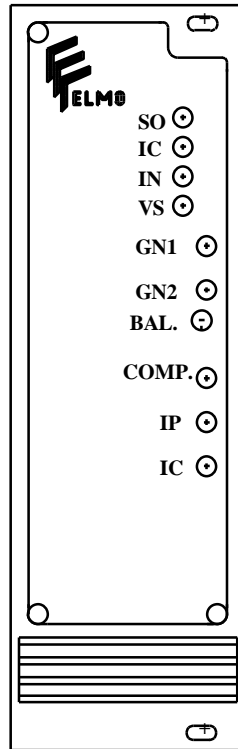

# FRONT PANEL FOR ISP 3U/8T

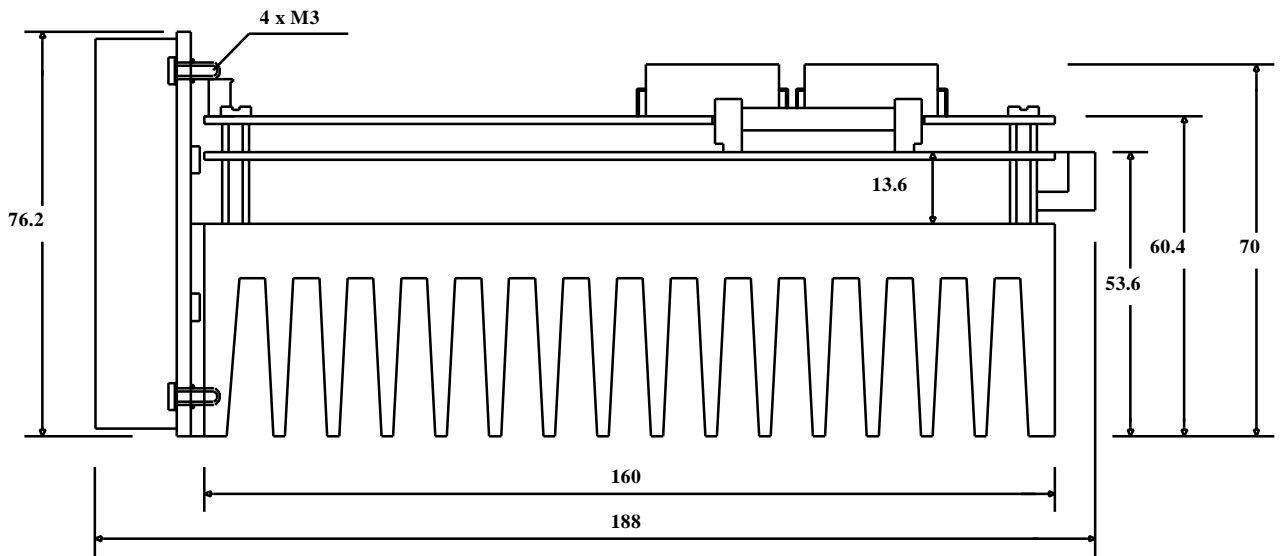

**ISP RACK MOUNTING (3U/15T) -SIDE VIEW 1**

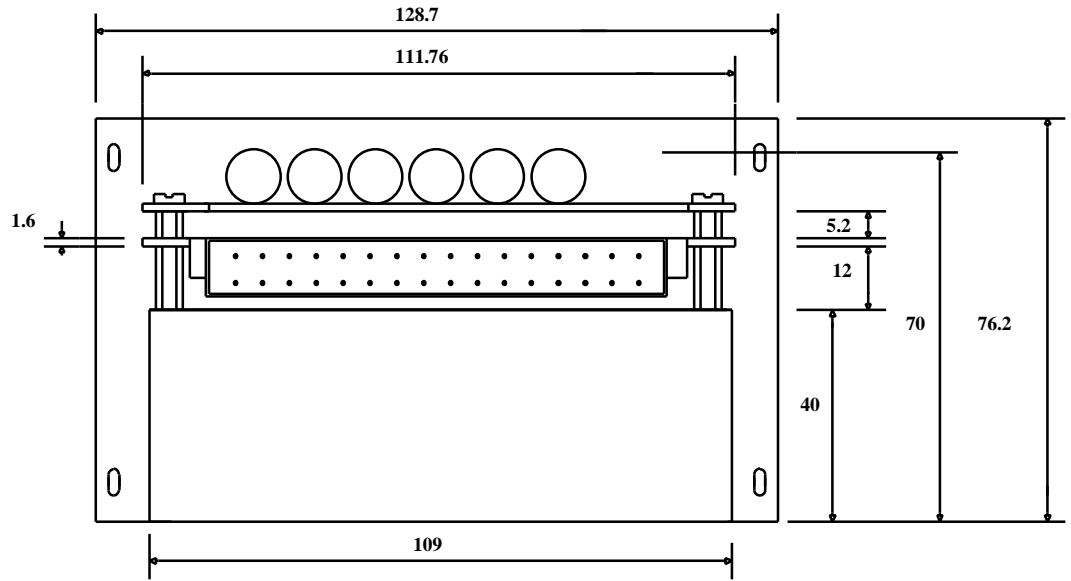

**ISP RACK MOUNTING (3U/15T) - SIDE VIEW 2**

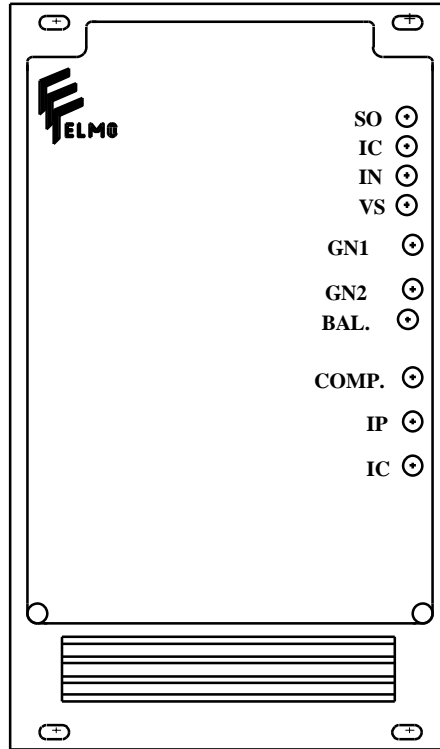

## FRONT PANEL FOR ISP 3U/15T

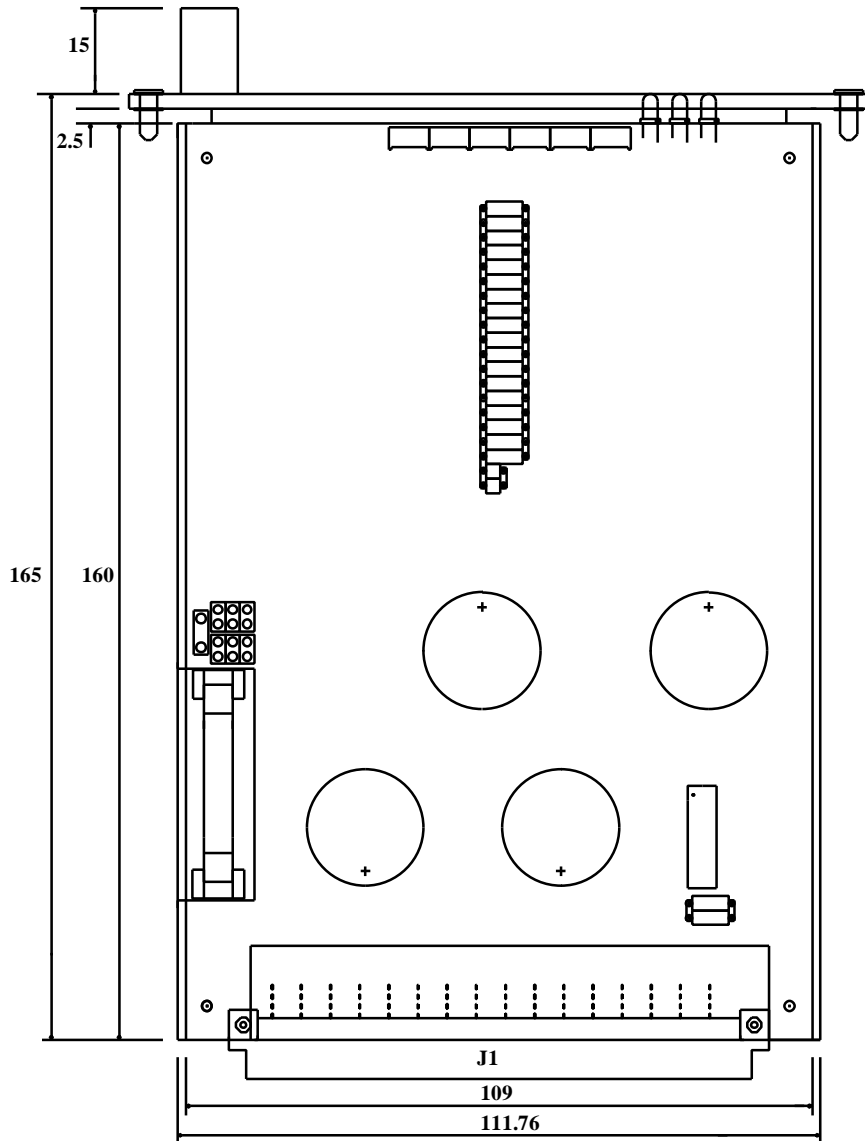

**ISP RACK MOUNTING (3U/12T and 3U/19T) - TOP VIEW**

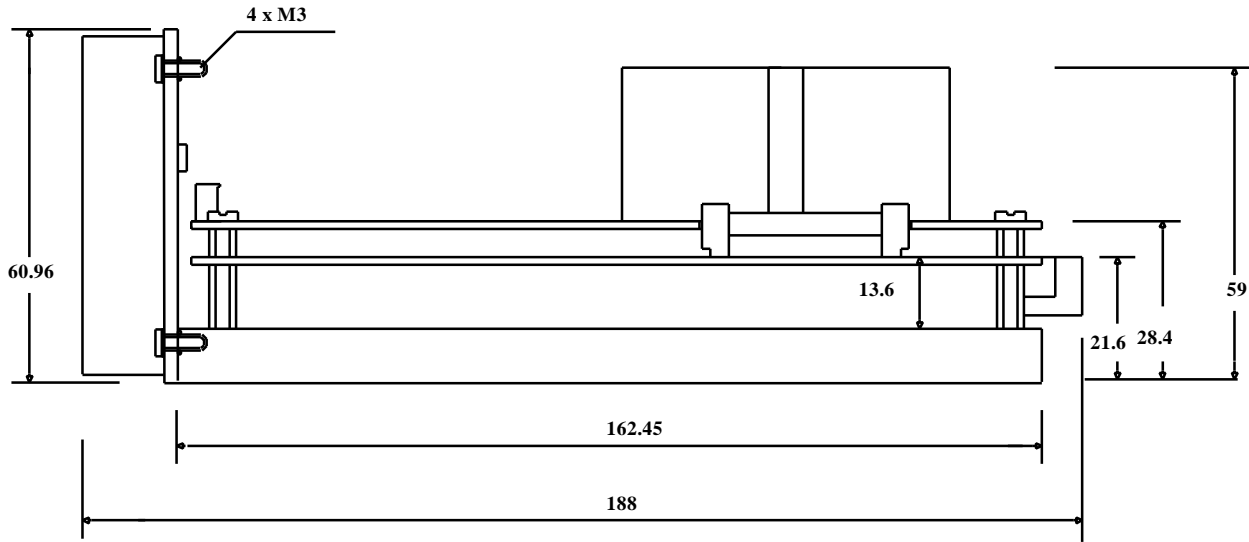

**ISP RACK MOUNTING (3U/12T) -SIDE VIEW 1**

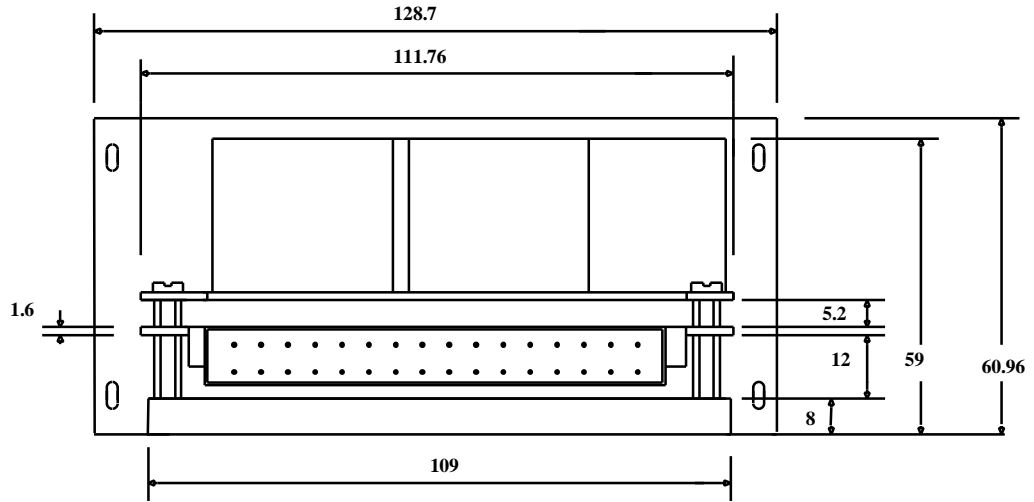

**ISP RACK MOUNTING ( 3U/12T) - SIDE VIEW 2**

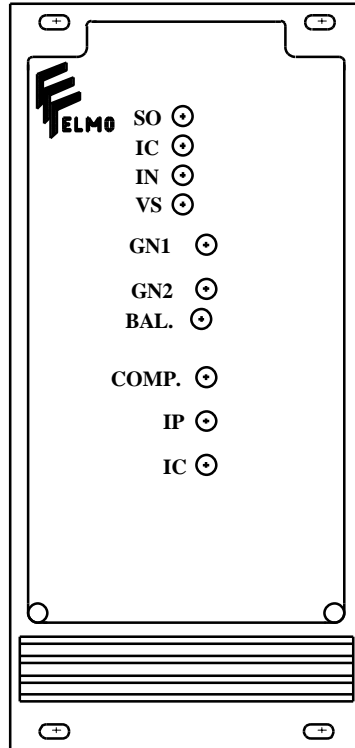

## FRONT PANEL FOR ISP 3U/12T

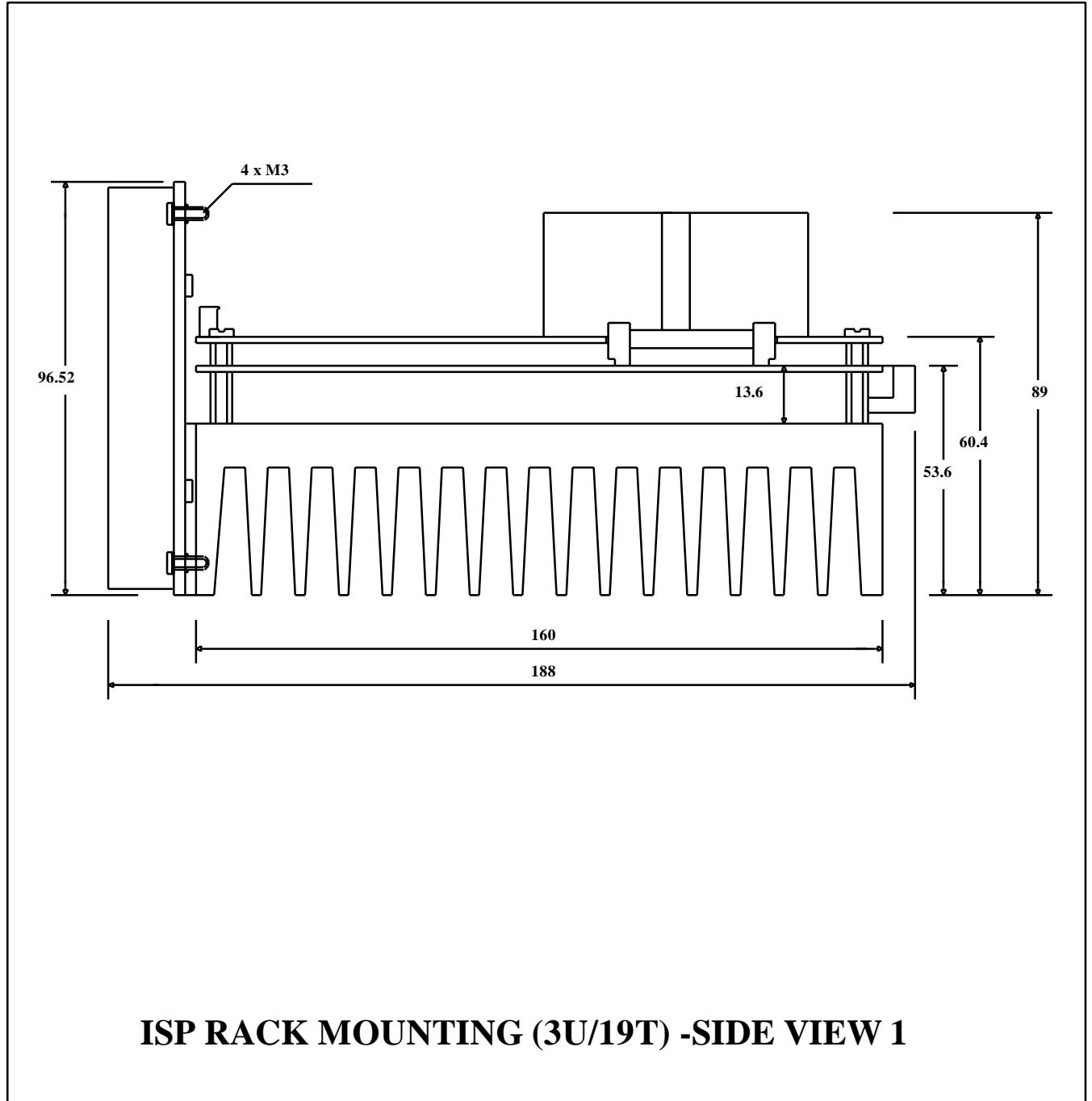

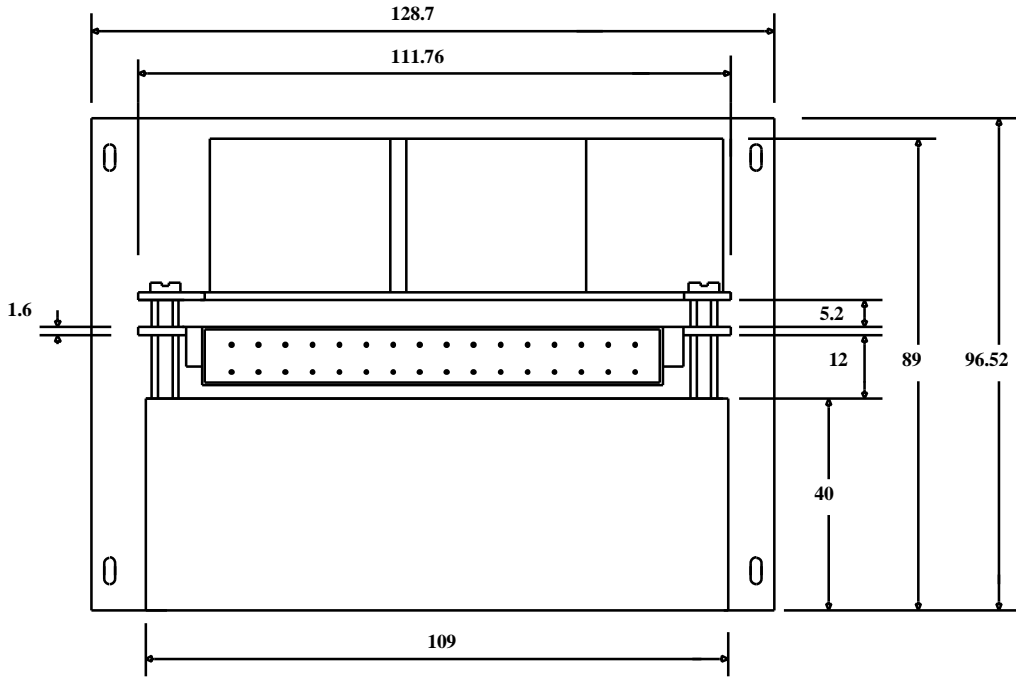

**ISP RACK MOUNTING ( 3U/19T) - SIDE VIEW 2**

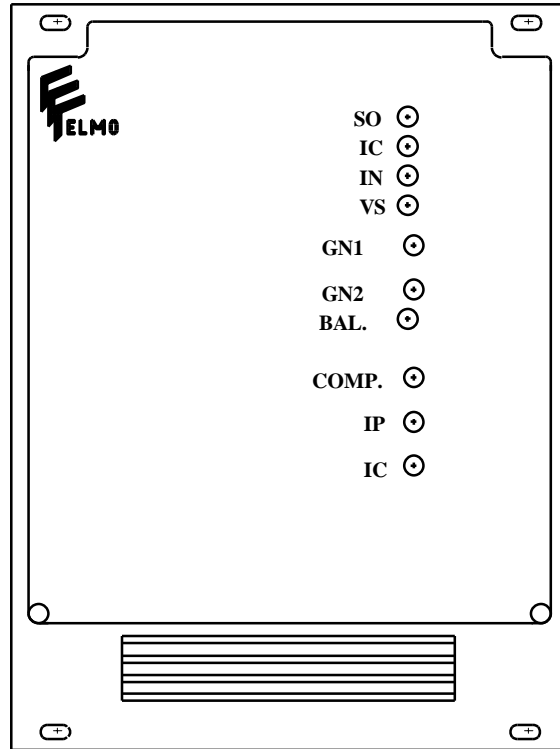

## FRONT PANEL FOR ISP 3U/19T

# ENCLOSURE MECHANICAL OUTLINE

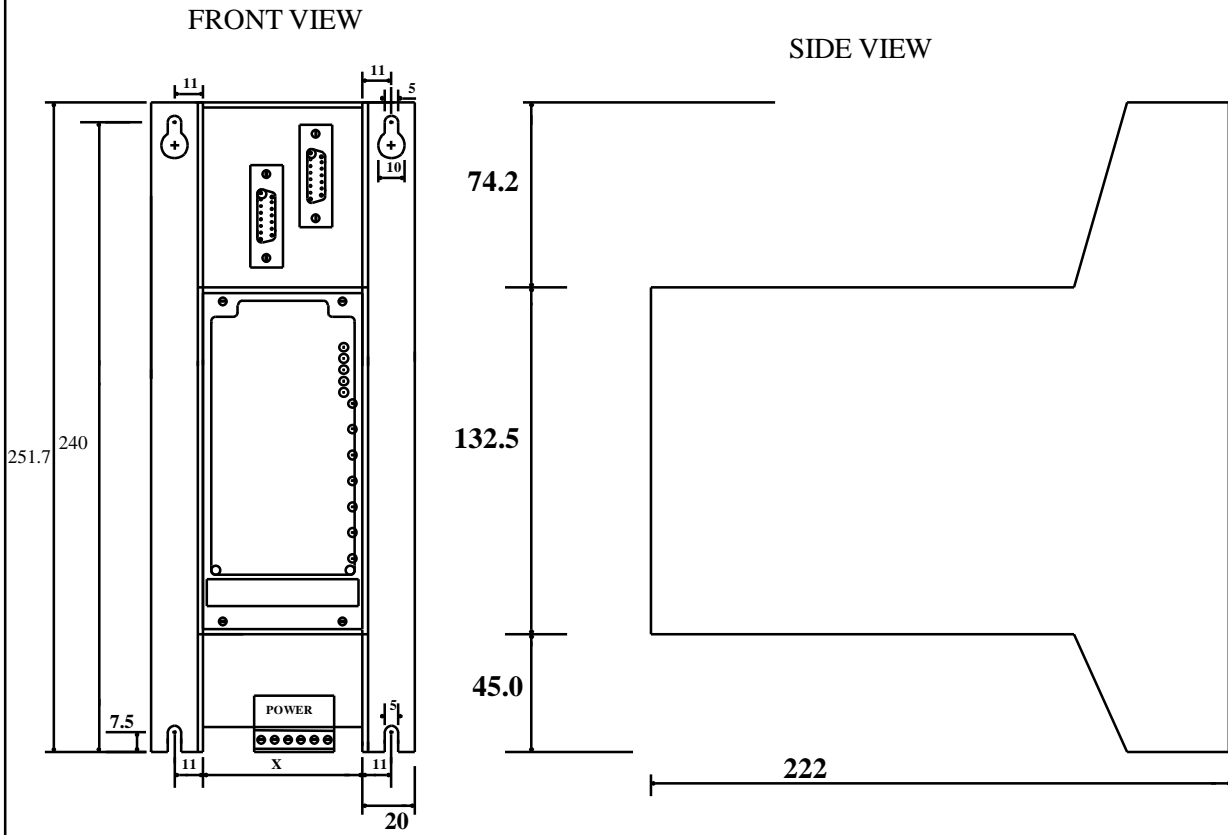

### Standard Sizes

	12T	16T	20T	24T	36T
X	62.0	82.3	102.7	123.0	184.0

For non-standard sizes:  
 $X = 5.08 \times n + 1\text{mm}$

NOTE:

ALL DIMENSIONS ARE IN mm.

**List of ELMO Service Centers**

**ISRAEL**

Elmo Motion Control LTD  
34 Segula ST.  
Petah-Tikva 49103  
Tel: (03)934-5059  
Fax: (03)934-5126

**EUROPE**

Elmo Motion Control  
7 Stanserstrasse  
CH-6362 Stansstad  
Switzerland  
Tel: (041)610775  
Fax: (041)610778

**U.S.A**

Elmo Motion Control INC.  
1200 Woodruff Road,  
Suite C-22,  
Greenville, SC 29607-5731  
Tel: (803) 288-9316  
Fax: (803) 288-9318